

Date of publication xxxx 00, 0000, date of current version xxxx 00, 0000.

Digital Object Identifier 10.1109/ACCESS.2017.Doi Number

Adaptive 2×2 MIMO employed Wavelet-OFDM-Radio over Fibre Transmission

Vishal Sharma¹, Sergey Sergeev² and Jaswinder Kaur³

^{1,2} Aston Institute of Photonic Technology (AiPT), Aston University, Birmingham, UK

³ Research Scholar, IKG Punjab Technical University, Punjab, INDIA

Corresponding author: Vishal Sharma (e-mail: v.vishal@aston.ac.uk).

This work is carried out in Aston Institute of Photonic Technologies, Aston University, Birmingham, UK and is supported by European Union sponsored H2020-MSCA-IF-EF-ST project

ABSTRACT Due to high peak-to-average-power ratio (PAPR) and low spectral-efficiency, the conventional Fast Fourier Transform based orthogonal frequency division multiplexing (OFDM) is losing its place to the other multicarrier modulation schemes. Alternatively, the wavelet treated multiple-input multiple-output (MIMO)-OFDM is gaining its popularity in realization of futuristic 5G networks due to proffering high spectral-efficiency, low-cost and low phase-noise. Subsequently, this work demonstrates a RF transmission system in S-band employing 2×2 MIMO-OFDM using orthogonal- and biorthogonal-wavelets with diverse phase shift keying modulation (PSK) schemes. Among the available MIMO configurations, the authors implement spatial diversity as it promises good reliability in noisy links [11]. However, the distribution of Wavelet-OFDM (W-OFDM) signals over a radio over fibre (RoF) link is critically affected by the optical sub-system non-linearity. So, the simplest 2×2 Alamouti's space-time block code (STBC) is implemented in this work to overcome this non-linearity and to realize a less-complex detection. The work is further extended to realize an adaptive MIMO-RoF system employing W-OFDM scheme to adjust itself to a suitable available phase shift keying strategy as per the link-situation to retain an optimal balance of link-quality and spectral-efficiency.

INDEX TERMS Link-adaptation, MIMO, OFDM, Radio over fibre, Wavelet

I. INTRODUCTION

Recently, an unprecedented demand for a reliable high-speed wireless access is being observed. The facilitation of traditional wireless links to meet this need by using micro- and pico-cell architecture incurs enormous cost for their deployment. So, a versatile front-haul architecture based cost-effective solution of RF transmission over fibre can be utilized to provide high-speed wireless access in indoor as well as outdoor applications by merging the benefits of enormous fibre-bandwidth and high wireless link-mobility [1-2]. Moreover, due to their centralized architecture, it is easier to implement the advanced signal processing methods, for instance, higher order modulation, multi-carrier modulation and MIMO techniques to improve the wireless access in terms of data rate and reliability [3].

However, the frequency selective fading imposes a critical threat for establishing high-bit-rate wireless links by inducing inter-symbol interference (ISI) [4-6]. Most explored and leading multi-carrier technique, which is deployed to alleviate the effect of frequency-selective

fading in broadband wireless technology, is orthogonal frequency division multiplexing (OFDM). The features such as orthogonal subcarrier channels together with simplified carrier- and symbol-synchronizations make the conventional fast fourier transform (FFT) based OFDM an attractive choice for countering the effect of multi-path fading [7-8]. However, the drawbacks such as high side-lobes, high peak-to-average power ratio (PAPR) and lower spectral-efficiency make us to look for alternative options in multi-carrier modulation. Undoubtedly, the problem of high side-lobes can be solved to a great extent if the synthesis filters with small side-lobes are used [5] but is unable to provide the required spectral-efficiency for realization of 5G applications.

On the other side, the implementation of wavelet filter-banks with OFDM produces small side-lobes along with low PAPR and avoids bandwidth wastage due to cyclic-prefix (CP) extension of the traditional OFDM. Due to superior side-lobe suppression by wavelet filter-banks, Wavelet-OFDM (W-OFDM) offers better performance in

contrast to FFT-OFDM [5-6]. In a W-OFDM system, the process of inverse discrete wavelet transform (IDWT) and discrete wavelet transform (DWT) are executed instead of inverse-FFT (IFFT) and FFT. The DWT corresponds to a two-channel analysis filter-bank while the IDWT corresponds to two-channel synthesis filter-bank. The two-channel filter-bank usually comprises of low-pass and high-pass filters that split the input signal into different frequency bands. The low-pass filter (LPF) processes the approximation-coefficients while high-pass filter (HPF) processes the detail-coefficients. Usually, these filters are represented by various wavelets families which are categorized as orthogonal- and biorthogonal-wavelets. The orthogonal-wavelets i.e. Daubechies (db), Symlet (sym), Coiflet (coif) and Dmey deal with the filter-coefficients of ' N^{th} ' order to characterize its family-members. Alternatively, the biorthogonal-wavelets i.e. BiorSplines (bior) and ReverseBior (rbio) use filters of different orders i.e. ' N_a ' and ' N_s ' for analysis and synthesis respectively. The filter-banks comprising of biorthogonal-wavelets are more flexible and can be easily designed in terms of wavelet properties like vanishing-moments, size-of-support and symmetry [9-10]. The vanishing-moment articulates about a function's decay towards the infinity while the size-of-support describes the filter-length. Higher the order of vanishing-moment, longer the filter-size is required. Moreover, wavelets of compact size-of-support along with symmetric-nature are highly desirable for the communication industry [10]. Alternatively, Daubechies provides the minimum size-of-support i.e. two times the number of vanishing-moments but are non-symmetric in nature. While the other orthogonal-wavelets have better symmetry but with longer vanishing-moments. So, a comprehensive investigation of diverse wavelets is highly desirable to implement a suitable wavelet with OFDM for realizing a spectral-efficient radio over fibre system.

Basically, W-OFDM uses orthogonal wavelet-carriers at different scales (i) and time-position (j) functions in preference to the time-windowed complex exponentials of the traditional OFDM. These functions are created by applying translation- and dilation- processes to a distinct-function called mother-wavelet i.e. $\Psi_{i,j}(t)$. The IDWT modulator accepts the data-symbols as a sequence of wavelet- and approximation-coefficients. If X_j^i represents DWT-coefficients at different scale- and time-variables, then IDWT of X_j^i is computed [6, 9] as

$$x(t) = \sum_{i \in I} \sum_j X_j^i \Psi_{i,j}(t) \quad (1)$$

The orthogonal wavelet-subcarriers are generated for a wavelet family as

$$\langle \Psi_{i,j}(t), \Psi_{k,l}(t) \rangle = \begin{cases} 1, & \text{if } i = k, j = l \\ 0, & \text{otherwise} \end{cases} \quad (2)$$

The DWT of $x(t)$ can be computed at the receiving end as

$$X_j^i = \int x(t) 2^{-i/2} \Psi(2^{-i}t - j) dt \quad (3)$$

Additionally, the natural occurrence of multi-path mechanism in a wireless channel can be utilized to improve the performance by deploying multiple antennas at the transmitter and/or receiver to realize a MIMO configured system. Among the three main MIMO configurations i.e. Spatial Diversity (SD), Spatial Multiplexing (SM) and beam diversity; SD offers good reliability in a noisy-channel and improves the signal-coverage by using Alamouti's space-time block codes (STBC) [11]. It is basically a two-branch transmit diversity technique, used to transmit the two-signals at a time via two-antennas within two time-intervals with the optional receiver diversity, i.e., two symbols are transmitted simultaneously but with the probability of re-transmission during the second time-interval. Unlike spatial-multiplexing, the spatial-diversity provides reliable transmission-links with minimal multipath-fading by transmitting the same information several times for successful recovery of at least one copy of the transmitted signal without fading. To demonstrate the feasibility of RF transmission over fibre link for distribution of wireless signals, several simulative and experimental studies have been carried out to assess the single-input single-output (SISO) radio over fibre system via Alamouti's STBC codes with OFDM modulation. Despite the several advantages of transmitting the SISO-OFDM modulated signals, the performance of the conventional OFDM-RoF system is somehow limited, particularly in context to power- and spectral-efficiency. Moreover, the distribution of OFDM signals over a RoF link is critically affected by the optical sub-system non-linearity. In earlier reported research work, a significant diversity gain is achieved along with reduced non-linearity and phase-noise via 2x2 alamouti coding [12-13]. Further, an effective approach of synchronization of phase-noise is also proposed to moderate the phase-noise effect and to compensate the nonlinear impact of the optical sub-system over additive white Gaussian noise (AWGN) channel in MIMO-OFDM-RoF system but it increases the system complexity [14]. The supremacy of DWT transform over the discrete Fourier transform (DFT) is also discussed in [15-16] for transporting of OFDM signals over RoF link under the influence of optical sub-system non-linearity and phase-noise but is suitable for a specific channel scenario only. In [17], it is proposed to compensate the impact of optical non-linearity on OFDM signals using OSTBC. In [18], a novel 2x2 MIMO-OFDM based radio-over-fibre (RoF) system for 5G radio access network is proposed to optimize the operation cost in terms of power and spectrum consumption by considering the nonlinear distortion from optical modulator and high power amplifier. In [19], two different configurations of MIMO-OFDM-based RoF systems are compared for the long-term evolution (LTE) standard under different non-linearity levels, bandwidths, and fading-channel conditions. An appropriate quiescent point is determined in this work to decrease the impact of

non-linearity level and shows BER improvement by using Hammerstein type equalizer. In [20], the wavelet filter-bank employed OFDM is used to establish a power-efficient MIMO-RoF link via Rayleigh fading-channel. The results suggest the substantial compensation of frequency-selective fading and optical sub-system non-linearity as compared to the conventional OFDM.

However, the earlier reported work is demonstrated under a constant fading channel perception which is highly fluctuating in nature. So, a suitable link-adaptation strategy must be adopted via adaptive-selection of the modulation parameters, transmission-rate and transmit power in accordance with the channel fluctuations to realize a spectral-efficient RoF link with high link-reliability. These parameters are selected under some quality of services (QoS) constraints as per the channel state information (CSI) [11]. Some recent works with link adaptation have been discussed but are limited to the involvement of SISO antenna configuration only [21-22]. So, to realize a reliable RF transmission over RoF link with high spectral-efficiency, the authors implement wavelet employed MIMO-OFDM strategy with link-adaptive capability as per the situation of the wireless-link in this work. The link-adaptivity is carried out on the basis of transition-states derived by using classic threshold BER algorithm. The proposed system attains the spectral-efficiency ranging from 4 to 7 bits per symbol with link-adaptation in conjunction with link-quality to realize an economical approach. Further, the work is extended by evaluating the performance of the reported system for different wavelets under the impact of optical non-linearity in terms of power-penalty measurements i.e. E_b/N_0 (normalized signal-to-noise ratio) requirements to achieve a defined threshold BER. To retain the less-complex designing and evaluation of the demonstrated adaptive RoF system with self-recovery ability in accordance with the channel-conditions, the authors have considered the un-coded case in this work with the assumption that the inclusion of diverse channel-codes may further improve the BER performance of the proposed system as illustrated in earlier reported work [23-25]. The key parameters and their notations in the demonstrated RoF system are summarized in Table I. The proposed work is structured as: Section I describes the earlier reported work to be aware about the recent developments and requirements for realizing a spectral-and power-efficient RoF link to meet the demands of fifth-generation telecommunication industry; Section II highlights the major contribution of the proposed work; Section III describes the working principal of the proposed system briefly; Section IV presents the system description and its adaptive property in detail; Section V discusses about the result outcomes and is followed by the concluding part.

II. MAJOR CONTRIBUTIONS

The earlier reported work discussed in the introductory section of this work, demonstrates various attempts to realize a power- and spectral-efficient radio over fibre link

for meeting the demands of 5G applications. However, it is limited to establish a non-adaptive RoF system that provides the constant spectral-efficiency and is irrespective of the current channel-state. As the probability of fluctuations in the channel state of the wireless-channel is high, a reliable and spectral-efficient RoF link with self-adjusting capability in accordance with the current channel-situation is highly desirable. Subsequently, this work proposes an adaptive wavelet employed MIMO-OFDM radio over fibre system. The transmission of wavelet treated MIMO-OFDM signals with self-adjusting capability depending upon the channel situation is achieved on the basis of transition-states derived by means of classic threshold BER algorithm with the assumption of perfect channel-estimation. Further, to illustrate the effectiveness of the proposed system, the results are compared with non-adaptive radio over fibre system employed with M-PSK modulation schemes of different spectral-efficiencies reported in earlier literature. The performance assessment of the 2×2 Alamouti-coded W-MIMO-OFDM based RoF system is evaluated in terms of power penalty i.e. E_b/N_0 (normalized signal-to-noise ratio) requirements to achieve the specified threshold BER for several wavelets.

TABLE I
KEY PARAMETERS

Notation	Quantity	Values
X_n^m	User symbol-vector	12800
N_t	Number of transmit antennas	2
N_r	Number of receive antennas	2
M	Number of subcarriers	256
$\Psi_{m,n}(t)$	Mother wavelet	Haar, Db, Sym, Coif, Dmey, Bior, Rbio
L	Fibre length	10 Km
D	Fibre dispersion	17 ps/nm.Km
α	Fibre loss	0.2 dB/Km
γ	Fibre non-linearity	$2.2 \times 10^{-20} \cdot \text{m}^2 \cdot \text{W}^{-1}$
λ	CW Laser operating wavelength	1550nm
$\Delta\lambda$	CW Laser linewidth	10 MHz
P	CW Laser power	0 dBm
R	Responsivity	1 AW ⁻¹
$IIP3$	3rd order input intercept point	25 dBm

III. WORKING PRINCIPLE

The proposed system presents an end-to-end transmission of RF signals over the wireless fading channel through the radio over fibre link using MATLAB software as shown in Figure 1. The initial stage of this work is developed by generating MIMO-OFDM signals which is carried out by mapping the user data-bits to a suitable constellation scheme via M-PSK modulator bank. After mapping, the symbol-data is encoded using Alamouti STBC codes to implement 2×2 MIMO spatial diversity. Thereafter, the encoded data is subjected to IDWT to generate wavelet-OFDM multicarrier signals. These wavelet treated MIMO-OFDM signals are, then, transmitted over RoF link via intensity-modulation using a continuous light source.

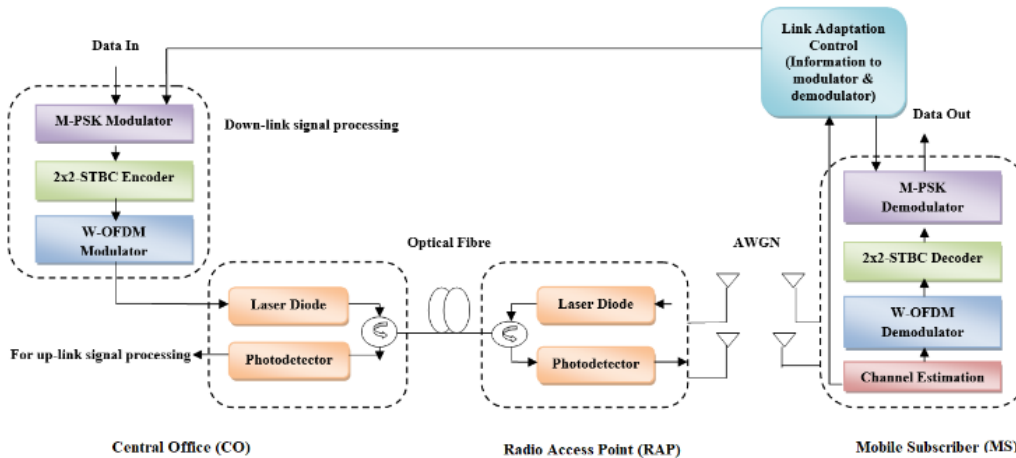

FIGURE 1. Schematic Diagram of proposed Adaptive W-OFDM-MIMO-RoF System

On the alternative-end of RoF link, the radio access points (RAPs) are connected to receive the optical signals and are reconverted back into electrical RF signals using photodetectors. The subsequent RF signals are transmitted over a wireless channel by means of two transmit-antennas. The authors developed a multi-fading wireless channel with additive white Gaussian noise (AWGN). The mobile subscriber (MS) receives the MIMO-OFDM signals via two receive-antennas. The received signals are processed using demodulation-and decoding- process to recover the original transmitted user-data. As the wireless channel is highly adaptable to multi-path fading and other atmospheric variations, there is a high probability of signal reception with low signal-to-noise ratio along with high bit-error-rate. So, the non-adaptive RoF links, designed for a specific application becomes inefficient under the severe channel variations. To deal with it, the authors develop an adaptive RoF that possess a self-recovering ability in accordance with the atmospheric condition to offer a power-and spectral-efficient transmission-link to the users. To attain this ability, the receiver is equipped with a feedback mechanism that continuously updates the transmitter about the received SNR i.e. about channel condition. On the basis of this received SNR data, the transmitter-and receiver-subsystems switch to a suitable modulation scheme to ensure the BER below the specified threshold value.

IV. SYSTEM SETUP

The proposed MIMO-OFDM-RoF system is developed by means of MATLAB software in which the wavelet employed MIMO-OFDM signals are transmitted over a wireless channel through a RoF link. A random source is used to generate user-data and is mapped onto PSK modulation scheme. The authors implement constant envelope PSK due to its less linearity requirements in contrast to non-constant envelope quadrature amplitude modulation (QAM) scheme. The linearity requirements of a modulation scheme affect the power-efficiency of the transmission system significantly and the PSK scheme has

the potential to offer better performance in terms of power-consumption and energy-efficiency [26].

On the other hand, PSK schemes are more susceptible to phase-noise than QAM and to overcome this phase-noise issue, the proposed system is employed with discrete wavelet transformation (DWT) that has ability to perform efficiently even under the influence of phase-noise [15]. The 2×2 MIMO is employed using Alamouti algorithm to ensure the spatial diversity by means of 2×2 antenna-module in this work. The authors use 2×2 antenna-module using alamouti codes as an exponentially upsurge of system-complexity is observed with an increase of number of antennas [27]. Moreover, more than two antennas limits the maximum possible rate to $\frac{3}{4}$ and the designed codes for more than two antennas possess long block-length that results in a longer decoding delay. These Alamouti STBC encoded user symbols are transmitted through the wireless channel by means of two antennas in two symbol-periods to attain full-rate diversity. During I^{st} symbol-period, the symbols S_1 and S_2 are transferred simultaneously, though in the II^{nd} symbol-period, these symbols are again communicated as $-S_2^*$ from the I^{st} antenna and as S_1^* from the other. The orthogonal codes with 4^{th} order full-diversity at full-rate is expressed as [27]:

$$G = \begin{bmatrix} S_1 & S_2 \\ -S_2^* & S_1^* \end{bmatrix} \quad (4)$$

Generally, for a MIMO-OFDM system with N_t = number of transmit antennas, and n = number of symbols, the transmitted symbol-vector is represented [28] as

$$X_n^m = [X_{n1}^m \ X_{n2}^m \ \dots \ X_{nN_t}^m]^T \quad (5)$$

where, $m = 0, 1 \dots M - 1$; M = number of subcarriers. The OFDM symbols are generated using 256-point IDWT. The IDWT modulator accepts the encoded data symbols as a sequence of wavelet and approximation-coefficients. If X_n^m

represents DWT coefficients at dissimilar scale- and time-variables, then IDWT of X_n^m is computed [6, 9] as:

$$x(t) = \sum_{m \in M} \sum_n X_n^m \Psi_{m,n}(t) \quad (6)$$

Where, $\Psi_{m,n}(t)$ = Mother wavelet

For IDWT computation, diverse mother wavelets, for instance, Daubechies, Symlets, Coiflets, Dmey and Bi-orthogonal are considered to observe the influence of the nature and order of the wavelets over the performance of the demonstrated RoF system. Thereafter, this generated wavelet employed MIMO-OFDM signal is transmitted over a fibre-link (standard single mode fibre-SSMF) using a CW laser-diode (CW-LD) with operating wavelength=1550 nm; linewidth = 10 MHz; Power = 0 dBm and the photodetector. Additionally, the non-linearity affects the high-quality transmission of RF signals over the link that may come into picture from light-source itself or both from laser and fibre [29-30]. So, to observe the performance of the reported RoF transmission under the influence of the non-linearity that causes phase-noise, the system is modelled by memory-less nonlinearity. For modelling the memory-less non-linearity, there are a number of methods like cubic polynomial based model, Saleh model, Rapp model, Hyperbolic Tangent. Based on the previous research work on RoF non-linearity [29-32], the authors have utilized the cubic polynomial method to develop the RoF system to include the non-linearity and is approximated by using AM-AM/PM behavioural model [33-34]. In general, a polynomial of q^{th} degree is expressed as:

$$y(t) = \sum_{k=1}^{q+1} p_k x(t)^{q+1-k} \quad (7)$$

Where, $q + 1$ = polynomial order; q = degree of polynomial and the solution for the cubic polynomial is reduced to equation (8) which represents the output of the RoF link in response to the MIMO-OFDM signal $x(t)$ of equation (6) [34]:

$$y(t) = p_1 x(t)^3 + p_2 x(t)^2 + p_3 x(t) + p_4 \quad (8)$$

In cubic polynomial method, the AM-AM non-linearity of RoF link is characterized using 3rd order input intercept point (IIP3). The third-order intercept point relates nonlinear products caused by the 3rd order nonlinear term of equation (8) to the linearly processed signal. Usually, the RoF link characterized by IIP3 value of more than 35 dBm that indicates the highly linearized behavior of the link [35]. So, the authors illustrate the non-linearity of RoF link by keeping IIP3 value of 25 dBm to compute the performance of the reported work in the presence of non-linearity [32, 36]. A continuous-wave laser-diode (CW-LD) is used to achieve the light-intensity modulation to generate intensity modulated MIMO-OFDM signals. These modulated optical signals are transmitted over conventional

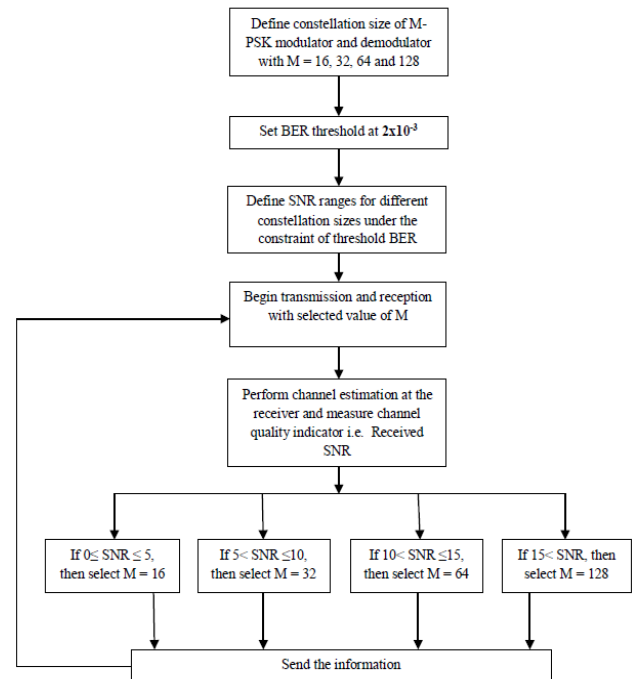

FIGURE 2. Flow chart for Link Adaptation strategy.

single-mode fibre (SSMF) of 10 Km length with dispersion parameter, $D = 17$ ps/nm.km, loss, $\alpha = 0.2$ dB/Km, fibre non-linearity, $\gamma = 2.2 \times 10^{-20}$.m².W⁻¹. On alternative-end of fibre i.e. at the radio access point (RAP), the received signal is converted back to RF signal using photodetector with responsivity (R) as unity. Subsequently, the reconstituted RF signals are propagated wirelessly over frequency-selective Rayleigh fading channel of 2-m length by two transmit antennas. The signal at the user-equipment is appeared as:

$$z(t) = y(t) * H(t) + W(t) \quad (9)$$

where, $H(t)$ is the impulse response of frequency-selective MIMO channel, $W(t)$ is the additive white Gaussian noise. At the user-equipment, the channel approximation is implemented using maximum likelihood algorithm. The OFDM signal is demodulated using the DWT algorithm and decoded using STBC combiner. Finally, the serial data is fed to the single carrier demodulator to recover the original information and is analyzed using BER analyzer.

In addition to the evaluation of the proposed MIMO-OFDM-RoF system with a fixed modulation scheme for diverse wavelets, the feature of link adaptation is also incorporated by employing M-PSK modulator and demodulator banks for diverse PSK modulation schemes, for instance, 16-PSK, 32-PSK, 64-PSK and 128-PSK. Link-adaptivity is attained according to the SNR range derived at the user-end using the classic threshold BER algorithm. This algorithm utilizes estimated received SNR and is fed back to the transmitter as a feedback signal. This feedback signal awares the transmitting section about the wireless link scenario in terms of BER. Accordingly, the

transmitting section tunes to a suitable modulation scheme ensuring the maintenance of minimum threshold BER to achieve the optimal data reliability needs. The minimum threshold value is taken as 2×10^{-3} in this work [30]. The adaptive strategy is illustrated in flow chart in Figure 2. Under high-quality channel conditions, the transmitting module opts for higher-level modulation schemes such as 64-PSK, 128-PSK. However, in case of worst channel scenarios, the transmission is tuned to the lower-level modulation schemes, for instance, 16-PSK and 32-PSK.

V. RESULTS

As the wavelet-OFDM has the potential to generate small side-lobes, offering low PAPR and avoids the bandwidth wastage due to CP extension in conventional OFDM [5-6], the authors, initially, assess the proposed non-adaptive MIMO-OFDM-RoF system by introducing diverse wavelets, for instance, Daubechies, Symlet, Coiflet and Dmey. The system performance is calculated in terms of BER as a function of E_b/N_o to ascertain the optimal wavelet to be implemented to comprehend a power-efficient and spectral-efficient RoF system. The evaluation is carried out with 16-PSK modulation with 1st order wavelets i.e. db1 (also known as haar), Sym1, Coif1 and Dmey as shown in Figure 3.

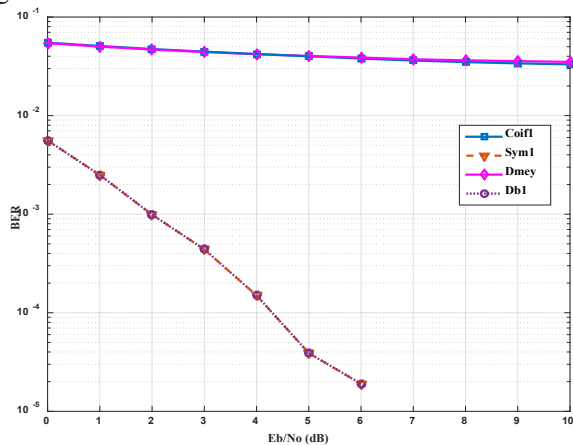

FIGURE 3. Wavelet-OFDM-MIMO-RoF system with diverse orthogonal wavelets

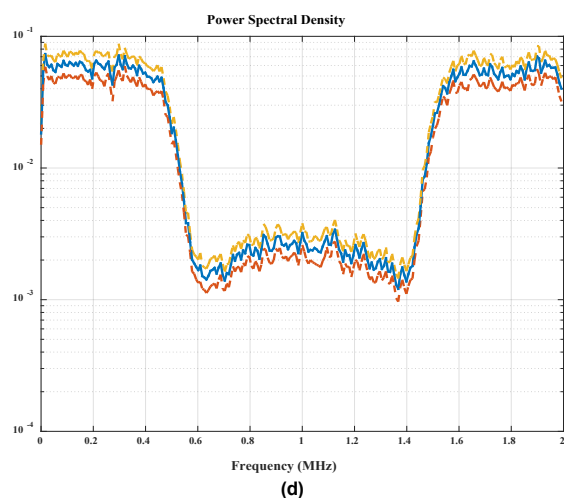
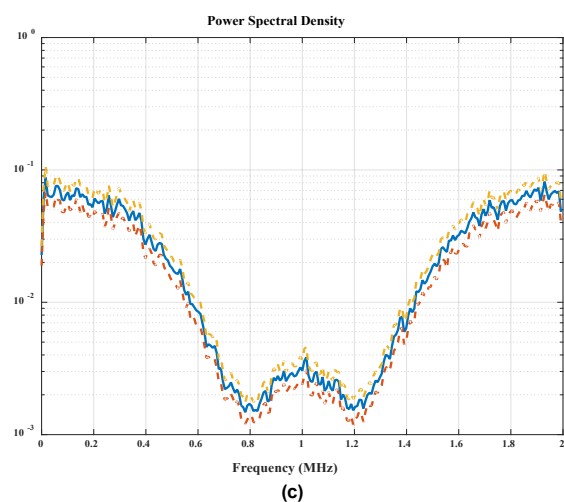
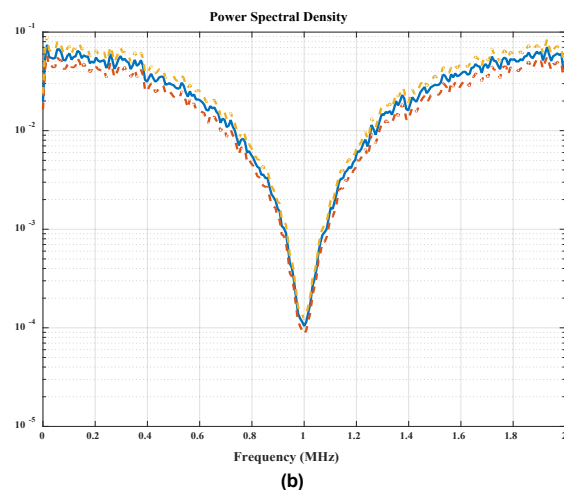
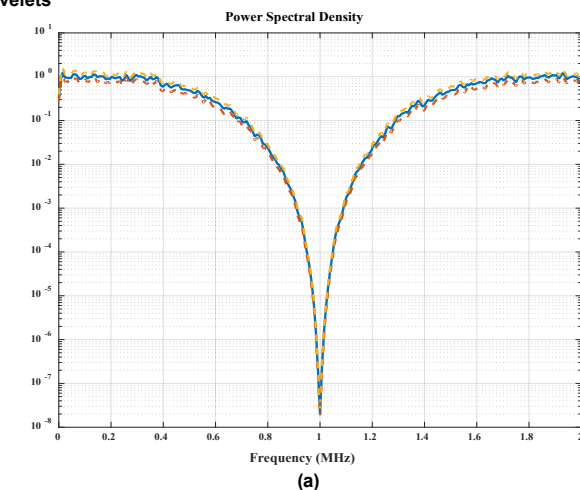
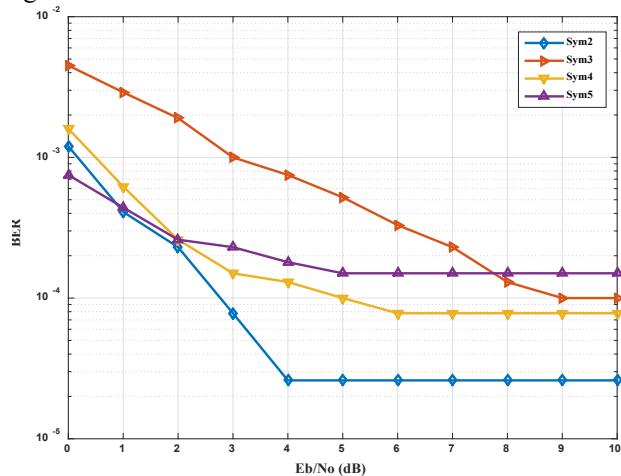

FIGURE 4. Power spectral density (PSD) spectra for the proposed system with 16-PSK modulation for (a) Transmitted signal (b) Received signal with db1/sym1 (c) Received signal with coif1 (d) Received signal with dmey wavelet.

Results shows that the db1 and sym1 wavelet exhibits the identical BER characteristics as the symlet wavelet is the near-symmetric version of daubechies wavelet and requires a power penalty of approximately 1.5 dB only to achieve

the threshold BER. Further, it is observed that the proposed system exhibits an irreducible BER characteristic with *coif1* and *dmev* wavelets as both of these wavelets possess relatively large number of vanishing moments, large support-width and poor spectral-containment [10]. The power spectral density of these wavelets is depicted in Figure 4.



(a)

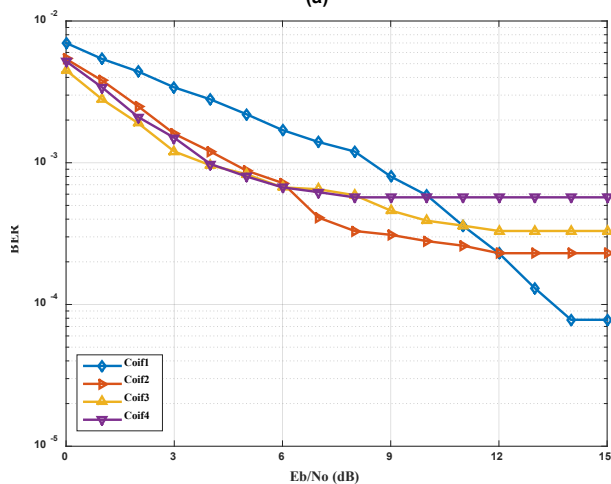

(b)

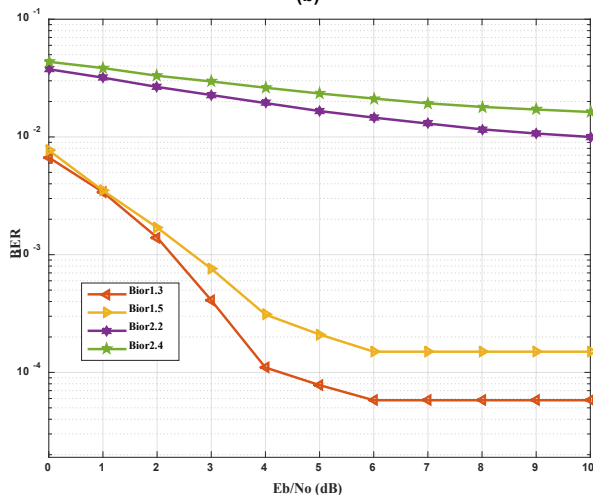

(c)

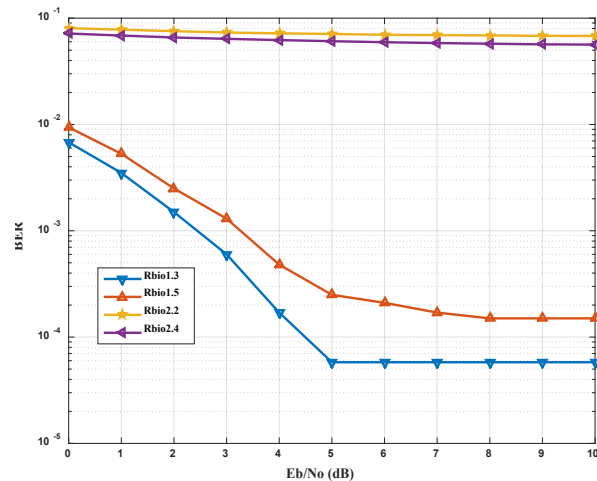

(d)

FIGURE 5. Wavelet-OFDM-MIMO-RoF system with different orders of (a) symlet wavelet using 8-PSK; (b) coiflet wavelet using 8-PSK; (c) biorthogonal wavelet using 16-PSK; (d) reverse biorthogonal wavelet using 16-PSK

Furthermore, to assess the impact of wavelet order, the reported work is extended to investigate the influence of wavelet-order for orthogonal and bi-orthogonal wavelets. Out of the orthogonal wavelets, Symlet and Coiflet wavelets are investigated with different orders, for instance, *sym2*, *sym3*, *sym4*, *sym5*, *coif1*, *coif2*, *coif3* and *coif4* as shown in Figure 5. As the BER performance of the coiflet- and sym- wavelet is observed marginally low with 16-PSK modulation, the authors measured the system performance with 8-PSK scheme at different wavelet-orders as shown in Figure 5 (a-b). Results show that a power penalty of 2.5 dB is measured with second-order symlet-wavelet to achieve the BER of 10^{-4} for the proposed system, which is marginally low in comparison with the other symlet-wavelets. Further, the high-power penalty requirements are observed to achieve the desired threshold BER for coiflet family. This may be due to increase in filter-length and number of vanishing moments with the increase of wavelet-orders [10]. For bi-orthogonal wavelets, a slight increase of power penalty is observed to achieve the minimum threshold with the increase of order of bior-wavelet from 1.3 to 1.5. This may be due to the increase of filter-length from (3, 7) to (3, 11) with increase of wavelet-order. For *bior1.3*- and *bior1.5*- wavelets, the measured BER saturates near 10^{-4} at power penalty of 6 dB while *bior2.2*- and *bior2.4*- wavelets show an irreducible BER characteristic as shown in Figure 5 (c). Moreover, the authors observe an increase in system-complexity with an upsurge of filter-length requirements for higher order wavelets e.g. *bior1.3* demands a filter-length of (4, 8) while *bior2.4* requires a filter-length of (6, 10). Also, with reverse bi-orthogonal wavelets, an approximately same power penalty is measured for achieving the minimum threshold as shown in Figure 5 (d). It has been also observed that the odd-order bi-orthogonal and reverse bi-orthogonal wavelets outperform the even-order wavelets. Collectively, it has

been observed that while selecting a suitable wavelet to establish a power-efficient transmission link, one must consider the type and order of the wavelet. For power-efficient system, the lower order orthogonal wavelets Sym2 and Coif1 are recommended while to establish a spectral-efficient transmission link at marginal power penalty, wavelets like Bior1.3 and Rbio1.3 are the suitable options.

To evaluate the influence of imperfect channel-estimation and carrier frequency-offset, the proposed system is analyzed for different values of phase-error which collectively represents the phase-offset due to phase estimation errors and carrier frequency-offset. The BER characteristics for 16-PSK modulated system with db1 (Haar) and Bior1.3 wavelets are depicted in Figure 6(a-b). In case of both the wavelets, it is observed that for a phase error of 2.86 and 5.72 degrees, the power penalty to achieve threshold BER is increased by 0.7 and 2 dB respectively in contrast to perfect estimation case, however, when phase error is increased to 8.59 degrees, the Bior1.3 wavelet imposes higher power penalty than that of db1 wavelet. It can be concluded that proposed system is more robust to large phase errors with db1 wavelet.

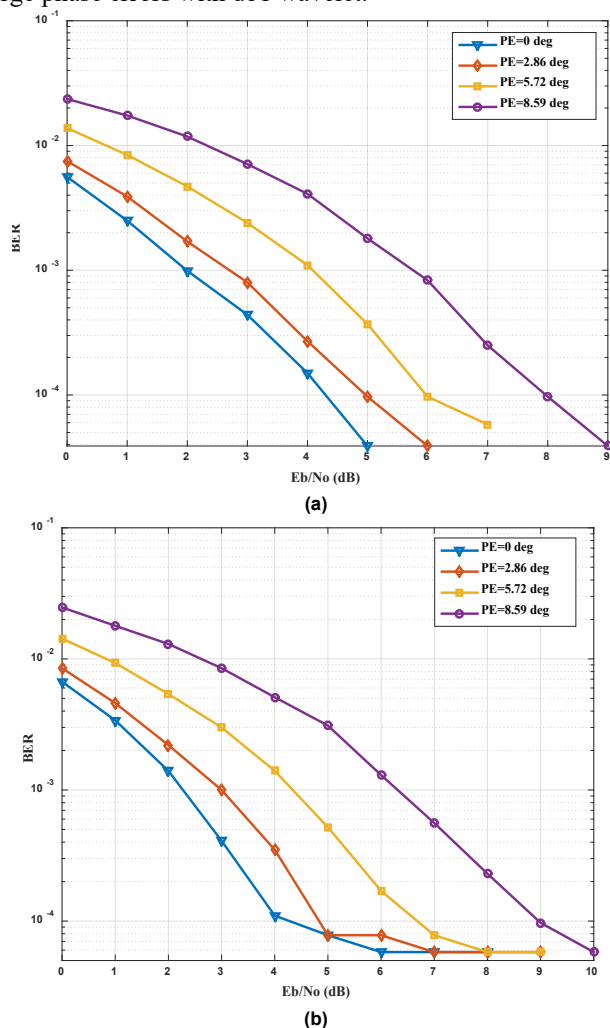

FIGURE 6. Wavelet-OFDM-MIMO-RoF system with different phase errors for (a) db1 (Haar) wavelet (b) Bior1.3 wavelet

Furthermore, keeping in view the superior BER performance of non-adaptive RoF system using db1 (Haar) wavelet as shown in Figure 3, this work is extended to implement the developed link adaptive strategy with db1 wavelet. To show the effectiveness of the proposed adaptive strategy in contrast with non-adaptive conventional system, the BER performance as a function of E_b/N_0 is calculated as shown in Figure 7. It is observed that the proposed adaptive system exhibits a spectral-efficiency of 4 to 7 bits per symbol at varied propagation conditions. The transmission link establishment using 128-PSK modulation to target the minimum BER threshold requires SNR of 17 dB with spectral-efficiency of 7 bits per symbol. However, as the received SNR deteriorates due to propagation channel impairments, the system becomes incapable to maintain the BER above the threshold BER i.e. 10^{-3} . So, the adaptiveness of the proposed strategy enables the transmitting-and-receiving-module to switch over to 64-PSK modulation without disturbing the transmission link to achieve the threshold value. For SNR of the transmission link from 11 dB to 15 dB, the transmission is sustained with 64-PSK modulation. As soon as the system becomes unable to maintain the threshold BER again due to the influence of degrading properties of the wireless-channel, the system is switched to the lower available modulation scheme i.e. 32-PSK to sustain the transmission link by maintaining the required threshold values as shown in Figure 7. Results also show that the minimum BER of about 10^{-5} is achievable by the proposed system for 16-PSK, 32-PSK, 64-PSK and 128-PSK independently at a power penalty of 5 dB, 10 dB, 15 dB and 20 dB respectively.

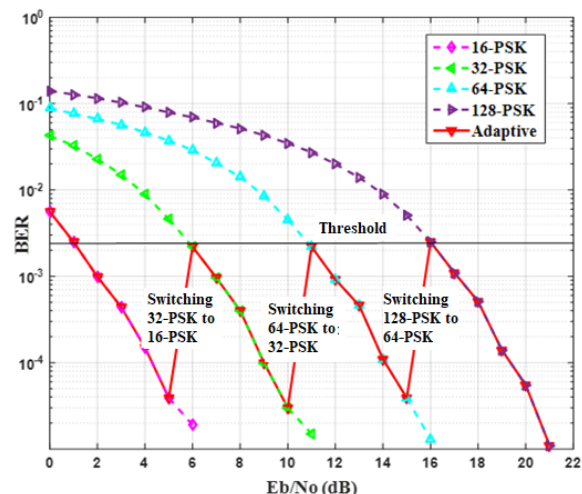

FIGURE 7. Wavelet-OFDM-MIMO-RoF system with adaptive and diverse fixed PSK modulation schemes using Haar wavelet

Moreover, the proposed system outperforms by introducing the self-recovery property that provides the transmission link availability constantly by switching between the best available M-PSK techniques in accordance with the environment perceptions. Moreover, the demonstrated adaptive W-MIMO-OFDM-RoF system offers better spectral-efficiency along with link-quality in contrast with the fixed modulation employed RoF system as

the later system shows high outage probability i.e. below the SNR of 16 dB and 11 dB even in the case of highly spectral-efficient scheme like 64-PSK and 128-PSK as shown in Figure 7. For low-order PSK schemes i.e. 16-PSK and 32-PSK, the demonstrated system retains the transmission link quality at the minimal requirements of SNR at the receiver but at the cost of conceded spectral-efficiency.

VI. CONCLUSION

A 2x2 Alamouti coded Wavelet-OFDM-MIMO-RF transmission over fibre is demonstrated in this work to produce small side-lobes, low PAPR together with high power-efficiency by incorporating diverse wavelets. Based upon the comprehensive exploring of the outcomes, it is suggested to implement db1 wavelet in orthogonal category and wavelets of order 1.3 in bi-orthogonal or reverse bi-orthogonal category to establish a spectral- and power-efficient transmission-link. Further, a 2x2 Alamouti coded Wavelet-OFDM-MIMO-RF transmission over fibre employed with self-link-adaptive property is also demonstrated in this work using db1 wavelet. The transition thresholds for switching to a suitable M-PSK modulation scheme are derived using classic threshold BER algorithm and the transmission adapts according to the channel conditions to realize the optimum quality of link-connectivity with high spectral-efficiency required for 5G applications. The outcomes show that the proposed adaptive system achieves spectral- efficiency of 4 bits per symbol to 7 bits per symbol while maintaining the link-quality. In future, the proposed work may be extended in the arena of photonic based radar detection and ranging with high image-resolution and range-accuracy by introducing of ultrashort pulse-lasers to be utilized in security systems, autonomous vehicles, biomedical-imaging and remote-sensing areas.

ACKNOWLEDGMENT

This work is carried out in Aston Institute of Photonic Technologies, Aston University, Birmingham, UK and is supported by European Union sponsored H2020-MSCA-IF-EF-ST project.

REFERENCES

- [1] G. Chang, and L. Cheng, "Fibre-wireless integration for future mobile communications," *IEEE Radio and Wireless Symposium (RWS)*, Phoenix, AZ, 2017, pp. 16-18, <https://doi.org/10.1109/RWS.2017.7885932>
- [2] Sharma V., Singh A., Sharma A.K., "Challenges to Radio over Fibre (RoF) Technology and its Mitigation Schemes-A Review," *Optik-International Journal for Light and Electron Optics*, vol. 123, no. 4, pp. 338-342, 2012, <https://doi.org/10.1016/j.ijleo.2011.02.031>
- [3] A. Aighobahi, and N.J. Gomes, "Capacity and Error Performance Verification of Multi-Antenna Schemes in Radio-over-Fibre Distributed Antenna System," *Journal of Lightwave Technology*, vol. 34, no. 20, pp. 4779-4785, 2016
- [4] L. C. P. Cavalcante, S. Rommel, R. Dinis, L. G. Q. S. Junior, L. F. Q. Silveira, and I. T. Monroy, "Performance Evaluation of Wavelet-Coded OFDM on a 4.9 Gb/s W-Band Radio-Over-Fibre Link," *Journal of Lightwave Technology*, vol. 35, no. 14, pp. 2803-2809, 2017
- [5] B. Farhang-Boroujeny, and C.H. Yuen, "Cosine Modulated and Offset QAM Filter Bank Multicarrier Techniques: A Continuous-Time Prospect," *EURASIP Journal on Advances in Signal Processing*, pp. 1-16, 2010, doi:10.1155/2010/165654
- [6] G. Manasra, O. Najajri, H. A. Arram, and S. Rabah, "Multicarrier QAM Modulation Based on Discrete Wavelet Transform Using Wireless MIMO System," in *Proc. IEEE Palestinian International Conference on Information and Communication Technology*, 2013, pp. 77-82
- [7] R. Van Nee and R. Prasad, "OFDM for Wireless Multimedia Communications," Artech House, Boston, Mass, USA, 2000.
- [8] Y. Li and G. L. Stuber, "Orthogonal Frequency Division Multiplexing for Wireless Communications," Springer, New York, USA, 2006
- [9] A. Deshmukh, "Performance Evaluation of OFDM based Wireless System Working in the Frequency Band of 60 GHz," Ph.D. Thesis, Usha Mittal Institute of Technology, SNDT Women University, India, 2012
- [10] X. Pan, "Thesis Report on M-ary Orthogonal Modulation using Wavelet Basis Functions," Ohio University, 2000
- [11] M. Torabi, and C. Nerguizian, "Adaptive Transmission in Spectrum Sharing Systems With Alamouti OSTBC Under Spatially Correlated Channels," *IEEE Transactions on Vehicular Technology*, vol. 66, no. 4, pp. 3131-3142, 2017
- [12] U. Habib, A.E. Aighobahi, C. Wang, and N.J. Gomes, "Radio over fibre transport of mm-wave 2x2 MIMO for spatial diversity and multiplexing," in *Proc. International Topical Meeting on Microwave Photonics (MWP)*, CA, USA, 2016
- [13] M. El Yahyaoui, A. El Moussati, and G. El Zein, "On the Capacity of MIMO-OFDM based Diversity and Spatial Multiplexing in Radio over Fibre system," *Optics Communications*, vol. 402, pp. 252-259, 2017,
- [14] M. Najafi, G. Baghersalimi, M.R. Alizadeh, M. Rahimi, and A. Burton, "Synchronization of a MIMO-OFDM based Radio over Fibre communication system in the presence of phase noise," in *Proc. 10th IEEE International Symposium on Communication Systems, Networks and Digital Signal Processing*, pp. 1-5, 2016
- [15] G. Baghersalimi, "Performance assessment of OFDM-based and OWDM-based Radio over Fibre systems in the presence of phase noise," in *Proc. 3rd International Congress on Ultra-Modern Telecommunications and Control Systems and Workshops (ICUMT)*, pp. 1-5, 2011
- [16] G. Baghersalimi, "A comparative performance study of optical subsystem equalization in OFDM-based and OWDM-based Radio-over-Fibre systems," in *Proc. 11th international conference on Telecommunications*, pp. 315-320, 2011
- [17] M.R. Alizadeh, G. Baghersalimi, M. Rahimi, M. Najafi, and X. Tang, "Performance Improvement of a MIMO-OFDM based Radio over Fibre System using Alamouti Coding: AWGN Scenario," in *Proc. 10th IEEE International Symposium on Communication Systems, Networks and Digital Signal Processing*, pp. 1-5, 2016
- [18] B.Wang, L. Peng, & P. Ho, Energy-efficient radio-over-fiber system for next-generation cloud radio access networks. *J Wireless Com Network* 2019, 118 (2019) doi:10.1186/s13638-019-1457-6.
- [19] M. Alizadeh, G. Baghersalimi and M. Nassiri, "Performance evaluation of 2x2 MIMO-OFDM-based radio-over-fibre system using Alamouti coding and Hammerstein equaliser," in *IET Communications*, vol. 13, no. 9, pp.1171-1178, 2019. doi: 10.1049/iet-com.2018.5692
- [20] J. Kaur, V. Sharma, "A-STBC incorporated power-efficient Radio over Fibre system," *Optics Communications*, vol. 441, pp. 84-89, 2019
- [21] B. Umasankar, A.D.S. Jayalath, and X. Fernando, "Adaptive performance improvement of OFDM Radio over Fibre systems," in *Proc. International Symposium on signals, systems and electronics*, 2007, pp. 611-614
- [22] N. Kang, X. Sun, J. Liang, and W. Gu, "Performance improvement of OFDM-RoF system with combined adaptive modulation," in *Proc. Global Mobile Congress*, 2009, pp. 1-4

- [23] S. Y. Ameen and W. A. H. Hadi, "Investigation of using Turbo Code to Improve the Performance of DWT-OFDM System over Selective Fading Channel," 2006 2nd International Conference on Information & Communication Technologies, Damascus, 2006, pp. 2365-2369. doi: 10.1109/ICTTA.2006.1684776.
- [24] H. Zhang, D. Yuan, M. Jiang and D. Wu, "Performance comparison of WOFDM with different coding schemes," Radio and Wireless Conference, 2003. RAWCON '03. Proceedings, Boston, MA, 2003, pp.59-62. doi: 10.1109/RAWCON.2003.1227892
- [25] H.A.Raweshidy & S. Komaki, (2002). Radio over Fiber Technologies for Mobile Communications Networks, Artech House, London.
- [26] H. Men, M. Jin, A Low-Complexity ML Detection Algorithm for Spatial Modulation Systems With MPSK Constellation, IEEE Communications Letters, 18(8)(2014), 1375 – 1378. <https://doi.org/10.1109/LCOMM.2014.2331283>.
- [27] G. Tsoulos, "MIMO System Technology for Wireless Communications," CRC Press, 2006
- [28] A. Bouhleh, A. Sakly, and N. Mansouri, "Performance Comparison of DWT based MIMO OFDM and FFT based MIMO OFDM," Procedia Computer Science, vol. 73, pp. 266-273, 2015
- [29] C. Lee, V. Postoyalko, and T. O'Farrel, "Analysis and Simulation of AM-AM/PM Non-linear Distortion due to Direct Laser Modulation in Radio over Fibre Systems," in *Proc. International Topical Meeting on Microwave Photonics*, 2002, pp. 137-140
- [30] G. Baghersalimi, T. O'Farrell, and T. V. Postoyalko, "Modelling Laser-Diode Non-linearity in a Radio over Fibre Link," in *Proc. London Communication Symposium*, 2003, pp 321-324
- [31] X. Zhang, R. Zhu, D. Shen and T. Liu, Linearization Technologies for Broadband Radio-Over-Fiber Transmission Systems, *Photonics*, 1, 455-472, 2014
- [32] X. N. Fernando, "Radio over Fibre for Wireless Communications," John Wiley & Sons Ltd, 2014
- [33] X. N. Fernando, and A.B. Seasay, "Characteristics of Directly Modulated RoF Link for Wireless Access," in *Proc. Canadian Conference on Electrical and Computer Engineering*, pp. 2167-2170, 2004
- [34] A. Gameiro, and N. Gomes, "Fibre Optic Networks for Distributed and Extendible Heterogeneous Radio Architectures and Service Provisioning: D3.2 Model of signal distortion due to the RF/optical interface and the fibre network," FUTON FP7 ICT-2007-215533 report, 3rd December 2008
- [35] A. Nikolov, "Radio over Fibre Technology for 5G Cloud-Radio Access Network Front haul," APIC Corporation, pp.1-8, 2017, www.apichip.com
- [36] G. Baghersalimi, T. O'Farrell, and V. Postoyalko, "A Performance Assessment of Narrowband Modulation Schemes over the Flat Rayleigh Fading Channel in Radio over Fibre Communication Systems," in *Proc. London Communication Symposium*, 2005, pp. 215- 218



Sharma, Vishal conceded his doctorate in Engineering in 2013 and Masters of Technology in the field of Electronics and Communication in 2007 from IKG Punjab Technical University, India. Currently, he is a Marie Skłodowska Curie Fellow in Aston institute of Photonics technologies (AiPT), School of Engineering and Applied Science, Aston University, Birmingham, U.K. He is also deputed as

Associate Professor in State Government Engineering Campus after the name of Bhagat Singh State Technical campus (SBSSTC) in Ferozepur since 2009. His specialization of research areas are Ultra-short pulse laser designing, Photonic Radar, Radio over Fiber (RoF) systems, Photonic-Microwave Networks, Passive Optical Networks (PON), Free Space Optics (FSO), Inter-satellite optical wireless systems (IsOWC), Wireless Sensor Networks (WSN), Hybrid wireless- and wired-systems.



Sergeyev, Sergey received M.Sc. and Ph.D. degrees from Belarussian State University (BSU), Minsk, Belarus, in 1985 and 1991, respectively.

He was with the Department of Physics, BSU, from 1985 to 1999. From 1999 to 2005, he was with Ericsson AB, Stockholm, Sweden, the Royal Institute of Technology, Stockholm, and Acreo AB, Stockholm.

From 2005 to 2010, he was with the Optics Research Group, Waterford Institute of Technology, Waterford, Ireland, as a Senior Researcher and Project Manager. He has been a Marie Curie Research Fellow with the Photonics Research Group, Aston University, Birmingham, U.K., since 2010. Currently, he is working as Associate Research Professorial Fellow (since 2018) in Aston institute of Photonics technologies (AiPT), School of Engineering and Applied Science, Aston University, Birmingham, U.K. He has co-authored over 90 journals and conference papers in the areas of fiber optics, laser physics, and spectroscopy.



Kaur, Jaswinder is a research scholar of IKG Punjab Technical University, India and completed her Masters of Technology in the field of Electronics and Communication in 2006 from IKG Punjab Technical University, India.

Currently, She is deputed as Associate Professor in State Government Engineering Campus after the name of Shaheed Bhagat Singh State Technical campus (SBSSTC) in

Ferozepur since 2005. Her specialization of research areas are Radio over Fiber (RoF) systems, Photonic-Microwave Networks, Hybrid Wireless- and Wired-systems.