

Receiver Memory Requirement in Mode Delay Compensated Few-Mode Fibre Spans with Intermediate Coupling

Christian S. Costa, Filipe M. Ferreira, Naoise Mac Suibhne, Stylianos Sygletos, Andrew D. Ellis
Aston Institute of Photonic Technologies, Aston University, Birmingham, UK

(c.sanchez-costa@aston.ac.uk)

Abstract *The required receiver time window after propagation through few-mode fibre is studied for a broad range of coupling and mode delay span configurations. Under intermediate coupling, effective mode delay compensation is observed for a compensation period of 25km.*

Introduction

Spatial-division multiplexing (SDM) has received great attention as a promising way to increase system capacity. Parallel transmission of N information signals can be accomplished by exploiting the guiding modes of a few-mode fibre (FMF). However, the optical link and transceiver must be designed in order to cope with the arising impairments, such as modal coupling and differential mode delay (DMD). Approaches to reduce the complexity of the digital signal processing (DSP) needed to compensate for these impairments have been proposed. Namely, the employment of fibres with opposite DMD sign¹, and the propagation of the signals with strong mode coupling along the fibre^{2,3}, aim to reduce the total undergone DMD, and, thus, the length of multiple-input multiple-output (MIMO) equalizer used at the receiver. However, which technique is more favourable in terms of performance and DSP complexity for each scenario requires further investigation.

In this paper we study through exhaustive simulations the required memory length of the receiver DSP to ensure a minimum acceptable performance in a variety of coupling strength and DMD conditions of a 100km 3-mode fibre, including SDM systems with DMD management.

SDM system model

The simulated SDM system is shown in Fig. 1. Six 28GBd quadrature phase-shift keyed (QPSK) signals are transmitted on the two polarizations of the mode LP_{01} and the two degenerated modes of LP_{11} , yielding a total bit rate of 336Gb/s. Together with the information data, a preamble is transmitted consisting of constant amplitude zero autocorrelation (CAZAC) sequences, used at the receiver for time synchronization and channel estimation. Each of the signals drives an ideal laser through an optical IQ modulator, and then it is launched into the FMF. The dispersion parameter is equal to 21.79 ps/(km·nm) and 22.14 ps/(km·nm) for the two degenerated modes LP_{11} and LP_{01} , respectively.

The fibre is assumed to be linear and lossless, since we are interested only on the combined impact of mode coupling and the DMD effects on the receiver complexity. The FMF model is based on dividing the fibre in multiple sections, each with a constant random displacement of the core centre position⁴. The model also considers random displacement of the radial and azimuthal coordinates between consecutive sections. The mode coupling strength (XT) is quantified as $XT_m = \sum_{n \neq m} P_n / P_m$ where P_n is the power of mode n , after a given segment under test, when only mode m was launched. The dependence of the coupling strength on the fibre displacement can be found in⁵. The coupling strength has been proven to be an essential factor on the distribution of the GDs³, having been demonstrated theoretically the beneficial effects of strong mode coupling to shrink the probability distribution of its spread. For this reason, XT is swept within a broad range of values, covering the weak, intermediate and strong coupling regimes. Furthermore, we also studied the effectiveness of using fibres with GD of opposite sign. To do so, the 100km of FMF is divided into a number of segments with the same length, where each segment comprises two fibres with GD of opposite sign. After homodyne detection, the baseband electrical signals are sampled at 56Gsam/s, yielding six digital signals with 2samples/symbol. The first stage of the DSP is the compensation of chromatic dispersion (CD). The beginning of the frame is detected using an autocorrelation metric⁶. After the calculation of the coarse time synchronization, the 6×6 channel impulse responses (CIR) are estimated. Using the previously calculated coarse time synchronization as reference, a time-finite window of received samples is used for channel estimation in the time domain. These CIR estimations are converted into the frequency domain. The MIMO frequency domain equalizer is calculated by inverting the channel matrix, and, finally, the total Q-factor is computed by

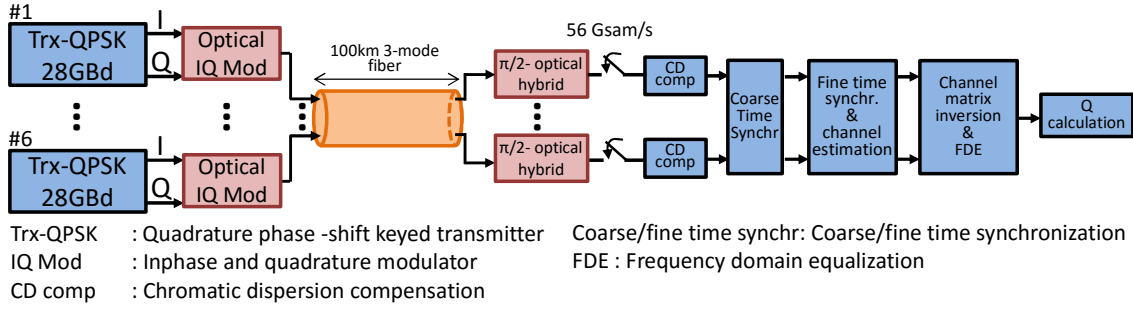

Fig. 1: Block diagram of the simulated SDM system.

averaging the Q-factor of the received 6 signals.

MIMO Channel Matrix and CIR Length

Orthogonality of the transmitted CAZAC sequences is ensured by choosing a sufficiently long length and using a different cyclical shifted version of the original sequence for each transmitted signal. Channel estimation is performed in the time domain at the receiver by cross-correlating the received signals with the training CAZAC sequences. Under proper selection of the CIR length, crosstalk and inter-symbol interference (ISI) due to mode coupling and DMD can be compensated for after equalization. In the simulations performed, however, we will study the receiver memory length required to ensure a Q-factor higher than 17dB by sweeping the value of the time-finite window length used for the computation of the cross-correlation. In Fig. 2, for example, we show a sample of the estimated CIR for the signal transmitted and detected in the mode LP_{01} for a coupling strength and DMD equal to -30dB/100m and 20ps/km, respectively, for 3 different designed receiver memory lengths (1.19ns, 0.93ns and 0.64ns) and the obtained

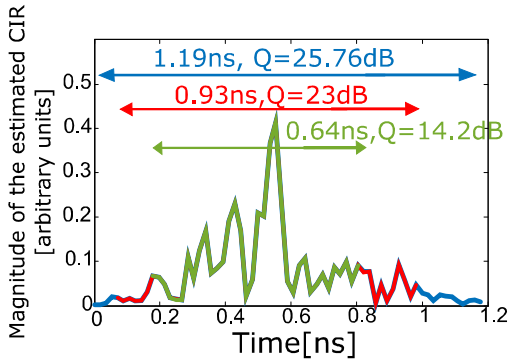

Fig. 2: Estimated $LP_{01}(\text{input})-LP_{01}(\text{output})$ CIR for each different designed memory length and corresponding Q factor value.

Q-factor values.

As expected, the Q factor increases with the value of the assumed CIR length. Since we are assuming noiseless conditions, we select the location of the time window which provides the CIR estimation with highest energy. The minimum receiver memory length to ensure that

the Q-factor is higher than 17dB is computed for a broad range of coupling strengths and DMD values. Moreover, since mode coupling in FMF occurs randomly, and therefore the effects of crosstalk and ISI on the performance are also of random nature, different realizations of the fibre are carried out in order to ensure statistically meaningful values.

Results

Fig. 3 shows the required number of taps for CIR estimation (num. taps(s)= memory length(s)/56Gsam/s) to ensure that $Q > 17\text{dB}$ when the coupling strength and the DMD are varied simultaneously for the conventional system, and using DMD management with 1, 4 and 25 segments. The memory length values shown are calculated as the average minimum value to achieve a Q-factor higher than 17dB.

In Fig. 3(a), DMD ranges from 0.1ps/km to 20ps/km, whilst XT is varied within -50dB/100m and 0dB/100m. The same trend can be observed for all the values of DMD: given a DMD value, the memory length required maintains constant for values of XT between -50dB/100m and -30dB/100m, and it then starts to decrease as the XT increases. Putting it in numbers, for a DMD equal to 10ps/km, a time window of around $1.07\text{ns} = 60/56\text{Gsam/s}$ would be required for coupling strengths between -50dB/100m and -30dB/100m, whilst we would need a time window of around $0.178\text{ns} = 10/56\text{Gsam/s}$ if mode coupling with a strength of 0dB/100m is introduced.

Figs. 3(b), (c) and (d) show the required receiver memory length for DMD values ranging from 0.1ps/km to 200ps/km, and XT ranging from -50dB/100m to 0dB/100m in the case DMD management is used with 1, 4 and 25 segments, respectively. We need to take into account that two driving forces take part. Firstly, the reduction of the DMD due to a higher coupling strength, and secondly the DMD compensation effectiveness, which decreases with segment length and coupling strength. It can be observed that a more efficient DMD compensation is achieved for a higher number of segments.

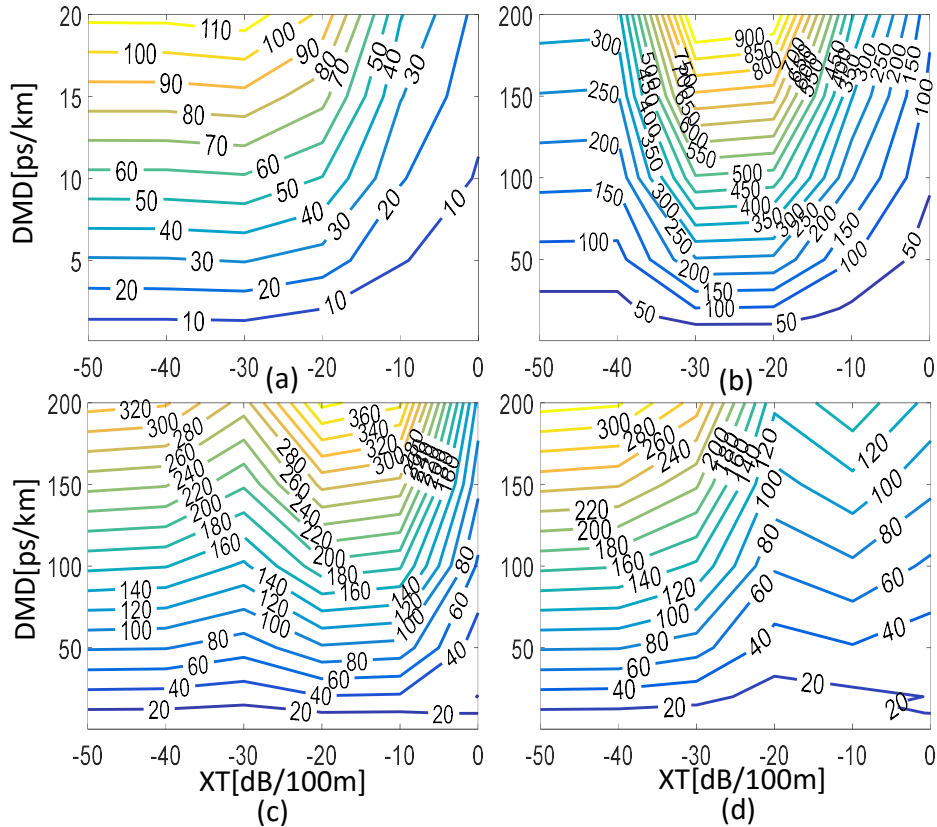

Fig. 3: Required number of taps to ensure that $Q > 17$ dB (a) no DMD compensation, and with DMD compensation using (b) 1 segment, (c) 4 segments, and (d) 25 segments.

Moreover, when 1 segment is used, the required number of taps for a given DMD value starts to increase for $XT = -40$ dB/100m, whilst such increase is observed for $XT = -30$ dB/100m and $XT = 0$ dB/100m when 4 and 25 segments are employed, respectively. For example, for $XT = -30$ dB/100m and a $DMD = 100$ ps/km, a memory length equals to 8.9 ns is needed for 1 segment, whilst a value of 2.5 ns would be required for 4 and 25 segments. For conventional FMF fibres, which operate in a coupling strength range from -40 dB/100m to -30 dB/100m, in order to fully take advantage of the DMD compensation, a compensation period of 25 km would be required. Finally, for the 3 cases studied with DMD compensation, there is a clearly observable intermediate XT region in which DMD compensation and mode coupling counteract one another, and after which the beneficial effect of mode coupling starts to be apparent. Such region occurs for higher values of XT as the number of segments is increased.

Conclusions

Effectiveness of DMD management under intermediate regime coupling has been observed for compensation period of 25 km. Performance results have also shown the efficiency of strong mode coupling to reduce the

time-window length required at the receiver DSP as long as a coupling strength higher than -30 dB/100m is introduced.

Acknowledgements

This work has been partially supported by the European Union (Grants 619732-INSPACE, 654809-HSPACE, 659950-INVENTION, and 627545-SOLAS), and by the EPSRC (Grant EP/L000091/1-PEACE).

References

- [1] S. Randel et al., "Mode-Multiplexed 6x20-GBd QPSK Transmission over 1200-km DMD-Compensated Few-Mode Fiber," Proc. OFC, PDP5C.5, Los Angeles (2012).
- [2] S. Ö. Arik, D. Askarov, and J. M. Kahn, "Adaptive Frequency-Domain Equalization in Mode-Division Multiplexing Systems," J. Lightwave Technol., Vol. **32**, no. 10, p. 1841 (2014).
- [3] K-P. Ho and J. M. Kahn, "Statistics of Group Delays in Multimode Fiber With Strong Mode Coupling," J. Lightwave Technol., vol. **29**, no. 21, p. 3119 (2011).
- [4] F. Ferreira, et al., "Nonlinear Semi-Analytical Model for Simulation of Few-Mode Fiber Transmission," Photon. Technol. Lett., vol. **24**, no. 4, p. 240 (2012).
- [5] F. Ferreira, et al., "Few-mode group-delays with intermediate coupling," Proc. ECOC, p. Th.1.6.1, Valencia (2015).
- [6] H. Minn, M. Zeng, and V. K. Bhargava., "On Timing Offset Estimation for OFDM Systems," IEEE Comm. Lett., Vol. **4**, No. 7, p. 242 (2000).