

# Comparison of centralised and distributed battery energy storage systems in LV distribution networks on operational optimisation and financial benefits

Zhi Qiao, Jin Yang

School of Engineering and Applied Science, Aston University, Aston, UK

E-mail: qiaoz@aston.ac.uk

Published in *The Journal of Engineering*; Received on 10th October 2017; Accepted on 3rd November 2017

**Abstract:** The integration of renewable energy sources and plug-in electric vehicles (PEVs) into the existing low-voltage (LV) distribution network at a high penetration level can cause reverse power flow, increased overall energy demand, network congestion, voltage rise/dip, transformer overloading and other operational issues. In this study, these potentially negative impacts caused by increasing penetration of distributed energy resources and PEVs are stochastically quantified based on a real practical 400 V distribution network as a case study. Battery energy storage (BES) is known to be a promising method for peak shaving and to provide network ancillary services. Two types of BES implementations aiming at distinctive charging and discharging targets without communication infrastructure or control centre are proposed and simulated. Optimisation results and potential financial profit of these two BES systems are compared and discussed in detail.

## 1 Introduction

Renewable energy sources (RESs) and plug-in electric vehicles (PEVs) can benefit domestic customers to reduce the electricity bill and incurred transportation expenses. Almost all of the small-scale RESs, i.e. photovoltaics (PVs), wind turbines, and PEVs are connected to the existing low-voltage (LV) distribution networks interfaced with power-electronic converters. The traditional distribution networks are designed based on unidirectional power flow and rated by the number of houses and the after diversity maximum demand (ADMD). In some of the network planners in the UK, 3 kW is a typical value used as ADMD for a three-bedroom domestic house. A small-scale single-phase rooftop PV can inject up to 16 A (3.68 kW) to the grid according to energy networks association (ENA) G83 engineering recommendation. Typical single-phase PEV charging rate is nearly the same as ADMD and most of them start charging after 3 pm [1] which coincide with the peak of domestic load. However, the increasing penetration of RESs and PEVs integrated into LV distribution networks can cause several technical challenges, such as bi-directional power flow, increased overall power demand, network thermal issue/congestion, voltage rise/dip, phase unbalance, poor power quality [2–6]. Potential solutions are suggested in the literature including the time of use (TOU) pricing scheme, electric vehicle (EV) charging management, demand side management, battery energy storage (BES), vehicle to grid and so on. A real-time EV charging management control algorithm is introduced in [6] which can mitigate some of the EV impacts on the grid. Nevertheless, most of these approaches require a central controller and communication infrastructure to collect real-time network and PEV charging states which need large capital investment.

BES has become a crucial element in the utility grid for its flexible charging/discharging capability. For the domestic user, a small size BES can be used to collect unconsumed electricity generated from PV or charge during an off-peak time when the price of electricity is low as a reserve for peak time. Although feed-in tariff [7] pays for the exported electricity energy, the price is still lower than the electricity price from the utility grid. The purpose of this

investment is to utilise the power generated from RES. On the other hand, distribution network operators (DNOs) prefer to apply BES for peak shaving, frequency regulation, and other operational optimisation targets. However, both BES configurations can mitigate, or partly mitigate the negative impacts aforementioned and improve the network robustness, intentionally or unintentionally. Control algorithms, management strategies, sizing and locating of BES are reported in [8, 9]. It is recognised that there are few technical barriers existing to impede widely adopting BES to LV distribution network. However, a technical and financial comparison is required to find an optimal solution from either centralised BES system or a series of distributed BESs in a practical LV network for different installation purposes.

Unlike most of the RESs and PEVs in the LV distribution network, which are owned by customers, BES can be installed by either DNOs or individual customers. BES system (BESS) owned by DNOs is more likely to be a centralised battery installed at the secondary-side of distribution transformers for peak shaving. Meanwhile, a series of distributed small-scale batteries can be installed at each dwelling owned by individual customers. These two distinctly different configurations are shown in Fig. 1, where the locations of batteries and radial network topologies are illustrated.

For customers, the ultimate goal of owning a BES is to store extra electricity generated from PV during the daytime, instead of feeding into the grid, since the feed-in rate is about one-third of the average electricity price (UK). Another function is to charge the BES during load off-peak times when the price of electricity is low, and discharge the stored energy during load peak evening time [10]. In contrast, DNO may prefer to shave the peak load and maintain other operational constraints to postpone substantial network reinforcement [11]. Both configurations will consider optimisation algorithms to utilise the battery capacity, justify the initial capital investment, and maintain financial profits during the expected lifespan of BES.

In this paper, a representative practical 400 V LV distribution network in the UK is modelled and used for time-series simulation, with validated domestic load, PEV charging, and photovoltaics

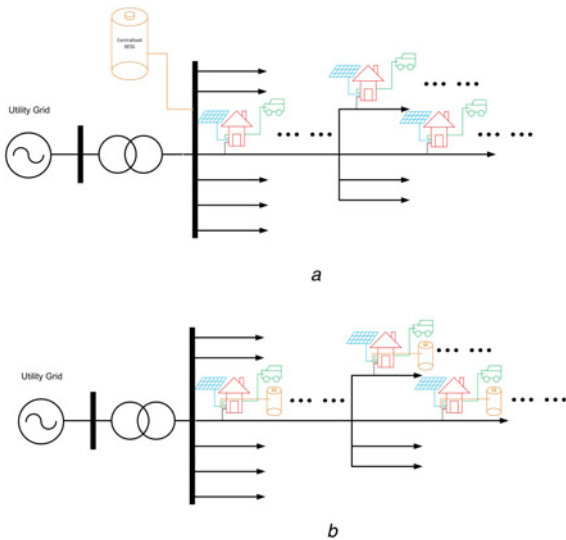

**Fig. 1** Illustrative topologies of network integrated with  
*a* Centralised BES owned by a DNO  
*b* Distributed BES owned by customers

generation profiles detailed in Section 2. In Section 3, with increasing penetration levels of PV generation and PEVs, transformer overloading issue is quantified. Charging and discharging algorithms for both BESS configuration are identified according to their basic profits in Sections 4 and 5, respectively. In Section 4, a comparison of these two BESS configurations from both technical and financial aspects are presented and discussed in detail. The conclusion is drawn in Section 7.

## 2 Modelling

### 2.1 Network

A real practical 400 V distribution network serving 292 domestic houses supplied from grid via a 500 kVA 11 kV/0.4 kV step down transformer. Single-line diagram of this network is shown in Fig. 2. The network is simulated using OpenDSS for power flow calculations and controlled by MATLAB commands for optimisation.

### 2.2 Domestic load

The overall power usage of this network is monitored at the secondary side by a local DNO. Due to the availability of load data, the

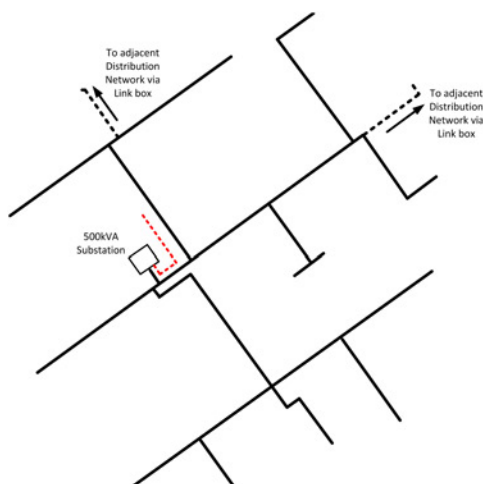

**Fig. 2** Geographical diagram of the simulated network

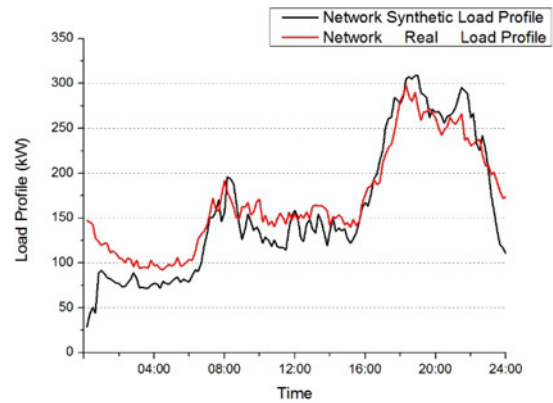

**Fig. 3** Comparison between average accumulated synthetic load profile generated with measured data at the substation in 10-min resolution

measured data is given in 10 min resolution. It is not representative to simply divide the overall usage by the number of customers. Therefore, a more detailed domestic electricity usage model, up to 1-min resolution introduced in [12], is adopted in this study to better simulate the individual power consumption behaviour. All houses are modelled as non-electric central heating residential houses (i.e. gas heating available in the dwelling). Two hundred and ninety-two independent domestic customers' load profiles on a weekday are created and correlated with the measured overall load profile. The average accumulated synthetic load profile before power flow calculation in 10 min resolution is compared with the measured data at the substation for validation, as shown in Fig. 3.

In Fig. 3, it shows that the accumulated artificial load profile has high similarity with the load data measured at substation hence customer load profiles are validated as a close representation of the actual load level.

### 2.3 PEV model

The PEVs simulated in this paper are considered as Nissan LEAF with 24 kWh battery capacity and 3.6 kW charging rating. The probability distribution function presented in [1] is applied to create 292 individual PEV charging profiles. Two examples, charging profiles are shown in Fig. 4. The detailed process of the profile generation can be seen in [13].

In Fig. 4, Example 1 indicates that a PEV charges twice a day – first charging starts from 9:00 with initial state of charge (SOC) of 9/12 and charged for 40 min to 9:40 with final SOC of 10/12; second connection starts at 22:15 with initial SOC of 8/12 and charged for 160 min to 0:55 next day to be fully charged (i.e. SOC is 12/12). Another example is only one connection in a day

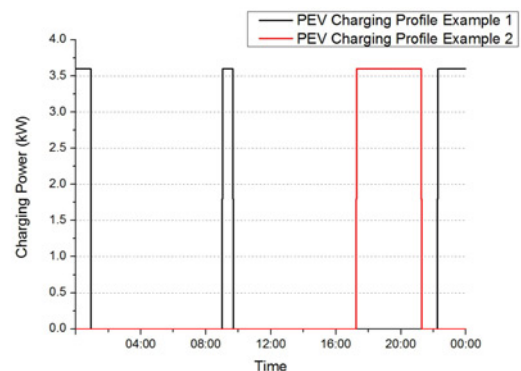

**Fig. 4** Two examples of charging profiles

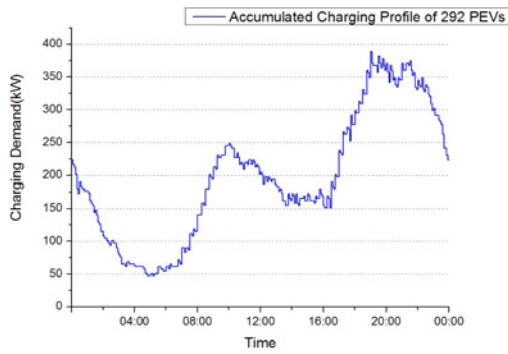

Fig. 5 Accumulated charging profile of 292 PEVs

starts from 17:15 with final SOC of 6/12 and charged for 240 min till 21:15 to be fully charged (i.e. SOC is 12/12).

Fig. 5 shows the accumulated charging profile of 292 PEVs if it is assumed that all houses have PEV facilities.

### 2.4 PV model

A typical solar radiation and temperature dataset are used in this section to simulate the PV power generation by each house. This data is within 15 min resolution. All the PV DERs installed are considered as a 3.5 kW rooftop solar panel. PV generation profile is modelled as shown in Fig. 6.

### 2.5 Battery model

Simplified centralised and distributed BES models are used to simulate basic performances of BES systems.

Each set of centralised BES contains a 50 kW/100 kWh sodium nickel battery and a 100 kVA rectifier/inverter unit. The overall efficiency of this type of battery is set as 85% as a usual value. The initial SOC is considered as 0 kWh, i.e. fully discharged.

A 3 kW/4.8 kWh lead acid battery is used for each house who has a PV installed and connected in this study. Again the overall battery efficiency is assumed as 85% of it charged power. An initial SOC of 0 kWh for each battery is assumed.

## 3 Impact quantification

This section illustrates the diversity of transformer overload issues resulting from uncontrolled PEV charging and PV generation on the object distribution network. PEV and PV connections at varying percentage combinations are investigated to quantify possible thermal issues at the transformer. By time-series simulation, the maximum power demand and minimum demand/maximum reverse power are recorded, as shown in Figs. 7 and 8.

When the EV penetration level is over 50%, i.e. there are 146 PEVs installed and charging in the network, the maximum

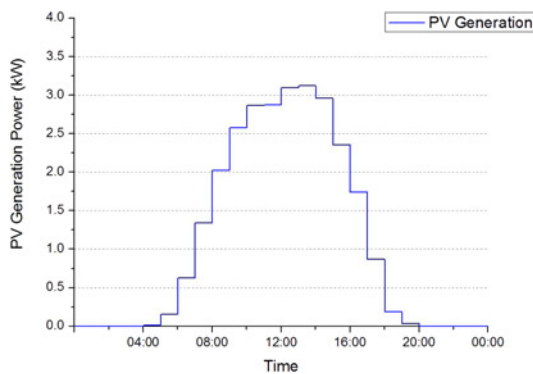

Fig. 6 PV power generation example

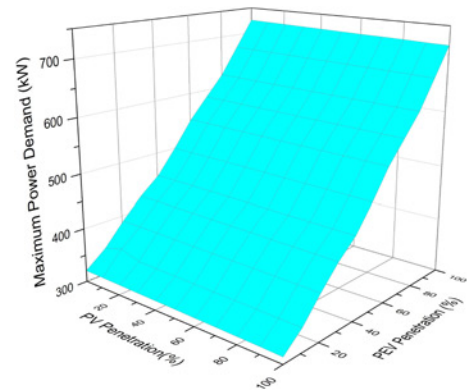

Fig. 7 Maximum power demand at varying PEV and PV penetration combinations

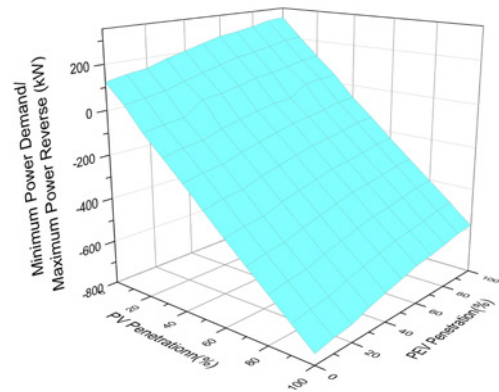

Fig. 8 Minimum demand/maximum reverse power at varying PEV and PV penetration combinations

demand will be greater than the rated capacity of the 11 kV/0.4 kV transformer which will cause thermal issues and deteriorated ageing. When the PV connections are over 80% of all houses, it is possible that the generation during the day exceeds the thermal constraint too. Voltage rise/dip and network congestion are also recorded from this simulation. Three phase unbalance happened in a short period since the EV connection is allocated stochastically.

A certain PEV and PV combination is chosen to explain the suggested method. When the PEV penetration is 90% and PV penetration is 90%, the power consumption (positive)/generation (negative) at the transformer is shown in Fig. 9.

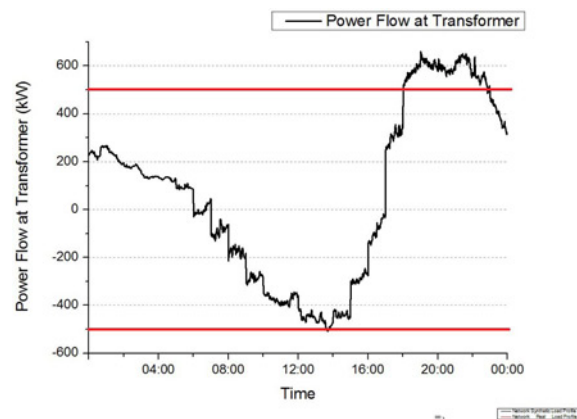

Fig. 9 Power at transformer when PEV penetration is 90% and PV penetration is 90%

The thermal issue happens during the mid-day when all the PV generation at approximately rated power, and load peak-time from 18:00 to 23:00 in the evening. Voltage rise and cable congestion are observed which will be discussed in the future. However, compared with thermal issues they are not the main constraints.

#### 4 Charging/discharging control and sizing of a centralised BESS

In this section, one centralised or a series of distributed BESS are used to collect the reverse power flow and discharge during peak-time. The centralised battery energy storage is installed on the secondary side of the 11 kV/0.4 kV transformer. The suitable size and optimal charging/discharging trigger are identified during simulation.

The battery charges when there is reverse power measured (negative value) at substation over a threshold value, and discharges during load peak time, when the overall power demand at the substation goes over its thermal limit. Once the energy stored in the battery is used up, the network will need to be fully supplied from the utility grid.

A series of simulations indicate that two sets of this BES are required to partly mitigate the impacts, meanwhile, the charging threshold is  $-415$  kW at reverse power flow and the discharging threshold is  $530$  kW when the network demand is high. The power flow simulations indicate that a  $100$  kW/ $200$  kWh BES can partly mitigate the overload at the transformer shown in Fig. 10.

If another set of  $100$  kW/ $200$  kWh BES is also available at the secondary side of the substation transformer, a better optimisation result can be yielded as shown in Fig. 11.

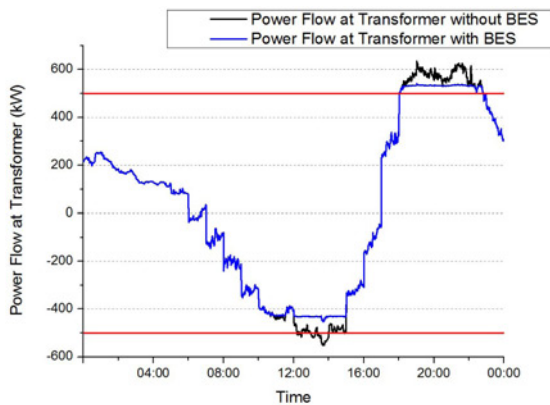

Fig. 10 Power flow result at transformer with a set of centralised 100 kW/200 kWh BES

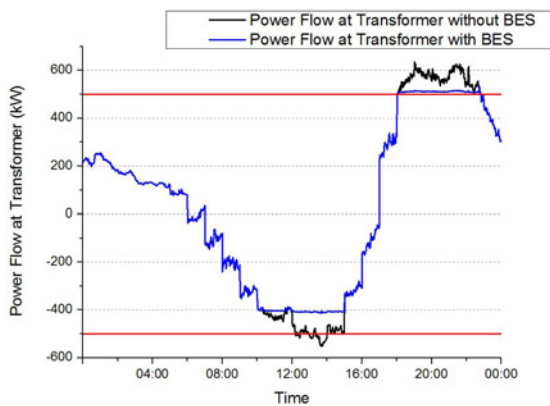

Fig. 11 Power flow result with two sets of centralised 100 kW/200 kWh BES

#### 5 Charging/discharging control of distributed BESSs

The assumption made here is that all the houses installing an RES system (PV) also implement a BES system to locally store part of the energy that was used to be feed into the utility grid, and get paid from feed-in tariff and reduced utility bills by the BES supply to any domestic electricity demand or EV charging.

Among 292 domestic customers, 90% of them install a PV system, thus 262 distributed 3 kW/4.8 kWh BESSs are considered here to be installed and connected to the network, where their charging and discharging operations are determined by the control and management of local energy demands.

A distributed BES system for each individual houses can store energy generated from their own rooftop PV which can be used during peak-time. Since the feed-in tariff scheme rewarding a lower price for the clean energy compared with the price of power supplied by the utility companies. In this trial, only those customers with both EV and PV are considered to install a small BES system. Overall similar effects can be obtained that by adding locally controlled distributed BESS, negative thermal and voltage effects can be reduced.

According to the simulation results obtained as shown in Fig. 12, these distributed BESS can also achieve a similar optimisation target. However, these aggregated distributed BES can be equivalent to a  $786$  kW/ $1258$  kWh centralised BESS, which shows distributed control has an advantageous effect.

#### 6 Comparison and discussion

Both the two methods can mitigate the overloading problem in the distribution transformer, without substantial measurement or communication requirements of the grid.

As reported in a market search, a 210 kWh tesla battery cost about £60 k including the cost of the inverter and installation. While the benefit of a centralised BES on a network is to postpone sensational network reinforcement. However, the actual benefits for DNO are hard to be estimated financially. For example, other ancillary services provided by BESS, such as frequency regulation can be rewarding.

For the distributed BES, a 4.8 kWh home solar battery cost about £5 k including installation. The expense of installation witnessed by a local DNO is not taken into account here. The up-to-date feed-in tariff rate is 4.14 p/kWh for a standard solar PV receiving a higher rate [7]. The average electricity market price from suppliers is 15.2 p/kWh (peak rate) and 7.1 p/kWh (off-peak rate). Off peak period starts from 23:30 till 8:00 the next day in Midland Area in the UK.

With this information, the benefits of customers can simply be calculated according to the feed-in rate and economy seven times of use electricity price, as presented in Table 1.

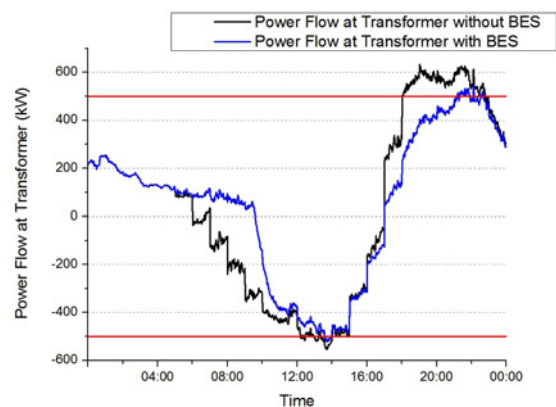

Fig. 12 Power flow result at transformer with 262 distributed 3 kW/4.8 kWh BESSs

**Table 1** Comparison of benefit before and after the installation of BES

	Before BES installation	After BES installation
Electricity cost/house/day	£1.49	£1.24

## 7 Conclusion

In this paper, results show that both centralised and distributed BES can mitigate the network thermal and voltage issues. Specifically, simulation results show that the customer-owned distributed BESSs can support the voltage regulation, power loss reduction, and peak shaving of the network, but with limited effects. While as designed, DNO-owned centralised BESS mainly plays a significant role in peak shaving.

Charging and discharging algorithms for centralised and distributed BESS are discussed and optimised, respectively. The outcome of the proposed optimisation can be applied to maximise the benefits (DNO – mainly technical; customers – mainly financial), considering extending the lifespan of BESSs. Different effects on the network's operation are also identified for these distinctive energy management algorithms of BESS. Additional information can be considered is the Smart Metering data, which provide comprehensive information (bi-directional electricity and tariffs) for customers to manage the usage of electricity according to the TOU price scheme, in order to reduce electricity costs. Investment model and analysis will be carried out based on existing UK feed-in-tariff rates, Economy seven TOU scheme, BESS capital costs, installation and maintenance costs and so on. A quantified financial comparison of optimised centralised and distributed BESSs will be conducted to balance the profits of both sides as shown in details.

It is also worth noting that BESSs provided and maintained by third party companies under a business contract with the customer and DNO, supported by the government could be an alternative solution to achieve the utilisation of renewable energy and electrical equipment in networks. Another possible situation is that the BESS can charge automatically according to the next time-stamp

forecast weather condition during the off-peak time to better utilise system installed.

## 8 References

- [1] Quirós-Tortós J., Ochoa L.F., Lees B.: 'A statistical analysis of EV charging behavior in the UK'. Innovative Smart Grid Technologies Latin America (ISGT LATAM), 2015, 2015, pp. 445–449
- [2] Fasina E.T., Hassan A.S., Cipcigan L.M.: 'Impact of Localised Energy Resources on electric power distribution systems'. 2015 50th Int. Universities Power Engineering Conf. (UPEC), 2015, pp. 1–5
- [3] Awadallah M.A., Singh B.N., Venkatesh B.: 'Impact of EV charger load on distribution network capacity: a case study in Toronto', *Can. J. Electr. Comput. Eng.*, 2016, **39**, pp. 268–273
- [4] Vicini R., Micheloud O., Kumar H., *ET AL.*: 'Transformer and home energy management systems to lessen electrical vehicle impact on the grid', *IET Gener. Transm. Distrib.*, 2012, **6**, pp. 1202–1208
- [5] Dubey A., Santoso S.: 'Electric vehicle charging on residential distribution systems: impacts and mitigations', *IEEE Access*, 2015, **3**, pp. 1871–1893
- [6] Quirós-Tortós J., Ochoa L.F., Alnaser S.W., *ET AL.*: 'Control of EV charging points for thermal and voltage management of LV networks', *IEEE Trans. Power Syst.*, 2016, **31**, pp. 3028–3039
- [7] O. o. G. a. E. Markets.: 'Feed-in Tariffs (FIT)', 2010. Available at <https://www.ofgem.gov.uk/environmental-programmes/fit>
- [8] Wang Y., Lin X., Pedram M.: 'Adaptive control for energy storage systems in households with photovoltaic modules', *IEEE Trans. Smart Grid*, 2014, **5**, pp. 992–1001
- [9] Bass R.B., Carr J., Aguilar J., *ET AL.*: 'Determining the power and energy capacities of a battery energy storage system to accommodate high photovoltaic penetration on a distribution feeder', *IEEE Power Energy Technol. Syst. J.*, 2016, **3**, pp. 119–127
- [10] Karami H., Sanjari M.J., Hosseinian S.H., *ET AL.*: 'An optimal dispatch algorithm for managing residential distributed energy resources', *IEEE Trans. Smart Grid*, 2014, **5**, pp. 2360–2367
- [11] Shen X., Shahidehpour M., Han Y., *ET AL.*: 'Expansion planning of active distribution networks with centralized and distributed energy storage systems', *IEEE Trans. Sustain. Energy*, 2017, **8**, pp. 126–134
- [12] Richardson I., Thomson M., Infield D., *ET AL.*: 'Domestic electricity use: a high-resolution energy demand model', *Energy Build.*, 2010, **42**, pp. 1878–1887
- [13] Qiao Z., Yang J.: 'Low-voltage distribution network reconfiguration considering high penetration of electric vehicles - A UK case study'. 2016 IEEE Int. Conf. Renewable Energy Research and Applications (ICRERA), 2016, pp. 708–713