

Loughborough University Institutional Repository

Low cost laboratory micro-grid hardware and control for electrical power systems teaching

This item was submitted to Loughborough University's Institutional Repository by the/an author.

Citation: TITMUS, P., STRICKLAND, D. and CROSS, A.M., 2017. Low cost laboratory micro-grid hardware and control for electrical power systems teaching. 19th European Conference on Power Electronics and Applications (EPE'17 ECCE Europe), Warsaw, Poland, 11th-14th September 2017.

Additional Information:

- © 2017 IEEE. Personal use of this material is permitted. Permission from IEEE must be obtained for all other uses, in any current or future media, including reprinting/republishing this material for advertising or promotional purposes, creating new collective works, for resale or redistribution to servers or lists, or reuse of any copyrighted component of this work in other works.

Metadata Record: <https://dspace.lboro.ac.uk/2134/28162>

Version: Accepted for publication

Publisher: IEEE © assigned jointly to the European Power Electronics and Drives Association & the Institute of Electrical and Electronics Engineers (IEEE)

Please cite the published version.

Low Cost Laboratory Micro-grid Hardware and Control for Electrical Power Systems Teaching

P. Titmus
ASTON UNIVERSITY
PEMPS Group,
Birmingham, United Kingdom,
Tel.: +44 / (0) 121 204 3615
E-Mail:p.titmus@aston.ac.uk

D. Strickland, A Cross
LOUGHBOROUGH UNIVERSITY
CREST
Loughborough, United Kingdom
(0) 7891806767
d.strickland@lboro.ac.uk, a.cross@lboro.ac.uk

Keywords

«Power System Control», «Power Engineering», «Microgrids», «stability», «supervised learning»

Abstract

There is a growing trend within education establishments to teach electrical power system theory within lectures and back this up with software simulation laboratory sessions. This allows the courses to be taught at a lower cost than if real hardware was implemented. However, the students that are graduating from these programs are missing out on the opportunity to learn about real equipment and issues such as health and safety of voltages above 50V, mismatching component sizes and accuracy. Bespoke electrical power systems teaching equipment is expensive to buy. This paper details a low cost hardware setup that can be used to enforce electrical power system theory. The proposed equipment employs real off-the shelf equipment with some interfacing units which can be reproduced by laboratory technicians to enhance the student learning experience by offering students experience of real machines operating on an electrical power systems network.

Introduction

The education of students in electrical power engineering has been undergoing many changes over the last twenty years. In the UK, for example, this has been impacted by several major changes;

1) Privatisation of the electricity industry

This has resulted in a significant drop in the number of students studying Power Engineering at BEng level or above as industrial research funding to university departments has dropped and the insecurity around long term job prospects has made the courses less attractive to students. This has resulted in the closure of many groups with the UK.

2) Pressure to reduce costs

Equipment relating to Power Engineering is typically large and operates at high voltage. This means it is expensive to maintain and takes up a lot of space. Consequently many departments have chosen to remove the equipment in favor of more simulation based activities as a way of re-enforcing taught learning.

3) Current challenges in a smart grid context

Research and development into smart grids through Distribution Network Operators (DNO's) has seen progress in areas such as dynamic asset rating, power electronic development and energy storage. The progress needs to be aligned to the need to update teaching and learning to reflect good practice. This results in a risk of obsolescence of Electrical Power Laboratory equipment.

To summarize, there are less departments teaching Electrical Power with less resources in the face of a changing system. The pressure to move from hardware to simulation based activities therefore seems a sensible option. However, a total move away from hardware to simulation is not without risks to the development of a well-rounded engineer ready for employment in industry. Key factors that need to be considered include;

1) Confidence with hardware

A trend towards bespoke teaching and learning equipment and health and safety legislation has resulted in laboratory rigs that are built around the ability to lay a lab out on the bench, run the lab and put it away with the minimal amount of time, while being clear for the students to follow on a lab sheet. Wiring between pieces of equipment tends to be set up by the laboratory supervisor. This is dissimilar to R&D projects run within industry where equipment may not be well documented and wiring connections, signal conditioning, EMI, power supply systems may all be an issues.

2) Understanding Health and Safety Issues

The IET wiring regulations classify low voltage at 50V. Anything above this voltage is careful shrouded to reduce risk. This leaves a mismatch between academia and industry. In academia, health and safety is considered in advance by module and program leaders and the requirement of students to understand health and safety issues as a practical issue that they need to own is largely missing. The students therefore, do not have familiarity with the risks of dealing with voltages of levels that could be lethal. This is in contrast to the electricity industry where live working above these voltages is common practice for achieving good availability of supply. Within publications there is recommendation that live working be covered within Universities for graduates [1].

3) Appreciating the difference between “ideal” and “real life”

Equipment in the real world does not behave in the same way as equipment that is simulated. Issues such as mismatching component sizes, leakage, instrumentation accuracy, timing delays, transient conditions, EMC and EMI issues are largely neglected as an “ideal” system is considered in simulation.

Therefore real life learning can be lost if practical hardware is not considered.

The reasons for allowing the students to undertake laboratory experiments to support learning in the context of what would be found in industry therefore offers valuable learning opportunities that are missed if simulations or contrived laboratory equipment is used. However, the need to develop fit for purpose laboratory equipment leads to issues of cost and functionality. To overcome these issues, some specific examples of real life learning using hardware has been published within power systems teaching. An example is the practical use of power quality equipment [2]. This paper builds on this concept and describes a low cost laboratory micro-grid set up which operates at 400V as a means of teaching groups of up to 14 students. The practical issues around controlling and operating a grid system and allowing re-enforcement of traditional practical theory on voltage and frequency control, AVR operation and stability are covered as part of the experimental setup described.

The laboratory experiment described here is also similar in nature to that in Reference [3] which used old machines equipment to provide the base hardware for a similar setup. Reference [4] also has a hardware based solution that consists of a set of test beds that can be linked together to form a microgrid. In commonality to the work described in this paper they implement a labview based graphical interface with DAQ and adaptable hardware setup. However the hardware and control strategy in both these papers is not specified in sufficient detail to be replicated easily by other institutions and the machines appear to be either existing or custom built rather than low cost and readily available off the shelf machines. This paper specifies the components required in significantly more detail such that the equipment can be put together with very little prior knowledge from its component parts and a full costing of the setup can be appreciated.

This setup and that in reference [3] and [5] is in contrast to other University developed micro-grids which are primarily aimed at research purposes [6] and/or don't include traditional generation needed for full understanding of a current day grid system [4,7-10] and therefore lack the ability to be easily used by groups of students for teaching purposes. There are some teaching based hardware setups described in literature but these focus primarily on renewable systems and ignore traditional generation with forms the back bone of the system [11] or have a flexible machine bed where different machines can be used but lack the number to make a representative grid system [12,13]. These may also be in a more traditional format of one machine type per experiment [14]. The setup proposed in this project can be used for both traditional taught laboratory experiments or used to within a more project based learning approach (PBL). A PBL approach has been used successfully with software based power systems learning [15] and is easily adapted to a hardware approach.

The laboratory setup includes the ability to integrate smart grid functionality such as power electronic equipment to help learning on new techniques. This paper looks at the hardware setup, the control systems needed, summarises the laboratory experiments and looks at student response.

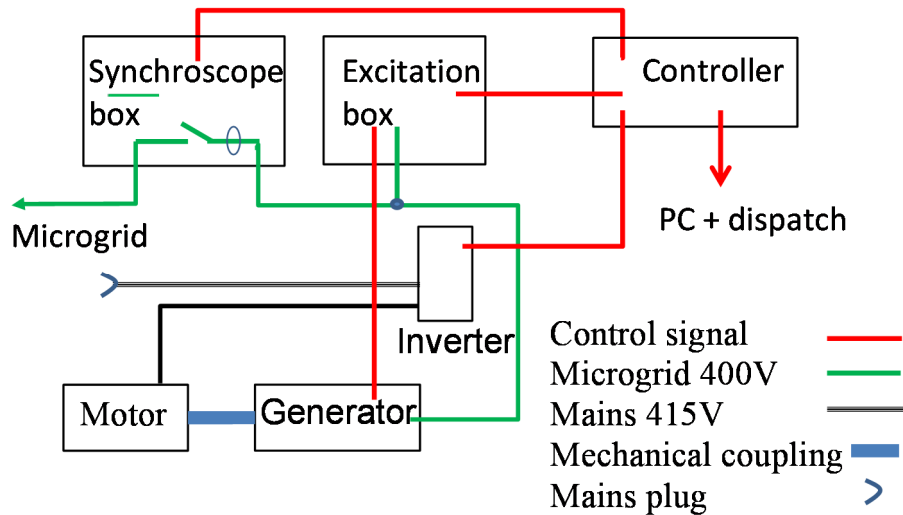

Fig. 3 Schematic of Microgrid generator interconnection

Table I Bill of material for each generator (x4)

Component	Supplier	Cost
Siemens Drive system Including Motor (part no)	HMK	£1931
3 phase synchronous generator (part no)	Electron	£668
Mounting and coupling guard	RPS Engineering	£303
cRIO-9014 controller + 2 x 4ch AI module (NI-9215) + 1 x 8ch AI module (NI-9201) + 1 x 4ch AI module (NI-9219) + 1 x 4 ch AO module (NI-9263) + 2 x 4ch RO module (NI-9481)	National Instruments	£311
Compact Rio	National Instruments	£1500
Excitation unit		£197
Synchronizing and current monitoring Unit		£246
Line inductor and Sensor Circuit Unit		£251
Laptop (Lenovo)	Getech	£450
Total cost		£5857

A photograph and schematic of the excitation system are shown in Fig. 4. The bill of materials of each excitation unit costed above is shown in Table I.

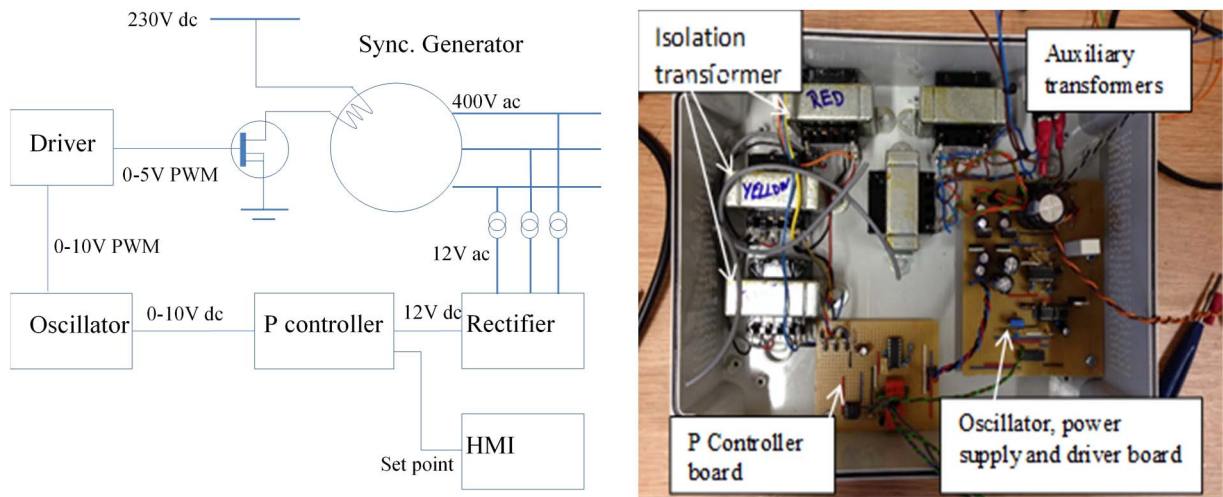

Fig. 4 Excitation circuit

Table II: Bill of material for each excitation unit

Component	Description
TL084	Oscillator from a discrete op Amp
LM311	Level shifts input to oscillator
IR2102	Gate driver chip
	230/12 V Isolation transformer
IN4001	Rectifier from discrete components
IXP36N30P	FET
TL084	Buffer/Comparator/ P controller
Component	Description

To connect the micro-grid each generator needs to be synchronized in turn. A circuit representation of this sub system is shown in Fig. 5, with a hardware layout.

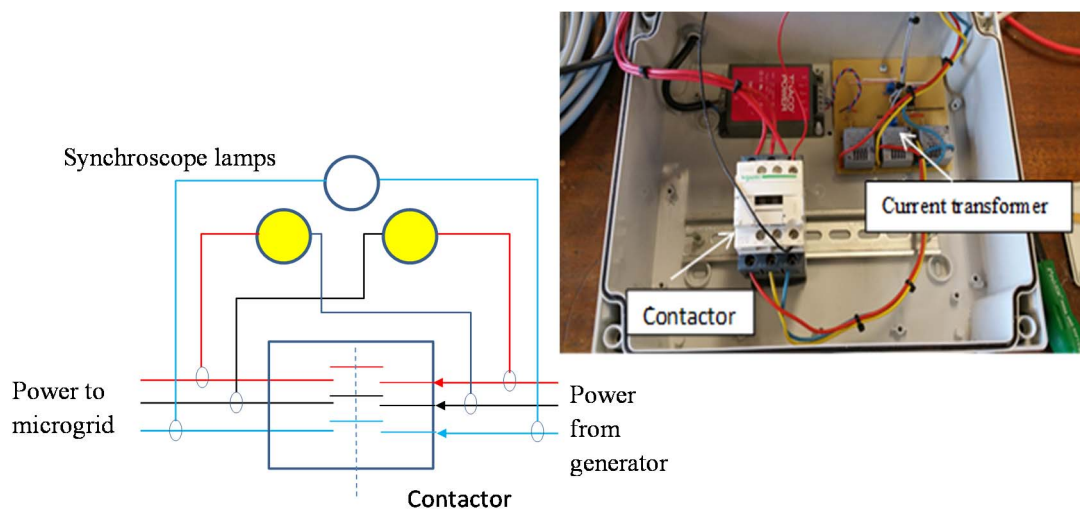

Fig. 5 Synchroscope box

Laboratory Micro Grid Control

To enable the students to control the micro grid the following functionality has to be made available:

1. Control of the prime mover (motor through the inverter)
2. Control of generator speed through governor action (and system frequency)
3. Control of generator output voltage through AVR action
4. Control of the contactor to connect the generator to micro-grid

This is achieved through an HMI Interface as shown in Fig. 6. which shows the on/off controls (toggle switches) and setpoints (in white) that the student has access to along with feedback of measured parameters. Fig. 7 shows the control behind the prime mover circuit.

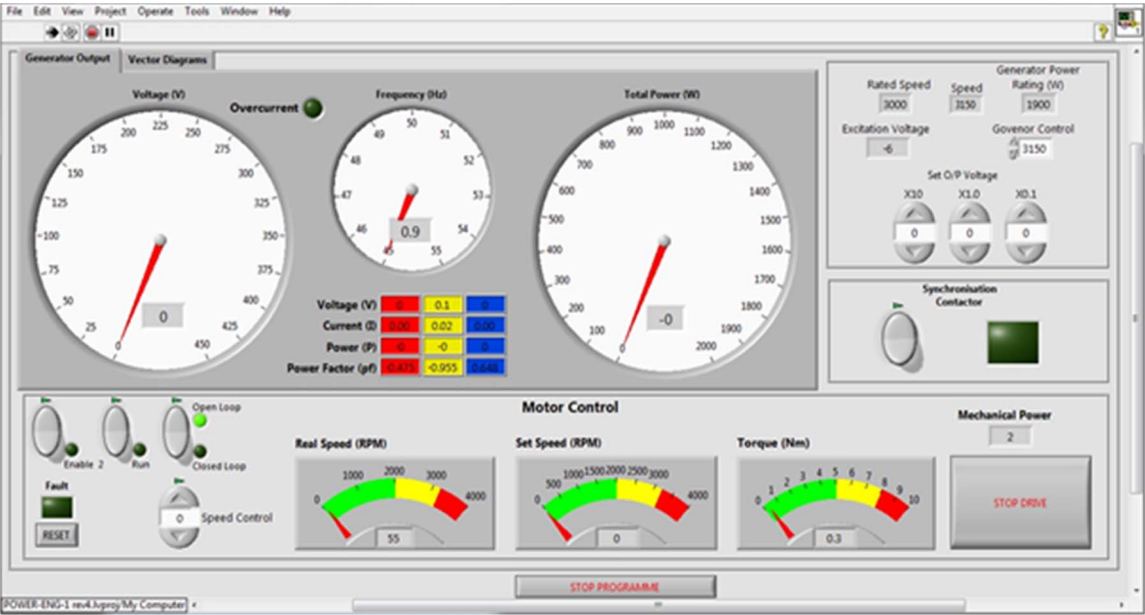

Fig. 6 Student HMI Interfaces

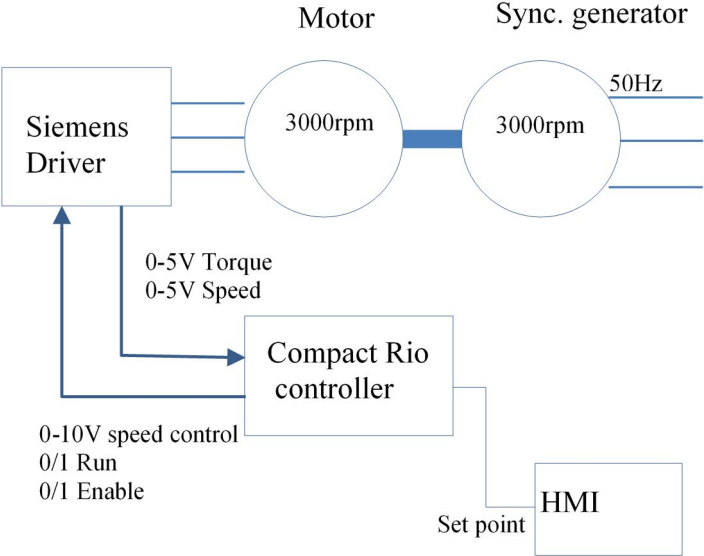

Fig. 7 Schematic of prime mover circuit

The student has the option to set a fixed speed (open loop control) or to operate the microgrid in frequency droop control (closed loop) by changing the governor setting as described below.

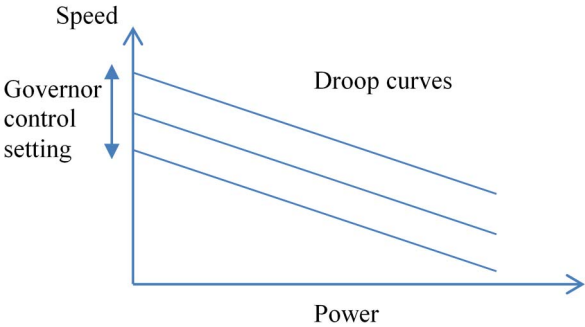

Fig. 8 Governor control setting and HMI screen of system

The droop characteristic interfaces to the drive as shown in the schematic in Fig. 9. Where C_1 is the conversion of speed setpoint from speed to drive input voltage. C_2 is the conversion from output voltage to measured radians. C_3 is the conversion of output voltage to measured torque. M is the gradient of the droop curve from Fig. 8. and the Governor control setpoint is the control variable equal to where the droop curve crosses the y axis in Fig. 9.

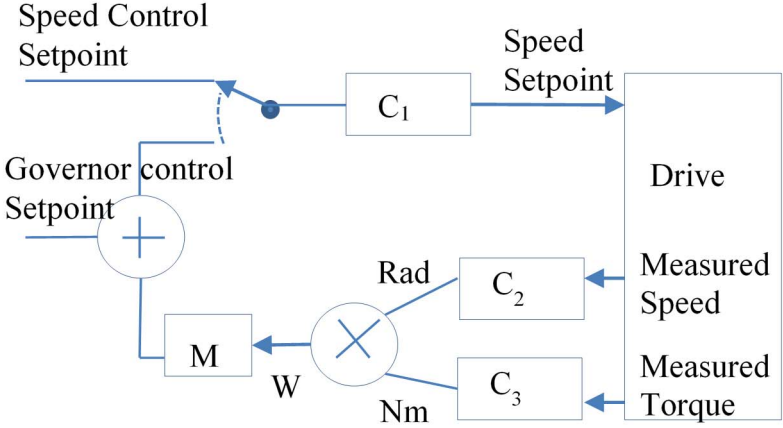

Fig. 9 Governor control schematic

The contactor is on open loop control and it is down to the students to determine when to close the contactor based on the synchroscope lamps. If the students close the contactor when the generators on the system are not synchronized then the system will trip off and they will need to restart the grid.

Laboratory Micro-experiments

The students need to be able to perform tests to assist with taught learning principles. This includes the ability to:

- 1. Start/Run and Stop a generator
- 2. Analyse three phase measurements and associated vector diagrams
- 3. Connect a generator to a grid

4. Change the load on the grid including implementing load imbalance and analysing the circuit
5. Change the voltage control between open and closed loop to show the effect of the AVR
6. Change the AVR setting to adjust the sending end voltage and show that the voltage at the load changes. Analyse the change in P and Q through the circuit.
7. Change the governor settings to allow load to be shared between generators to demonstrate the principle of frequency control
8. Understand issues which impact grid stability and how to black start a system following a blackout

This allows the students to see in a practical environment how a generator works and synchronizes to the grid while also examining stability, frequency and voltage control. The student is then encouraged to explore ideas such as;

- Where did the micro-grid behave as expected and where did it vary from expected?
- What differences are there between the micro-grid and a proper grid system in terms of operation and control?

The lab can be run as either a PBL type exercise with a high level aim or as a more constrained laboratory exercise.

Experiment evaluation

A technique, previously used by [16] to assess the effectiveness of the micorgrid as a means to enhance teaching was undertaken. As part of this the students were asked to complete a table with 6 questions as shown in Table III and grade these on a scale of 1-5 where 5 means effective. The students were also asked to provide comments.

Table III: Evaluation Table

Lab evaluation	Rating 1(low) to 5(high)	Comments and suggestions
1. Effectiveness of Lab experiments in promoting understanding		
2. Effectiveness of Lab experiments in developing analysis skills		
3. Effectiveness of Lab experiments in developing team work		
4. Effectiveness of Lab sheet, descriptions, labview HMI and other supportive material		
5. Effectiveness of equipment needed to complete lab		
6. Relevance to course objectives		

Data from the laboratory was collected from two groups – a small group of 5 students and a larger group of 13 students. The results were collated and are shown in Fig. 10.

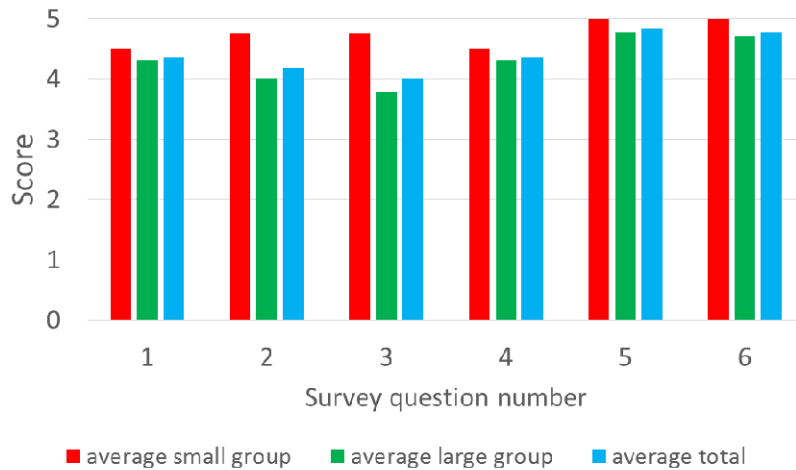

Fig. 10 Student survey results

A list of student comments about the lab is included below

Stimulating, a hands on approach is extremely effective at furthering understanding of the module

A good Lab, a results pro-forma would speed up the session

Handout was clear, aid and support by staff members was good

Fantastic lab, really enjoyed it and relevant to theory learned. Definitely recommend

Supplementary material to view beforehand so gain understanding before the lab would be useful and aid understanding

Relevant to business/roles helps support c/w from earlier in year on synchronising to a grid

Noisy equipment. Showed the group a clearer way of frequency control

Microgrid experiment brought all the learning together over two years of this course

I found this lab very interesting and helped develop some of the topics we already learnt but not yet confident on

Understanding isn't 100% maybe needed longer to understand and take in the information

In particular micro-grid lab helped understanding. Some labs such as the transformer labs can be confusing as the lab sheets aren't clear.

The students mostly felt that this lab was good in helping their base understanding and was an effective learning tool. In particular they felt the equipment was fit for purpose and the the lab helped them fulfil their course aims and objectives.

Conclusion

This paper describes a hardware set up of a micro-grid along with the key control necessary for implementation to allow a low cost experimental setup to be developed for teaching purposes. Although this setup deals primarily with voltage and frequency control issues including stability and black start, this setup can be easily adapted to include power electronic converters, other forms of generation and protection functionality. The results showed that students in both small and larger groups appreciated this as a tool towards developing their understanding. However, the students in the larger group found it more difficult to undertake a group activity because of the larger number of people.

References

- [1] M. Portillo, "For a better understanding of Live Working", Live Maintenance (ICOLIM), 2014 11th International Conference on
- [2] J. Attia; P. Cofie; Wei-Jen Lee; M. Ladd, "Power Quality and Reliability of University Campus Equipment - Industry and Academic Partnership Program", Frontiers in Education, 2005. FIE '05. Proceedings 35th Annual Conference, Pages: T4H - T4H
- [3] Rasheduzzaman, M.; Chowdhury, B.H.; Bhaskara, S., "Converting an Old Machines Lab Into a Functioning Power Network With a Microgrid for Education", Power Systems, IEEE Transactions on, Year: 2014, Volume: 29, Issue: 4, pp 1952 – 1962
- [4] Maseda, F. J.; Martija, I.; Martija, I. "A Training Tool and Methodology to Allow Concurrent Multidisciplinary Experimental Projects in Engineering Education", Education, IEEE Transactions on, On page(s): 357 - 364 Volume: 55, Issue: 3, Aug. 2012
- [5] T. W. Gedra; Seungwon An; Q. H. Arsalan; S. Ray, "Unified power engineering laboratory for electromechanical energy conversion, power electronics, and power systems", IEEE Transactions on Power Systems, 2004, Volume: 19, Issue: 1, Pages: 112 – 119
- [6] Cagnano, A.; De Tuglie, E.; Dicorato, M.; Forte, G.; Trovato, M., "PrInCE Lab experimental microgrid Planning and operation issues", Environment and Electrical Engineering (EEEIC), 2015 IEEE 15th International Conference on, 2015, pp 1671 – 1676
- [7] Leger, Aaron St.; Spruce, Jeremy, "Photovoltaic energy integration laboratory and experiments", T&D Conference and Exposition, 2014 IEEE PES, Pages: 1 – 5
- [8] Sbordone, D.A.; Moyeenull Huq, K.M.; Baran, M. "An experimental microgrid for laboratory activities", Environment and Electrical Engineering (EEEIC), 2015 IEEE 15th International Conference, pp 363 – 36
- [9] Albu, M.; Boicea, A.V.; Calin, M.; Popa, M., "Emerging smart grid topics in electrical engineering education" PowerTech, 2011 IEEE Trondheim, pp 1 – 6
- [10] Santoso, S.; Lwin, M.; Ramos, J.; Singh, M.; Muljadi, E.; Jonkman, J. "Designing and Integrating Wind Power Laboratory Experiments in Power and Energy Systems Courses", Power Systems, IEEE Transactions on, On page(s): 1944 - 1951 Volume: 29, Issue: 4, July 2014
- [11] R. Pecun; A. Nayir, "Design and implementation of a 12 kW wind-solar distributed power and instrumentation system as an educational testbed for Electrical Engineering Technology students", Modern Electric Power Systems (MEPS), 2010 Proceedings of the International Symposium.
- [12] Chowdhury, B.; Parkhideh, B.; Martin, A.; Salami, Z.; Enslin, J.; Cecchi, V.; Kamalasan, S.; Maciej, N. "Enhancing power and energy systems concepts with laboratory experience", Power and Energy Society General Meeting (PES), 2013 IEEE, On page(s): 1 – 5
- [13] Collins, E. R. "An Energy Conversion Laboratory Using Industrial-Grade Equipment", Power Systems, IEEE Transactions on, On page(s): 3 - 11 Volume: 24, Issue: 1, Feb. 2009
- [14] Hodder, A.; Kawkabani, B. "An advanced teaching lab for the setting up of an islanded production unit", Electrical Machines (ICEM), 2012 XXth International Conference on, On page(s): 2046 - 2052
- [15] N. Hosseinzadeh; M. R. Hesamzadeh "Application of Project-Based Learning (PBL) to the Teaching of Electrical Power Systems Engineering", IEEE Transactions on Education, 2012, Volume: 55, Issue: 4, Pages: 495 – 501
- [16] C. M. Saviz; K. C. Schulz; W. J. King; R. H. Turpin "Assessment measures to enhance teaching and curriculum effectiveness", 31st Annual Frontiers in Education Conference. Impact on Engineering and Science Education. Conference Proceedings (Cat. No.01CH37193), Year: 2001, Volume: 1, Pages: TIA - 7-TIA-12 vol.1