

Accepted Manuscript

Isothermal Organic Rankine Cycle (ORC) driving Reverse Osmosis (RO) Desalination: experimental investigation and case study using R245fa working fluid

O.N. Igobo, P.A. Davies

PII: S1359-4311(17)36582-1

DOI: <https://doi.org/10.1016/j.applthermaleng.2018.02.056>

Reference: ATE 11838

To appear in: *Applied Thermal Engineering*

Received Date: 13 October 2017

Revised Date: 26 January 2018

Accepted Date: 15 February 2018

Please cite this article as: O.N. Igobo, P.A. Davies, Isothermal Organic Rankine Cycle (ORC) driving Reverse Osmosis (RO) Desalination: experimental investigation and case study using R245fa working fluid, *Applied Thermal Engineering* (2018), doi: <https://doi.org/10.1016/j.applthermaleng.2018.02.056>

This is a PDF file of an unedited manuscript that has been accepted for publication. As a service to our customers we are providing this early version of the manuscript. The manuscript will undergo copyediting, typesetting, and review of the resulting proof before it is published in its final form. Please note that during the production process errors may be discovered which could affect the content, and all legal disclaimers that apply to the journal pertain.



Isothermal Organic Rankine Cycle (ORC) driving Reverse Osmosis (RO) Desalination: experimental investigation and case study using R245fa working fluid

O. N. Igobo and P. A. Davies*

Sustainable Environment Research Group, School of Engineering and Applied Science,
Aston University, Birmingham, B4 7ET, UK

*Corresponding author: p.a.davies@aston.ac.uk

Abstract

In many regions of the world, groundwater salinity contributes to the growing fresh water deficit. Desalination of saline water via reverse osmosis (RO) could be driven by Organic Rankine cycle (ORC) engines, exploiting readily available low-grade heat (e.g solar or waste heat). However, the specific energy consumption (SEC) of conventional ORC-RO systems is quite high, while the ORC efficiency is significantly low at low temperatures. To improve on the efficiency and SEC of brackish ground water desalination processes, a novel isothermal ORC driven batch RO desalination system was experimentally investigated, using R245fa working fluid. Results showed about a half of the energy requirement of conventional ORC-RO desalination systems. A case study indicated that the system can be potentially employed in recovering waste heat from a bakery facility to produce about 0.4 L of fresh water per kg of baked food.

Keywords: Waste heat recovery; Reverse Osmosis (RO) desalination; organic Rankine cycle (ORC); quasi-isothermal.

1. Introduction

In many regions of the world, groundwater salinity contributes to the growing fresh water deficit. Fresh water can be recovered from saline water via Reverse Osmosis (RO) desalination. This is a mechanical separation technique which involves the application of pressure to saline water against a semi-permeable membrane, such that water is forced through the membrane as permeate, leaving behind the salt as concentrate. The pressure energy required for the RO desalination process could be driven by an Organic Rankine cycle (ORC) heat engine, exploiting readily available low-grade heat (e.g solar or waste heat).

Though the practical application of heat engines to RO desalination is yet to attain full commercialisation, research studies are albeit advancing in the literature [1, 2]. Manolakos et al. [3] experimented with a R134a ORC-RO desalination system, operated from a 75°C heat source. The reported thermal cycle efficiency was 1.17%, and 2.55 m³ (per 9 hours) of fresh water was produced from seawater, at a SEC of 2.3 kWh/m³ (8.28 kJ/L). In an experimental study by Libert and Maurel [4], brackish water desalination system driven by R11 ORC (operated on 92°C solar heat) achieved thermal ORC efficiency of 2.2%, fresh water output of 130 L/m²/day, and SEC of 1 kWh/m³. Generally, the practical performance of

conventional RO systems are in the range of 0.7 – 1 kWh/m³ and 2 – 3 kWh/m³ specific mechanical energy consumption for brackish water and sea water respectively [5], with ORC efficiencies often less than 5% at low grade heat sources (<90°C) [6, 7]. To this effect, an isothermal ORC [8, 9] has been introduced, wherein heat is continuously added to the working fluid during expansion, to improve specific work output and thus improve the cycle efficiency. In addition, a batch RO desalination system, DesaLink [10, 11] has also been introduced to balance the driving pressure with feed brackish water osmotic pressure, thus reducing the desalination energy consumption.

This paper aims to establish the feasibility of integrating the isothermal ORC to drive the DesaLink batch desalination system, via experiment; and present a case study. Many of the ORC-RO desalination studies in the literature [1, 12] are conceived to be driven by solar heat, although ORC can also be ideally operated on waste heat sources, as has been widely investigated for other applications (especially electricity generation); whereas the application of operating ORC-RO desalination on waste heat source is scarce in the literature. As such, the case study will be presented to demonstrate a potential application when driven by waste heat recovered from an industrial process, e.g., oven exhaust of an industrial bakery facility, for combined production of food and water.

2. ORC-RO DesaLink Experiment

2.1. Experimental setup

The integrated isothermal ORC-RO DesaLink system is shown in Figure 1, while Figure 2 is a schematic representation of the system. The DesaLink machine has a saline water feed line, a water cylinder, RO membrane, circulating pump, a triangular crank linkage mechanism, and a power cylinder (with integrated ORC unit) – which provides the driving force.

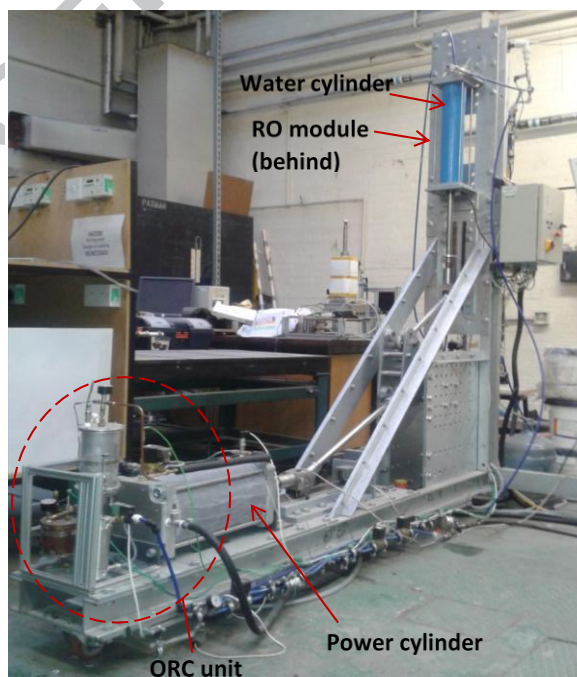
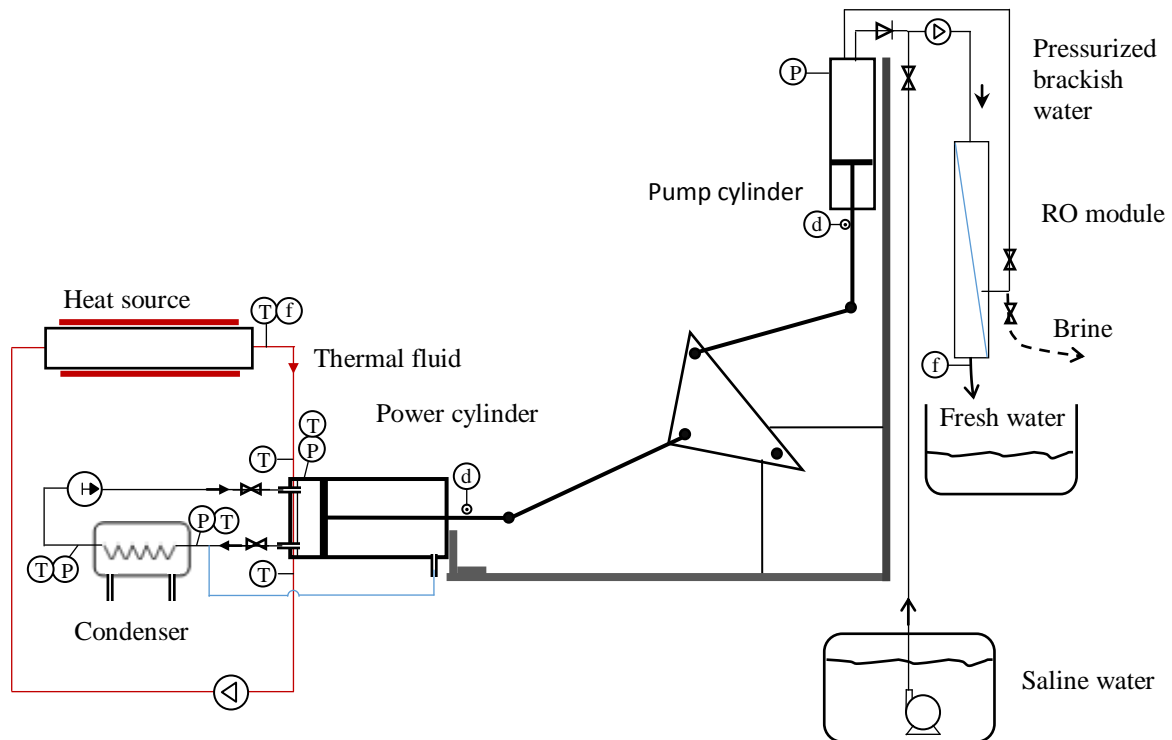

Figure 1. The DesaLink machine fitted with the isothermal ORC system



Key

- ▶ Closed ▶ Open
 ⊕ Temperature sensor ⊕ Pressure sensor ⊕ Flow meter ⊕ Displacement transducer
 ⊕ Metering pump ⊕ Circulating pump ⊕ Feed pump

Figure 2. Schematics of the isothermal ORC DesaLink system

On operation, liquid working fluid injected into the heated power cylinder evaporates, expands and exerts pressure on the piston, thus driving the triangular crank linkage mechanism, at increasing mechanical advantage, thus pressurizing a batch of brackish water in the water pump cylinder through the RO module where fresh water is filtered out as permeate. To overcome the low side pressure of the ORC closed cycle, the other (piston rod) side of the power cylinder is connected to the condenser, to provide a back pressure, so as to facilitate the return stroke. The overall performance of the integrated system is characterised by the mechanical SEC; however the performance of the ORC loop is characterised by the achieved pressure level in the power cylinder, the work output, and the thermal cycle efficiency of the ORC loop (the governing equations have already been presented in [8]). On the other hand, the performance of the RO loop is characterised by the average desalting rate i.e. the volume of water produced in relation to the time of operation per cycle. A detailed model and analysis of the system is available in [10]. In general, the desalting rate is proportional to the pressure exerted in the water cylinder, while the water pressure is in turn proportional to the pressure in the power cylinder and the mechanical advantage due to the linkage geometry between the two cylinders. As the power piston advances, the working fluid expands and thus the pressure decreases; however, the

mechanical advantage increases (from <1 to >7) due to the trigonometric arrangement of the linkage mechanism; consequently the force/pressure available in the water piston is increased [11].

In the construction of the system, for the RO subunit, the water pump cylinder was a 105 mm bore diameter pressure vessel, the recirculating pump was a Wilo, 3 m³/h max flow volume pump, while the RO membrane was Dow FILMTEC™ BW30-2540. The saline water feed line included a 200 L water barrel, 0.7 hp submersible pump and cartridge filters. The ORC subunit included the power cylinder (200 mm bore diameter), a condenser and a metering pump for the R245fa working fluid. The condenser was fabricated as a counter-flow double helix coil-in-tube heat exchanger. The inlet and exit of the condenser were fitted with thermocouples and pressure gauges. A liquid receiver was attached at the coil (working fluid) exit of the condenser, to collect the condensate from the condenser before being fed to the metering pump, this serves as a buffer tank to minimise pressure fluctuations in the condenser and to avoid bubbles of vapour getting into the pump. While the metering pump was adapted from a 50 mm bore, double acting cylinder pump, fitted with non-return valves. On the other hand, the original cylinder base of the power cylinder was replaced with a bespoke fabricated cylinder base with integrated finned heat exchanger design (to serve as evaporator). The thermal fluid employed (to be circulated through the finned cylinder base) was ethylene glycol and water mixture, with a mixing ratio of 70 vol% (glycol) to elevate the boiling point temperature to about 120°C. The thermal fluid circulation system included a 5 litre stainless steel kettle with 2 kW immersion heater, fitted with a thermocouple and temperature control unit; Grundfos 15-60 domestic circulating pump moves the thermal fluid through the system via a steam hose. The inlet and exit of the cylinder base were also equipped with thermocouples.

All thermocouples utilized in the measurements were K-type. 1.5 mm diameter stainless steel mineral insulated thermocouples were used for measuring the fluid temperatures at different positions in the rig, while welded tip thermocouples were used for surface measurements. Conversely, the pressure transducers utilized were Gems™ sensors with 0.25% accuracy. Displacement transducers were implemented with Variohm® linear slide membrane potentiometers to measure the stroke lengths of the power and water pump pistons, to enable calculations of the swept volumes (see Table 2 for further details). The control architecture and data acquisition of the rig was based on DAQs and LabVIEW® software from National Instruments (NI).

Table 2: Details of instruments used in the experiments.

Instruments	Model/type	Range	Accuracy
Thermocouples	K-type	-40 – 1100 °C	±2.2 °C
Pressure transducers	Gems™ 3100	0 – 16 bar	±0.25%
Displacement transducer	Variohm® IPL	500 mm	±3%
Flow meter	Gems™ FT-210	0.1 – 2.5 L/min	±3%

Conductivity meter	Hannah HI-8633	Multirange	±1%
--------------------	----------------	------------	-----

2.2. Test procedure

Upon setting up the test rig, the saline water loop was first flushed with tap water, which was previously dechlorinated using 2 ppm sodium-metabisulfite solution to protect the RO membrane from oxidation by chlorine attack. The feed saline water was prepared from sodium chloride (NaCl) solution, to the appropriate concentration (4000 ppm). The saline feed water was also flushed through the system to get a uniform salinity through the pipe work, and to bleed off pockets of trapped air. The heating system was activated and the temperature was set to 95°C and sufficient time was allowed for the system temperature to stabilise and achieve steady state, whilst the thermal fluid was circulated through the cylinder base. The metering pump stroke was set to correspond to the desired liquid volume, afterwards the start operation was activated, and a metered volume of the working fluid liquid was injected into the cylinder base.

2.3. Results

With the heat source temperature and power respectively set at 95°C and 1.5 kW, and a thermal fluid flow rate of 50 L/min, the set-point temperature and steady state was achieved in about half hour. The thermal fluid arrived the power cylinder base evaporator with less than 3°C drop in temperature; however, the fluid exit temperature very closely matched the inlet, with temperature drop of about 0.13°C. On the other hand, the temperature at the evaporator internal surface (exposed to the R245fa working fluid) was about 8°C less.

The performance of the ORC cycle can be accessed with the aid of the R245fa pressure profile in the power cylinder, with respect to time corresponding to the cylinder stroke volume, as shown in Figure 3a. Upon injection, the R245fa liquid evaporated at an average pressure (gauge) of 7.5 bar, which reduced to 2 bar at the end of the expansion, and was blown down to the condenser pressure of 0.7 bar at the release of the exhaust valve. Here, the work output computed directly from the p-V profile represents the indicated work; however, the actual work is eventually obtained by subtracting the losses due to friction at the cylinder seals. Based on the manufacturer's details for the low-friction cylinder (without cushion) employed, the minimum pressure required to overcome the friction at the piston seal could be as low as 0.05 bar for the large bore (200 mm) cylinder employed, however during operation, the pressure equivalent of the seal's sliding resistance varies linearly with the operating pressure at a gradient of less than 1% of the operating pressure [13].

The evaporation phase together with the expansion phase of the R245fa constitutes the pressurisation phase of the saline water, during which, fresh water is continuously permeated out from the RO module. At the end of the pressurisation phase, a waiting time of 60 seconds was set to allow further permeate to drip out the module, because the water pressure at the end of the expansion stage (14 - 18 bar) was significantly higher than the osmotic pressure of the bulk solution (about 4 bar); as a result, the pressure difference was sufficient to drive additional fresh

water through the membrane. During this waiting time, the water pressure decreased sharply, as freshwater is removed from the system with no further external pressure applied. The cumulative volume of the permeated fresh water is shown in Figure 3b; the volume increased uniformly at a rate that depends on the water pressure, and a total of about 2.3 L of fresh water was obtained. The freshwater concentration is shown in Figure 4, alongside the flow rate through the duration of operation. The permeate concentration decreases with increasing flow rate (despite an anticipated increase in feed concentration and thus, salt passage across the membrane during the operating stroke), since more water is permeated to dilute the transported salts. Consequently, a mean concentration of about 500 ppm was achieved for the batch of permeate. At the end of the water production of the waiting time, the purging process commenced, with new saline water (about 1 L) pumped through the RO module to wash out the accumulated brine from the membrane. After the purging, the power cylinder's exhaust valve was released (and the power pressure drops down to the condenser pressure) to set it for the return stroke; then the next batch of feed saline water refilled the water cylinder, with both pistons returning to their initial positions.

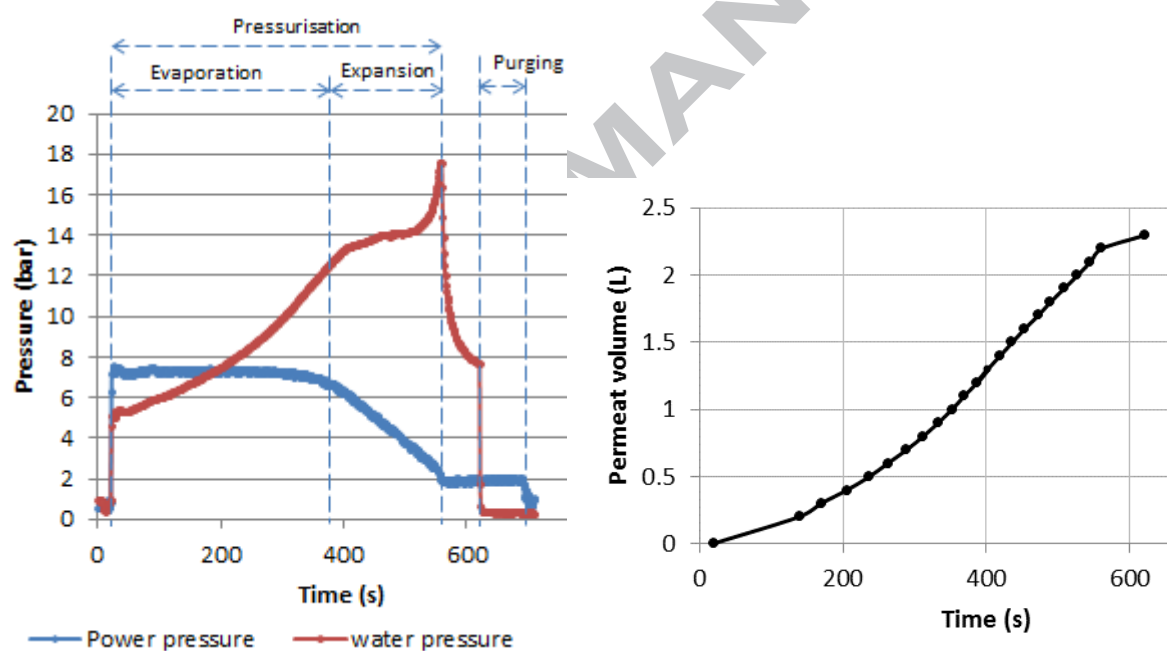

Figure 3 (a) pressure (gauge) profiles in the power and water cylinders (b) profile of the cumulative permeate volume

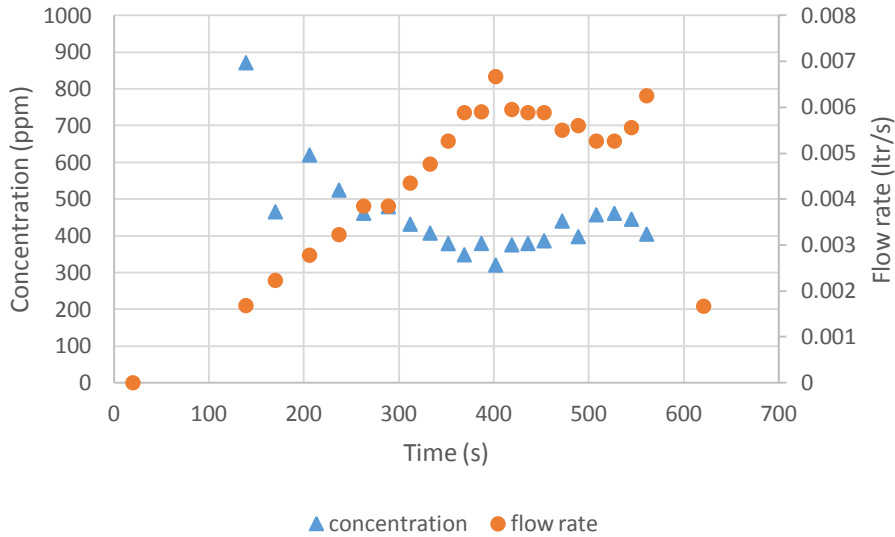

Figure 4 Variation of the concentration and flow rate of the permeate with time,

Based on the results, for each cycle of operation, net work of about 2.85 kJ was performed by the power cylinder per cycle, with ORC efficiency of about 7.7%, to produce 2.3 L of fresh water from the RO module. This equates to a mechanical specific energy consumption of 0.34 kWh/m³ (1.24 kJ/L), which is about a half of the of the energy requirement of conventional ORC-RO brackish water desalination systems.

For the achieved specific energy consumption, an estimate of the error involved due to measurement uncertainty (in the experimental process) can be considered. The relative error can be obtained in the form of

$$\frac{\Delta z}{z} = \frac{1}{z} \sum \frac{\partial z}{\partial x} \Delta x_i$$

Where, z represent the specific energy consumption, while x represent the dependent variables (power pressure, piston displacement volume, permeate volume). The overall relative error in the specific energy consumption is found to be $\pm 6.7\%$; with the piston displaced volume having the most influence while the pressure has the least.

3. Case study

3.1. Case study description

Having established the performance of the integrated isothermal ORC-RO DesaLink system, here a case study is presented to predict the potential performance of the system when powered by waste heat recovery. For the purpose of this study, the case site is tentatively located in the United States of America (USA), owing to its abundance of waste heat resource [14] and considerable ground water salinity. In the USA, brackish groundwater resource is vastly available in the southern states like Texas, New Mexico, Oklahoma, and California [15]; however, New Mexico is one of the states where the phenomenon is most acute. Although, the salinity of the groundwater varies across the state, salinity of about 4000 ppm has been reported in Alamogordo town, in Otero County, in the southern-central area of the State [16].

Information available at the town's chamber of commerce portal [17] indicated that though there are reasonable business activities, especially goods and services, there are only a handful of manufacturing and process industries. One notable such industry is a bakery – Western Baking Corporation. Western Baking Corporation [18] is a large commercial bakery facility, located on a 28-acre land parcel in Alamogordo, New Mexico; and specialized in the production of a wide range of cookies and crackers. The bakery facility has several high-end bakery equipment including five Baker Perkins' 100 m, 7-zone direct gas fired ovens. The facility, on operation, bakes about 1360 to 1814 kg of product per hour, with a total heat consumption rate of about 769 – 1795 kW (depending on the product baked); thus signifying a bakery specific gas energy consumption of 1.53 – 4.75 MJ per kg of baked dough. The ovens are generally operated for about 20 to 24 hours daily. Direct gas fired ovens are widely used in baking industries. The baking chamber is heated directly with gas burners, with baking temperatures often exceeding 200°C; flue gas from the combustion (together with water vapour, traces of fat and particulates from the baking) gets ducted from the different zones and exhausted through chimney/stack, with typical flue gas temperature exceeding 120°C [19]. In the production of cookies and crackers, the baking process represents about 78% of the total energy requirement [20], while studies have also shown that, for a typical direct fired gas oven baking, about 20% of the gas energy is wasted in the exhaust [21, 22]; thus signifying a substantial potential for exhaust waste heat recovery.

To harness energy from the flue gas, appropriate waste heat recovery systems such as gas-to-liquid heat pipe heat exchanger could be installed in the oven exhaust stacks to capture the flue gas energy (as depicted in Figure 5). Here, changeover dampers could be employed to divert the flue gas through the heat exchanger, where the flue heat is transferred to the thermal fluid (ethylene glycol) which is circulated through the evaporator (finned cylinder base) of the ORC DesaLink system, to provide the needed heat in driving the system.

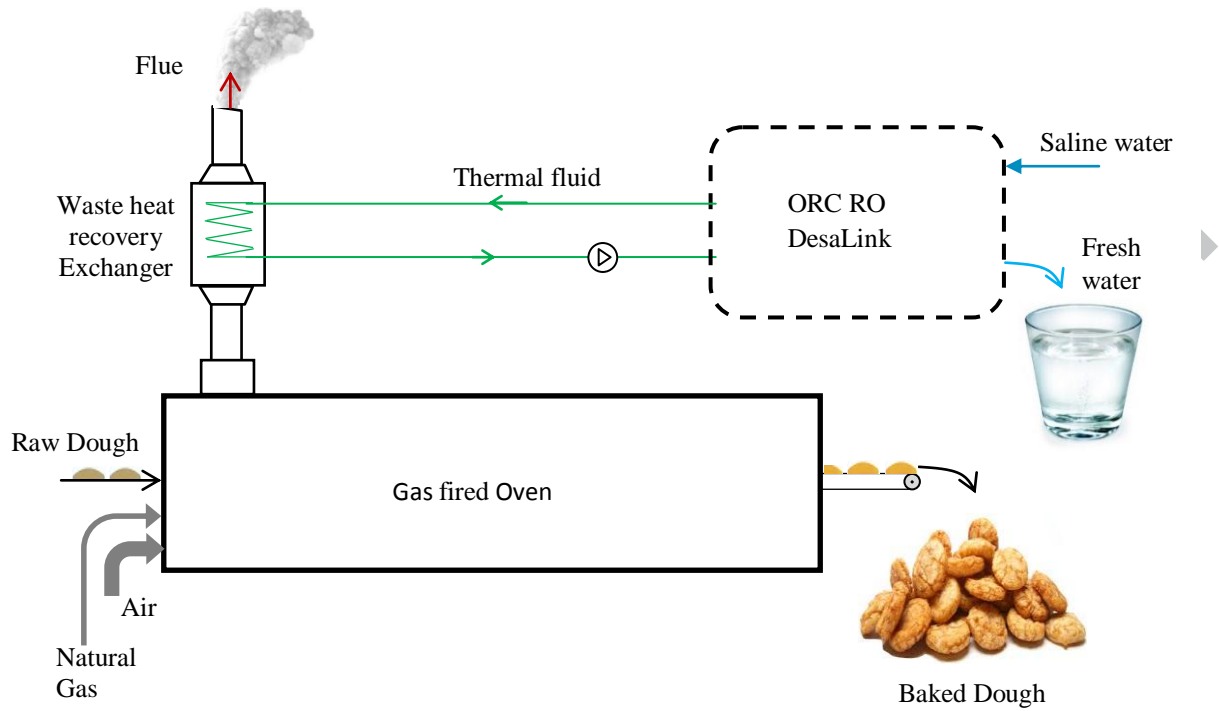

Figure 5: Schematic of the bakery waste heat recovery ORC DesaLink desalination set-up

In waste-heat recovery heat exchanger (WHRX) applications, the heat pipe heat exchangers are preferred when the flue gas contains substances and particles that could lead to fouling and clogging which could consequently hamper heat exchanger effectiveness. The construction of the heat exchanger allows the heat pipe surfaces to be easily accessible and cleaned quickly with very little system down-time; design options with self-cleaning mechanisms are also available; other advantages include durability, compactness and low pressure drops [23, 24].

3.2. Theory

Although a sizeable portion of the gas energy is contained in the flue gas, in reality not all of this quantity is available for recovery at a given operating condition. Ideally, the quantity of the recoverable energy would determine the potential desalination capacity.

The water desalination rate can be estimated in terms of the heat recovery rate and the desalination specific energy consumptions as

$$\dot{V}_w = \frac{\dot{Q}_g \eta_{htf} \eta_{ORC}}{SEC_{mech}} \quad (1)$$

where η_{htf} is the heat transfer efficiency from the thermal fluid to the power cylinder base evaporator, thus taking into consideration heat loss from the power cylinder to the ambient (this was found to be about 45%), η_{ORC} is the ORC thermal efficiency and SEC_{mech} is the RO desalination specific energy consumption.

The heat transferred, \dot{Q}_g , from the flue gas to the thermal fluid can be given by energy balance

$$\dot{Q}_g = \rho_g \dot{V}_g c_{p_g} (T_{g,i} - T_{g,o}) = \rho_{htf} \dot{V}_{htf} c_{p_{htf}} (T_{htf,o} - T_{htf,i}) \quad (2)$$

Where, ρ_g , \dot{V}_g , c_{p_g} and ρ_{htf} , \dot{V}_{htf} , $c_{p_{htf}}$ are the density, volumetric flow rate, heat capacity of the flue gas and the thermal fluid respectively; $T_{g,i}$, $T_{g,o}$ and $T_{htf,i}$, $T_{htf,o}$ are the inlet and outlet temperatures of the flue gas and the thermal fluid respectively entering and leaving the heat exchanger.

The temperatures of the thermal fluid at the cylinder evaporator are adopted as per the experiment (see section 2). Now, taking the power cylinder return line as the inlet to the WHRX, the thermal fluid inlet temperature at the WHRX can be obtained accordingly. On the other hand, the flue gas inlet temperature at the WHRX is taken as that from the oven's exhaust, while the outlet temperature is assumed to be 10°C above incoming thermal fluid temperature.

The volumetric flow rate of the flue gas is taken as the sum of the natural gas fuel flow rate at the burners (of the oven) and the flow rate of the air required for complete combustion and that of the gases released from the dough during baking. The amount (volume) of air relative to that of the gas fuel used in the combustion can be estimated from the air-fuel ratio, AFR, (The AFR, by volume, for complete combustion of natural gas is taken as 9.4:1), assuming ideal combustion efficiency of 100%.

Hence, the flue gas volumetric flow rate can be given as:

$$\dot{V}_g = \frac{\dot{Q}_{fuel}}{HV} + \frac{\dot{Q}_{fuel}}{HV} AFR + \mathbb{G} \cdot PR \quad (3)$$

Alternatively, the flow rate can also be given in terms of the gas energy consumption of baking as

$$\dot{V}_g = PR \left[\frac{E_{bake}}{HV} + \frac{E_{bake}}{HV} AFR + \mathbb{G} \right] \quad (4)$$

Where, \dot{Q}_{fuel} is the heat level of the ovens' gas burner (kJ/hr); HV is the lower heating value of the natural gas fuel, taken as 36 MJ/m³; PR is the baking production rate i.e. the total mass of doughs baked per hour (kg/hr); and \mathbb{G} is the volume of gases released (from the dough) per unit mass of dough baked, studies have shown this to be about 0.115 m³/kg for bread baking [22] and the same is assumed for the cookies and cracker; E_{bake} is the average gas energy consumption per unit mass of dough baked.

The thermo-physical properties (density and specific heat) of the flue gas are estimated based on the composition of the combined gasses from the combustion product and the baked product. Generally, natural gas fuel combustion product consists mainly of nitrogen (75%), carbon dioxide (13%), water vapour (11%) and others (1%); while the baked product gas (emitted from the dough during baking) consists mainly of water vapour (89%), carbon dioxide (5.4%) and others (5.6%) [22]. The combined composition of the flue gas (for the present parameters stated above) can be deduced to be: nitrogen – 65.6%, carbon dioxide – 12%, water vapour – 20.8%

and others – 1.6%. With the above combined composition, the thermo-physical properties are estimated, using a web based flue gas calculator tool, FGKH® [25]. The specific heat and the density are obtained as 1.13 kJ/kg°C and 0.91 kg/m³ respectively.

3.3. Results

With the flue gas properties (temperature, density and specific heat), including the WHRX and ORC temperatures, ORC efficiency and RO specific energy consumption defined in the previous sections, the actual quantity of heat transferred from the flue gas to the ORC-RO DesaLink system via the thermal fluid is determined; and then the quantity of desalted water that can be produced, based on the quantity of the recovered heat, is determined. As depicted in Figure 6, the result shows that, for a typical average baking production rate of 1500 kg/h (with average natural gas energy consumption of 2.9 MJ/kg_{dough} and flue gas temperature of 120°C), about 2.5% of the exhaust heat (21 MJ) is recovered and utilised by multiple units of the ORC DesaLink system to desalinate about 664 L of water per hour, thus yielding a daily fresh water production of about 13.3 m³/day. It is interesting that such large quantity of fresh water can be produced from a very small fraction of the exhaust heat.

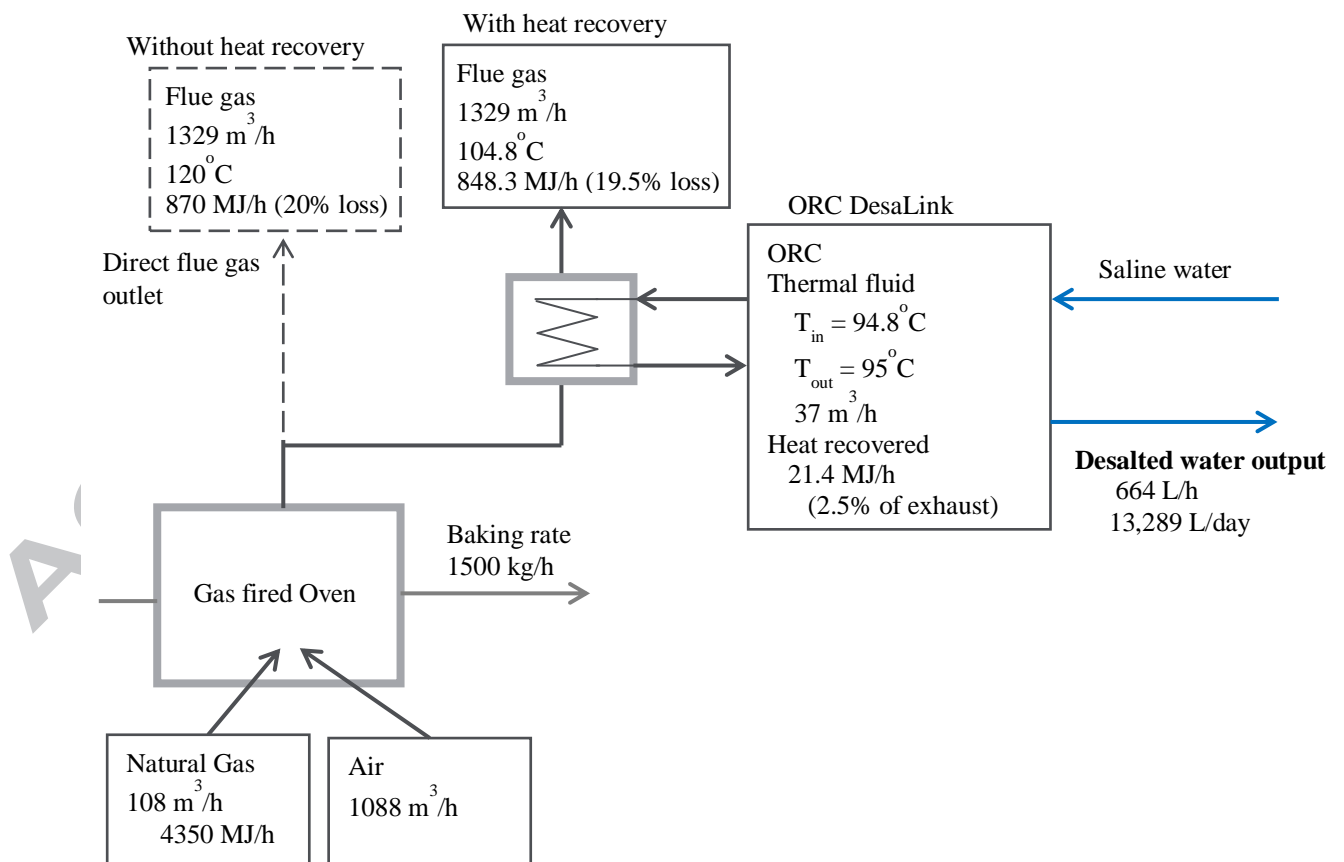

Figure 6: Schematic of the system set up, operating parameters and results

Figure 7 shows the potential desalination hourly and daily fresh water production rates varying linearly with the bakery production rate; indicating that, up to 16,000 L/day could be desalted with a bakery rate of 1750 kg/h for the bakery average gas energy consumption of 2.9 MJ/kg_{dough}. However, depending on the type of product baked, given that, the gas energy consumed per unit mass of dough baked at the bakery facility varies from 1.53 to 4.75 MJ/kg_{dough}; correspondingly, the water desalted is deduced to vary from 386 to 1040 L/h, i.e., 7,732 – 20,792 L/day.

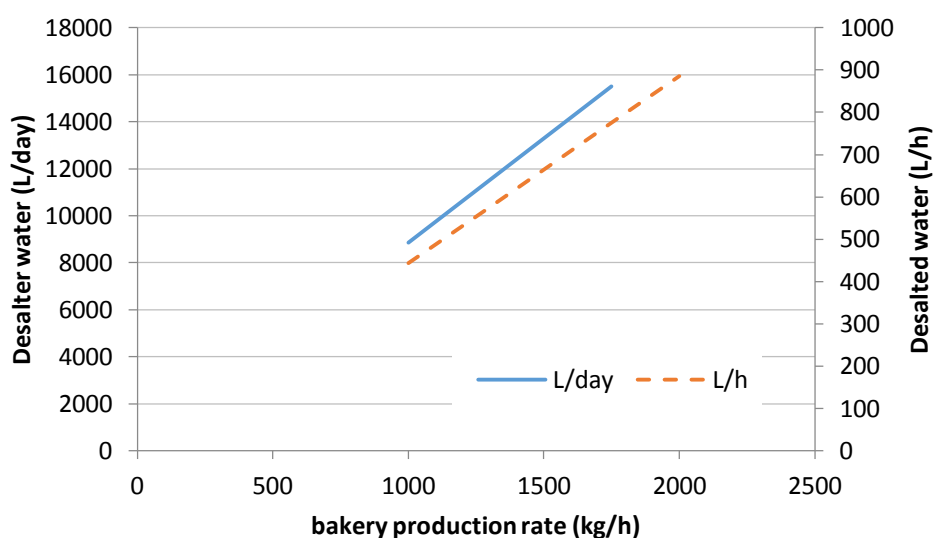

Figure 7: Potential fresh water production rate variation with bakery production rate

4. Conclusions

To improve on the efficiency and specific energy consumption of brackish groundwater desalination processes, a novel isothermal ORC batch desalination system was developed. Experimental results showed a specific energy consumption of 0.34 kWh/m³ – equivalent to about half of the energy requirement of conventional ORC-RO desalination systems. A case study carried out to demonstrate the potential performance of the system in a practical scenario, indicated that the novel system can be potentially employed in recovering waste heat from an industrial bakery facility to produce about 0.4 L of fresh water per kg of baked food.

From a broader perspective, this work has shown how a systematic approach towards favouring thermodynamically ideal processes can greatly boost the energy efficiency of thermally-driven desalination. The result of 0.34 kWh/m³, besides improving on earlier ORC-RO studies, is much superior to thermal processes using distillation – which generally require specific energy

consumption $>15 \text{ kWh/m}^3$. The new system has substantial potential for energy and water saving both in individual factories, and for industrial complexes where reject heat may be available at different temperatures from a variety of processes. For future work, it is very important to make the system more compact through improved mechanical design (see [26]). It will also be important to speed up heat transfer for a shorter cycle time and faster output, which could be achieved in a number of ways, for example through nanoparticle enhancement to heat transfer [27]. This is also expected to improve the salt rejection in the system, albeit with marginal sacrifice in energy efficiency.

Acknowledgement

We acknowledge support from the School of Engineering and Applied Science, Aston University, in the form of a PhD scholarship to O. N. Igobo.

References

- [1] C. Li, Y. Goswami, E. Stefanakos, Solar assisted sea water desalination: A review, *Renewable and Sustainable Energy Reviews*, 19 (2013) 136-163.
- [2] A.M. Delgado-Torres, L. García-Rodríguez, Design recommendations for solar organic Rankine cycle (ORC)-powered reverse osmosis (RO) desalination, *Renewable and Sustainable Energy Reviews*, 16 (2012) 44-53.
- [3] D. Manolakos, G. Kosmadakis, S. Kyritsis, G. Papadakis, On site experimental evaluation of a low-temperature solar organic Rankine cycle system for RO desalination, *Solar Energy*, 83 (2009) 646-656.
- [4] J. Libert, A. Maurel, Desalination and renewable energies-a few recent developments, *Desalination*, 39 (1981) 363-372.
- [5] S. Burn, M. Hoang, D. Zarzo, F. Olewniak, E. Campos, B. Bolto, O. Barron, Desalination techniques — A review of the opportunities for desalination in agriculture, *Desalination*, 364 (2015) 2-16.
- [6] S. Declaye, S. Quoilin, L. Guillaume, V. Lemort, Experimental study on an open-drive scroll expander integrated into an ORC (Organic Rankine Cycle) system with R245fa as working fluid, *Energy*, 55 (2013) 173-183.
- [7] S.H. Kang, Design and experimental study of ORC (organic Rankine cycle) and radial turbine using R245fa working fluid, *Energy*, 41 (2012) 514-524.
- [8] O.N. Igobo, P.A. Davies, Low-temperature organic Rankine cycle engine with isothermal expansion for use in desalination, *Desalination and Water Treatment*, 55 (2015) 3694-3703.
- [9] O.N. Igobo, P.A. Davies, Review of low-temperature vapour power cycle engines with quasi-isothermal expansion, *Energy*, 70 (2014) 22-34.
- [10] T. Qiu, O. Igobo, P. Davies, DesaLink: solar powered desalination of brackish groundwater giving high output and high recovery, *Desalination and water treatment*, 51 (2013) 1279-1289.
- [11] P.A. Davies, A solar-powered reverse osmosis system for high recovery of freshwater from saline groundwater, *Desalination*, 271 (2011) 72-79.
- [12] S.M. Shalaby, Reverse osmosis desalination powered by photovoltaic and solar Rankine cycle power systems: A review, *Renewable and Sustainable Energy Reviews*, 73 (2017) 789-797.
- [13] SMC: Smooth Cylinder/Low Speed Cylinder, in, <http://content2.smcetech.com/pdf/smoothcylinder.pdf>, accessed 24/12/2015.
- [14] BCS Inc. Waste heat recovery: technologies and opportunities in U.S. industry, in, US Dept. of Energy (DOE) 2008.
- [15] National Brackish Groundwater Assessment, in, <http://www.usgs.gov/water/>, U.S Geological Survey (USGS), USA, accessed 6/8/2015.
- [16] Desalination of saline and brackish water is becoming more affordable, *Membrane Technology*, 2009 (2009) 8-10.

- [17] Alamogordo chamber of commerce., in, <http://www.alamogordo.com/>, Alamogordo, New Mexico, USA, accessed 1/5/2015.
- [18] Western Baking Corporation, in, <http://www.westernbaking.com/>, accessed 2/5/2015.
- [19] Industrial Energy Efficiency Accelerator - Guide to the industrial bakery sector, in, The Carbon Trust, London, UK.
- [20] P. Therkelsen, E. Masanet, E. Worrell, Energy efficiency opportunities in the US commercial baking industry, *Journal of Food Engineering*, 130 (2014) 14-22.
- [21] C.A. Stear, Control Technology and Energy Recovery, in: *Handbook of Breadmaking Technology*, Springer, 1990, pp. 620-637.
- [22] Carbon Trust. Improving the efficiency of bakery ovens - Case study, in, The Carbon Trust, London, UK, April, 2015.
- [23] J. Danielewicz, M.A. Sayegh, B. Śniechowska, M. Szulgowska-Zgrzywa, H. Jouhara, Experimental and analytical performance investigation of air to air two phase closed thermosyphon based heat exchangers, *Energy*, 77 (2014) 82-87.
- [24] Energy recovery from exhaust gases using Heat Pipe technology, in, http://www.spiraxsarco.com/Documents/Energy_recovery_from_exhaust_gases_using_Heat_Pipe_technology-Sales%20Brochure.pdf, accessed 6/8/2015.
- [25] FGKH. Flue Gas Know How, in, <http://fluegasknowhow.com/flue-gas-properties/> accessed 5/7/2015.
- [26] A. Mudgal, P.A. Davies, A cost-effective steam-driven RO plant for brackish groundwater, *Desalination*, 385 (2016) 167-177.
- [27] G. Song, P.A. Davies, J. Wen, G. Xu, Y. Quan, Nucleate pool boiling heat transfer of SES36 fluid on nanoporous surfaces obtained by electrophoretic deposition of Al₂O₃, *Applied Thermal Engineering*, (2017), in press

Highlights

- An Organic Rankine Cycle (ORC) – Reverse Osmosis (RO) machine has been constructed
- It was tested using R245fa working fluid
- A Specific Energy Consumption (SEC) of about 0.34 kWh/m³ was achieved.
- A case study highlighted the potential for waste heat energy recovery from an industrial bakery facility
- It is predicted that the system could desalinate 0.4 litres fresh water per kg of baked food.

ACCEPTED MANUSCRIPT