

# 43Gbit/s RZ-DQPSK Transmission Over 1000km of G.652 Ultra-Low-Loss Fibre with 250km Amplifier Spans

M.E. McCarthy<sup>(1)</sup>, L.M. Gleeson<sup>(1)</sup>, M.F.C. Stephens<sup>(1)</sup>, I.D. Phillips<sup>(1)</sup>, W. Forsyiaik<sup>(1)</sup>  
C.R. Towery<sup>(2)</sup>, S. Ten<sup>(2)</sup>

<sup>(1)</sup> Ericsson Ltd, Ansty Park, Ansty, CV7 9RD.

<sup>(2)</sup> Corning Incorporated, 1 Riverfront Plaza, Corning, NY 14831, USA.

**Abstract** We demonstrate 40x43Gbit/s RZ-DQPSK transmission over 1000km of ultra-low-loss G.652 fibre with 250km amplifier spacing. Hybrid Raman-EDFA amplification with co- and contra-directional Raman pumping enables 27dB Raman gain per span and error-free post-FEC performance.

## Introduction

The inexorable trend towards longer transmission distances, higher client side data rates and increased capacity has seen Raman amplification become a commercially viable technology with a wide range of applications over recent years<sup>1</sup>. With data rates of 43Gbit/s now economically attractive<sup>2</sup>, the OSNR improvement afforded by hybrid Raman-EDFA amplification is a key enabling technology in supporting either longer transmission distances with typical amplifier spacings of 80-100km<sup>3</sup>, or an increased amplifier spacing for shorter reach systems, thereby reducing the number of intermediate sites and their associated capex and opex costs<sup>4</sup>. Given this driver towards lowering the number of amplifier sites, another enabling technology to have received attention in recent years is ultra-low-loss (ULL) fibre, offering the potential for cabled fibre losses as low as 0.17dB/km and the doubling of typical amplifier spacings when used in conjunction with hybrid Raman-EDFA amplification.

Following these trends we recently reported 40x43Gbit/s over a 5x200km system based on Corning® SMF-28® ULL G.652 fibre and a hybrid Raman-EDFA architecture using contra directional Raman pumping<sup>5</sup>. In this paper, we extend that work by introducing co-directional Raman pumping to enhance the previously reported configuration, allowing 40x43Gbit/s over 4x250km to be demonstrated with error free post-FEC performance and Raman gains of 27dB per span.

## Experimental Setup

The transmission link, Fig. 1, uses Corning SMF-28 ULL fibre with co- and contra-directional Raman amplification and a mix of single stage and mid stage access EDFAs according to the dispersion map requirements<sup>6,7</sup>. The transmit

and receive terminals are equipped with 40x43Gbit/s wavelength tuneable RZ-DQPSK transponder units arranged across the C-band on a 100GHz grid.

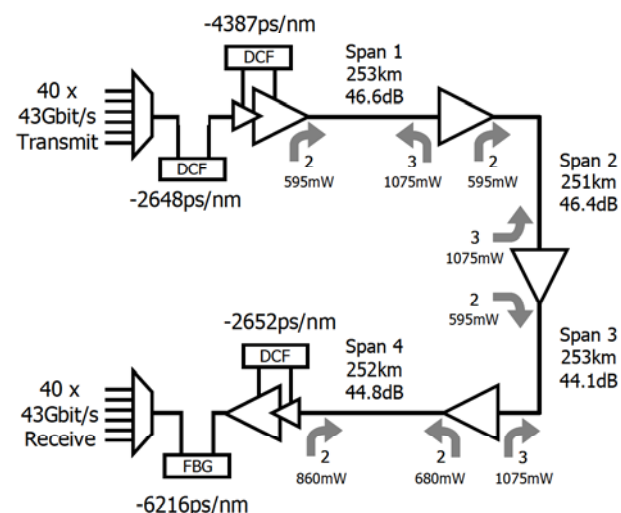

**Fig. 1:** Experimental set-up. The arrows indicate the directionality of the Raman pumping and the numerical subscripts indicate the number of pump wavelengths and the total pump power.

Each of the transponder units is independently modulated by a  $2^{31}-1$  PRBS pattern mapped into an STM-256 SDH frame and a G.709 digital wrapper with a 7% FEC overhead. There is no polarisation management of the system resulting in a complete decorrelation of the polarisation states of adjacent channels and a random exploration of polarisation space over time. Dispersion and dispersion slope compensation in the transmit terminal is performed using standard G.652 dispersion compensating fibre (DCF). Due to its attenuation, the DCF is allocated between the input and mid stage of the transmit EDFA as illustrated. The pre-compensation of -7035ps/nm at 1550nm is 45% of the system requirement.

The transmission link of 4×250km spans is constructed with Corning SMF-28 ULL fibre on shipping spools with an intrinsic fibre attenuation <0.17dB/km at 1550nm. After patching and splicing of these spools to form transmission spans, losses ranging from 44.1dB to 46.6dB are achieved. The average fibre dispersion is 16.0ps/nm/km at 1550nm, whilst the link fibre PMD co-efficient is  $\leq 0.04\text{ps}/\sqrt{\text{km}}$ . In-line dispersion compensation is not performed at the three intermediate amplifier sites where single stage EDFAs are configured. Using an embedded VOA, both the terminal and line EDFAs are a variable gain design ranging from 17dB to 27dB gain, with a maximum output power of +20.5dBm.

The co-directional Raman is a dual pump design with depolarised wavelengths of 1425nm and 1452nm. Three out of the four contra-directional Raman pumps are a triple pump design with depolarised pump wavelengths of 1424nm, 1435nm and 1459nm. All pump wavelengths are capable of a maximum output power of 430mW. Due to equipment availability, the fourth contra-directional pump was the same dual pump design as the co-directional units.

At the receiving terminal, the 40 channels are de-multiplexed with each transponder unit independently performing active tuneable dispersion compensation, and optimization of its delay line interferometers and decision threshold settings to optimize the pre-FEC BER. Dispersion and dispersion slope compensation in the receive terminal is performed using a combination of standard G.652 DCF with a dispersion of -2652ps/nm at 1550nm, and Fibre Bragg Gratings (FBG) that are compatible with a 100GHz channel spacing, totalling -6216ps/nm at 1550nm. The receiver post compensation corresponds to 55% of the system requirement and is distributed as illustrated in Fig. 1.

## Results and Discussion

The system optimisation is a balance between the co- and contra-directional Raman amplifiers and the EDFAs, and the same settings for these 3 subsystems are applied to each of the spans, with the exception of Span 4 where the lack of a triple pump unit meant that the dual pump units were run at the higher powers indicated in Fig.1. The optimisation of Raman gain spectra is typically a trade off between maximising the total pump power and consequently the gain, whilst simultaneously adjusting the ratios of the individual pump powers to achieve the desired gain profile. To illustrate this, Fig. 2 shows example Raman gain spectra from the co- and contra-directional pumps on Span 1.

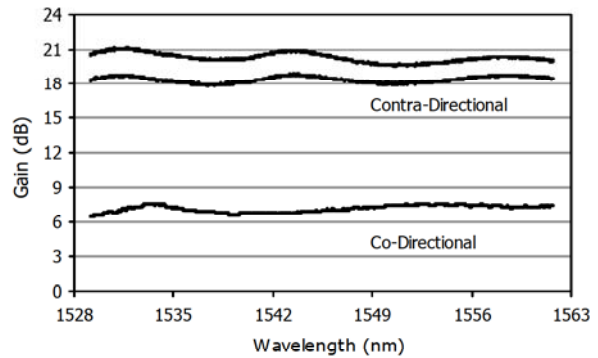

**Fig. 2:** Example Raman Gain spectra of dual pump co-directional and triple pump contra-directional pumping. Average gains of 7.1dB, 18.3dB and 20.3dB obtained for total pump powers of 595mW, 947mW and 1075mW respectively.

Considering first the contra-directional pumping, two gain spectra (upper traces) are illustrated showing the three gain peaks characteristic of a triple wavelength Raman pump unit. The lower of these two traces corresponds to a pump unit optimised for a flat average gain of 18.3dB and a gain ripple of 0.9dB with pump powers of 323mW, 194mW and 430mW for the pump wavelengths of 1424nm, 1435nm and 1459nm respectively. However, considering the system pre-FEC performance, the optimum contra-directional configuration is found to have a tilted gain spectrum to compensate partially for the fibre attenuation tilt across the C-band and the intra C-band Raman power transfer. This results in the upper gain profile in Fig. 2, with an average gain of 20.3dB and a gain tilt of -0.9dB across the C-band for pump powers of 387mW, 258mW and 430mW respectively. In both of these instances the total pump power and resultant gain is limited by the longest wavelength pump running at its maximum rating whilst simultaneously maintaining the ratio of pump powers to give the required gain tilt and ripple.

The optimisation of the dual wavelength co-directional pump unit follows a similar approach in terms of adjusting pump ratios to achieve the desired gain. However, to avoid significant non-linear transmission penalties, the optimum setting in terms of BER performance is found by reducing the EDFA output powers whilst simultaneously increasing the co-directional Raman pump powers. In this instance, the optimum EDFA launch power is +15dBm into each of the fibre spans, corresponding to -1dBm per channel, with a flat launch power profile. Similarly, the Raman pump unit is optimised for a flat average gain of 7.1dB and a gain ripple of 0.8dB with pump powers of 245mW and 350mW for the pump wavelengths of 1425nm and 1452nm, respectively. This gain spectrum is the



lower trace in Fig. 2, and in contrast to the contra-pumping, is as flat as possible in order to minimise any non-linear penalties, and therefore limited by optimum system performance rather than pump output power. Additionally, each in-line EDFA is configured to operate with a gain tilt of -2dB to further compensate for the fibre attenuation tilt across the C-band and the intra C-band Raman power transfer. In conjunction with the contra-directional Raman, the resulting total gain tilt per span is -2.9dB.

The receiver terminal 40×43Gbit/s spectrum resulting from the transmission and described optimisations is shown in Fig. 3(a). The accumulated ripple of the 12 amplification stages is 6.7dB and is determined largely by the ~0.8dB ripple per Raman amplifier in the region of 1533nm to 1539nm for both the dual and triple pump units, Fig. 2. Fig. 3(b) presents the optimised pre-FEC BER measurements for the 40×43Gbit/s RZ-DQPSK transponders, each averaged over a 15 minute gating period along with the corresponding OSNR measurements. The worst pre-FEC BER is  $<10^{-3}$ , indicating a small margin with respect to the enhanced FEC threshold of  $2 \times 10^{-3}$  for a post FEC BER  $< 10^{-15}$  and no post FEC errors were observed during the course of these measurements. The OSNR is the ratio between the integrated signal power and the noise power in a 0.1nm bandwidth and is strongly correlated with the BER. The system susceptibility to non-linear penalties discussed earlier was primarily manifested in the region of 1533nm where the power peaking due to the accumulated ripple is most pronounced. Conversely the worst performance corresponds to the low OSNR and signal power in the region of 1539nm and the system optimisation was effectively a trade-off between these non-linear and OSNR limited signals. It is anticipated that management of the accumulated gain ripple by means of gain equalisation would result in a more uniform BER and OSNR across the C-band.

Comparison of the average back-to-back RZ-DQPSK transponder performance against the data in Fig. 3(b) suggests a moderate OSNR penalty of approximately 1.5dB for transmission over the reported configuration, indicating that the performance is dominated by the received OSNR. Moreover, the DCF-free, inter terminal optical path is well suited to the requirements of the first generation of 100Gbit/s interfaces<sup>8-10</sup>, where optimum performance is achieved with electronic dispersion compensation<sup>8</sup>, offering a potential upgrade path to higher data rates using the configuration reported here.

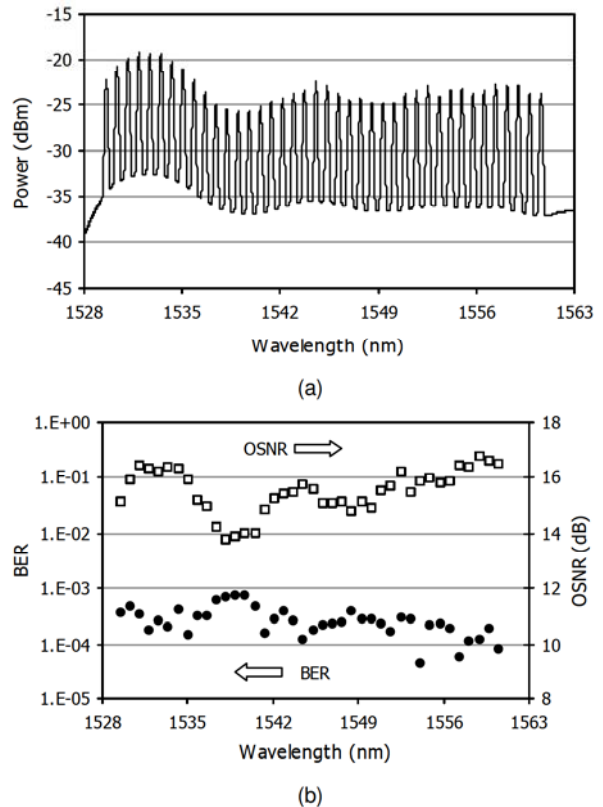

**Fig. 3:** (a) Output Spectrum from monitor port of receive terminal amplifier and (b) recorded BERs and OSNR at receive terminal.

## Conclusions

We have demonstrated 40×43Gbit/s RZ-DQPSK transmission over 1000km of Corning® SMF-28® ULL fibre with 250km amplifier spacing. Using co- and contra-directional Raman pumping to achieve 27dB of Raman gain per span, four consecutive inter-amplifier losses in excess of 44dB are traversed, enabling 40×43Gbit/s over 1000km with only three intermediate amplifier sites. Such a reduction in infrastructure is of particular interest to network operators given the associated cost savings.

## References

- 1 J. Bromage et al. J. Lightwave Technol. 22 (1), 225, 2004.
- 2 C. Fuerst et al. OFC/NFOEC 2008, NTuB2.
- 3 E. Pincemin et al., OFC/NFOEC 2009, OThC2.
- 4 D.Z. Chen et al., OFC 2005, OTuH6.
- 5 L.M. Gleeson et al., OFC/NFOEC 2010, NTuC1.
- 6 J.H.B. Nijhof et al., CLEO 2006, CThE3.
- 7 D. van den Borne et al., ECOC 2006, Mo3.2.
- 8 K. Roberts et al., J. Lightwave Technol. 27 (16), 3546, 2009.
- 9 H. Wernz et al., ECOC 2009, 3.4.3.
- 10 M. Birk et al., OFC/NFOEC 2010, PDPD1.