

# Weakly-supervised Joint Sentiment-Topic Detection from Text

Chenghua Lin, Yulan He, Richard Everson, *Member, IEEE*, and Stefan R uger, *Fellow, HEA*

**Abstract**—Sentiment analysis or opinion mining aims to use automated tools to detect subjective information such as opinions, attitudes, and feelings expressed in text. This paper proposes a novel probabilistic modeling framework called joint sentiment-topic (JST) model based on latent Dirichlet allocation (LDA), which detects sentiment and topic simultaneously from text. A reparameterized version of the JST model called Reverse-JST, by reversing the sequence of sentiment and topic generation in the modelling process, is also studied. Although JST is equivalent to Reverse-JST without hierarchical prior, extensive experiments show that when sentiment priors are added, JST performs consistently better than Reverse-JST. Besides, unlike supervised approaches to sentiment classification which often fail to produce satisfactory performance when shifting to other domains, the weakly-supervised nature of JST makes it highly portable to other domains. This is verified by the experimental results on datasets from five different domains where the JST model even outperforms existing semi-supervised approaches in some of the datasets despite using no labelled documents. Moreover, the topics and topic sentiment detected by JST are indeed coherent and informative. We hypothesize that the JST model can readily meet the demand of large-scale sentiment analysis from the web in an open-ended fashion.

**Index Terms**—Sentiment analysis, opinion mining, latent Dirichlet allocation (LDA), joint sentiment-topic (JST) model.



## 1 INTRODUCTION

WITH the explosion of Web 2.0, various types of social media such as blogs, discussion forums and peer-to-peer networks present a wealth of information that can be very helpful in assessing the general public's sentiment and opinions towards products and services. Recent surveys have revealed that opinion-rich resources like online reviews are having greater economic impact on both consumers and companies compared to the traditional media [1]. Driven by the demand of gleaning insights into such great amounts user-generated data, work on new methodologies for automated sentiment analysis and discovering the hidden knowledge from unstructured text data has bloomed splendidly.

Among various sentiment analysis tasks, one of them is sentiment classification, i.e., identifying whether the semantic orientation of the given text is positive, negative or neutral. Although much work has been done in this line [2]–[7], most of the existing approaches rely on supervised learning models trained from labelled corpora where each document has been labelled as positive or negative prior to training. However, such labelled corpora are not always easily obtained in practical applications. Also, it is well-known that sentiment classifiers trained on one domain often fail to produce satisfactory results when shifted to another domain, since sentiment expressions can be quite different in different domains

[7], [8]. For example, it is reported in [8] that the in-domain Support Vector Machines (SVMs) classifier trained on the movie review data (giving best accuracy of 90.45%) only achieved relatively poor accuracies of 70.29% and 61.36%, respectively, when directly tested in the book review and product support services data. Moreover, aside from the diversity of genres and large-scale size of the web corpora, user-generated content such as online reviews evolves rapidly over time, which demands much more efficient and flexible algorithms for sentiment analysis than the current approaches can offer. These observations have thus motivated the problem of using unsupervised or weakly-supervised approaches for domain-independent sentiment classification.

Another common deficiency of the aforementioned work is that it only focuses on detecting the overall sentiment of a document, without performing an in-depth analysis to discover the latent topics and the associated topic sentiment. In general, a review can be represented by a mixture of topics. For instance, a standard restaurant review will probably discuss topics or aspects such as food, service, location, price, and etc. Although detecting topics is a useful step for retrieving more detailed information, the lack of sentiment analysis on the extracted topics often limits the effectiveness of the mining results, as users are not only interested in the overall sentiment of a review and its topical information, but also the sentiment or opinions towards the topics discovered. For example, a customer is happy about food and price, but may at the same time be unsatisfied with the service and location. Moreover, it is intuitive that sentiment polarities are dependent on topics or domains. A typical example is that when appearing under different topics of the movie review domain, the

- C. Lin and R. Everson are with Computer Science, College of Engineering, Mathematics and Physical Sciences, University of Exeter, EX4 4QF, UK. E-mail: {cl322, R.M.Everson}@exeter.ac.uk
- Y. He and S. R uger are with Knowledge Media Institute, The Open University, Milton Keynes, MK7 6AA, UK. E-mail: {Y.He,S.Rueger}@open.ac.uk

adjective “*complicated*” may have negative orientation as “*complicated role*” in one topic, and conveys positive sentiment as “*complicated plot*” in another topic. Therefore, detecting topic and sentiment simultaneously should serve a critical function in helping users by providing more informative sentiment-topic mining results.

In this paper, we focus on document-level sentiment classification for general domains in conjunction with topic detection and topic sentiment analysis, based on the proposed weakly-supervised joint sentiment-topic (JST) model [9]. This model extends the state-of-the-art topic model latent Dirichlet allocation (LDA) [10], by constructing an additional sentiment layer, assuming that topics are generated dependent on sentiment distributions and words are generated conditioned on the sentiment-topic pairs. Our model distinguishes from other sentiment-topic models [11], [12] in that: (1) JST is weakly-supervised, where the only supervision comes from a domain independent sentiment lexicon; (2) JST can detect sentiment and topics simultaneously. We suggest that the weakly-supervised nature of the JST model makes it highly portable to other domains for the sentiment classification task. While JST is a reasonable design choice for joint sentiment-topic detection, one may argue that the reverse is also true that sentiments may vary according to topics. Thus, we also studied a reparameterized version of JST, called the Reverse-JST model, in which sentiments are generated dependent on topic distributions in the modelling process. It is worth noting that without hierarchical prior, JST and Reverse-JST are essentially two reparameterizations of the same model.

Extensive experiments have been conducted with both the JST and Reverse-JST models on the movie review (MR)<sup>1</sup> and multi-domain sentiment (MDS) datasets<sup>2</sup>. Although JST is equivalent to Reverse-JST without hierarchical priors, experimental results show that when sentiment prior information is encoded, these two models exhibit very different behaviors, with JST consistently outperforming Reverse-JST in sentiment classification. The portability of JST in sentiment classification is also verified by the experimental results on the datasets from five different domains, where the JST model even outperforms existing semi-supervised approaches in some of the datasets despite using no labelled documents. Aside from automatically detecting sentiment from text, JST can also extract meaningful topics with sentiment associations as illustrated by some topic examples extracted from the two experimental datasets.

The rest of the paper is organized as follows. Section 2 introduces the related work. Section 3 presents the JST and Reverse-JST models. We show the experimental setup in Section 4 and discuss the results on the movie review and multi-domain sentiment datasets in Section

5. Finally, Section 6 concludes the paper and outlines the future work.

## 2 RELATED WORK

### 2.1 Sentiment Classification

Machine learning techniques have been widely deployed for sentiment classification at various levels, e.g., from the document-level, to the sentence and word/phrase-level. On the document-level, one tries to classify documents as positive, negative or neutral, based on the overall sentiments expressed by opinion holders. There are several lines of representative work at the early stage [2], [3]. Turney and Littman [2] used weakly-supervised learning with mutual information to predict the overall document sentiment by averaging out the sentiment orientation of phrases within a document. Pang *et al.* [3] classified the polarity of movie reviews with the traditional supervised machine learning approaches and achieved the best results using SVMs. In their subsequent work [4], the sentiment classification accuracy was further improved by employing a subjectivity detector and performing classification only on the subjective portions of reviews. The annotated movie review dataset (also known as polarity dataset) used in [3], [4] has later become a benchmark for many studies [5], [6]. Whitelaw *et al.* [5] used SVMs to train on the combination of different types of appraisal group features and bag-of-words features, whereas Kennedy and Inkpen [6] leveraged two main sources, i.e., General Inquirer and *Choose the Right Word* [13], and trained two different classifiers for the sentiment classification task.

As opposed to the work [2]–[6] that only focused on sentiment classification in one particular domain, some researchers have addressed the problem of sentiment classification across domains [7], [8]. Aue and Gamon [8] explored various strategies for customizing sentiment classifiers to new domains, where training is based on a small number of labelled examples and large amounts of unlabelled in-domain data. It was found that directly applying classifier trained on a particular domain barely outperforms the baseline for another domain. In the same vein, more recent work [7], [14] focused on domain adaptation for sentiment classifiers. Blitzer *et al.* [7] addressed the domain transfer problem for sentiment classification using the structural correspondence learning (SCL) algorithm, where the frequent words in both source and target domains were first selected as candidate pivot features and pivots were then chosen based on mutual information between these candidate features and the source labels. They achieved an overall improvement of 46% over a baseline model without adaptation. Li and Zong [14] combined multiple single classifiers trained on individual domains using SVMs. However, their approach relies on labelled data from all domains to train an integrated classifier and thus may lack flexibility to adapt the trained classifier to other domains where no label information is available.

1. <http://www.cs.cornell.edu/people/pabo/movie-review-data>

2. <http://www.cs.jhu.edu/~mdredze/datasets/sentiment/index2.html>

All the aforementioned work shares some similar limitations: (1) they only focused on sentiment classification alone without considering the mixture of topics in the text, which limits the effectiveness of the mining results to users; (2) most of the approaches [3], [4], [7], [15] favor supervised learning, requiring labelled corpora for training and potentially limiting the applicability to other domains of interest.

Compared to the traditional topic-based text classification, sentiment classification is deemed to be more challenging as sentiment is often embodied in subtle linguistic mechanisms such as the use of sarcasm or incorporated with highly domain-specific information. Among various efforts for improving sentiment detection accuracy, one of the directions is to incorporate prior information from the general sentiment lexicon (i.e., words bearing positive or negative sentiment) into sentiment models. These general lists of sentiment lexicons can be acquired from domain-independent sources in many different ways, i.e., from manually built appraisal groups [5], to semi-automatically [16] or fully automatically [17] constructed lexicons. When incorporating lexical knowledge as prior information into a sentiment-topic model, Andreevskaia and Bergler [18] integrated the lexicon-based and corpus-based approaches for sentence-level sentiment annotation across different domains. A recently proposed non-negative matrix tri-factorization approach [19] also employed lexical prior knowledge for semi-supervised sentiment classification, where the domain-independent prior knowledge was incorporated in conjunction with domain-dependent unlabelled data and a few labelled documents. However, this approach performed worse than the JST model on the movie review data even with 40% labelled documents as will be discussed in Section 5.

## 2.2 Sentiment-Topic Models

JST models sentiment and mixture of topics simultaneously. Although work in this line is still relatively sparse, some studies have preserved a similar vision [11], [12], [20]. Most closely related to our work is the Topic-Sentiment Model (TSM) [11], which models mixture of topics and sentiment predictions for the entire document. However, there are several intrinsic differences between JST and TSM. First, TSM is essentially based on the probabilistic latent semantic indexing (pLSI) [21] model with an extra background component and two additional sentiment subtopics, whereas JST is extended based on LDA. Second, regarding topic extraction, TSM samples a word from the background component model if the word is a common English word. Otherwise, a word is sampled from either a topical model or one of the sentiment models (i.e., positive or negative sentiment model). Thus, in TSM the word generation for positive or negative sentiment is not conditioned on topic. This is a crucial difference compared to the JST model as in JST one draws a word from the distribution

over words jointly conditioned on both topic and sentiment label. Third, for sentiment detection, TSM requires postprocessing to calculate the sentiment coverage of a document, while in JST the document sentiment can be directly obtained from the probability distribution of sentiment label given a document.

Other models by Titov and McDonald [12], [20] are also closely related to ours, since they are all based on LDA. The Multi-Grain Latent Dirichlet Allocation model (MG-LDA) [20] is argued to be more appropriate to build topics that are representative of ratable aspects of customer reviews, by allowing terms being generated from either a global topic or a local topic. Being aware of the limitation that MG-LDA is still purely topic based without considering the associations between topics and sentiments, Titov and McDonald further proposed the Multi-Aspect Sentiment model (MAS) [12] by extending the MG-LDA framework. The major improvement of MAS is that it can aggregate sentiment text for the sentiment summary of each rating aspect extracted from MG-LDA. Our model differs from MAS in several aspects. First, MAS works on a supervised setting as it requires that every aspect is rated at least in some documents, which is infeasible in real-world applications. In contrast, JST is weakly-supervised with only minimum prior information being incorporated, which in turn is more flexible. Second, the MAS model was designed for sentiment text extraction or aggregation, whereas JST is more suitable for the sentiment classification task.

## 3 METHODOLOGY

### 3.1 Joint Sentiment-Topic (JST) Model

The LDA model, as shown in Figure 1(a), is based upon the assumption that documents are mixture of topics, where a topic is a probability distribution over words [10], [22]. Generally, the procedure of generating a word in a document under LDA can be broken down into two stages. One first chooses a distribution over a mixture of  $T$  topics for the document. Following that, one picks up a topic randomly from the topic distribution, and draws a word from that topic according to the corresponding topic-word distribution.

The existing framework of LDA has three hierarchical layers, where topics are associated with documents, and words are associated with topics. In order to model document sentiments, we propose a joint sentiment-topic (JST) model [9] by adding an additional sentiment layer between the document and the topic layer. Hence, JST is effectively a four-layer model, where sentiment labels are associated with documents, under which topics are associated with sentiment labels and words are associated with both sentiment labels and topics. A graphical model of JST is represented in Figure 1(b).

Assume that we have a corpus with a collection of  $D$  documents denoted by  $C = \{d_1, d_2, \dots, d_D\}$ ; each document in the corpus is a sequence of  $N_d$  words denoted by  $d = (w_1, w_2, \dots, w_{N_d})$ , and each word in the

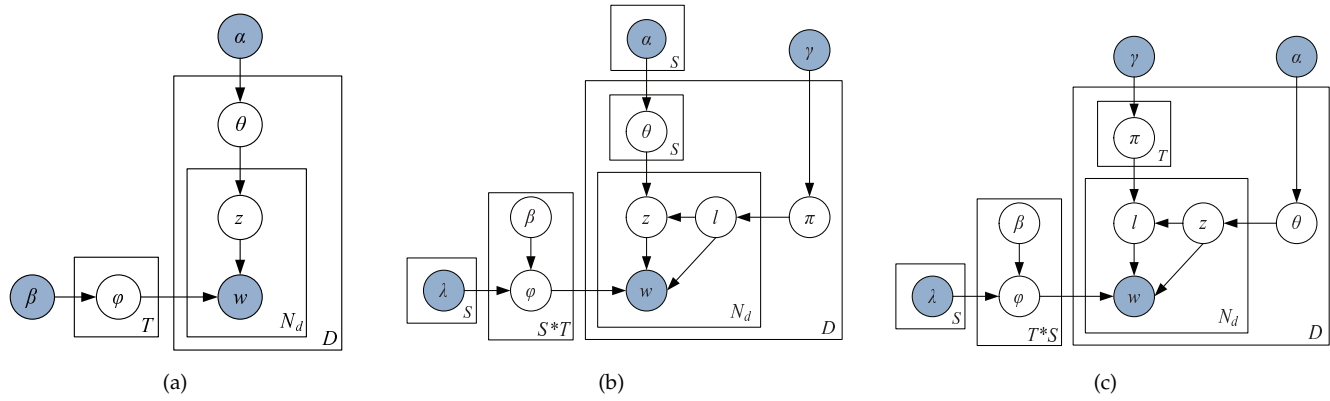

Fig. 1. (a) LDA model; (b) JST model; (c) Reverse-JST model.

document is an item from a vocabulary index with  $V$  distinct terms denoted by  $\{1, 2, \dots, V\}$ . Also, let  $S$  be the number of distinct sentiment labels, and  $T$  be the total number of topics. The procedure of generating a word  $w_i$  in document  $d$  under JST boils down to three stages. First, one chooses a sentiment label  $l$  from the per-document sentiment distribution  $\pi_d$ . Following that, one chooses a topic from the topic distribution  $\theta_{d,l}$ , where  $\theta_{d,l}$  is conditioned on the sampled sentiment label  $l$ . It is worth noting that the topic distribution of JST is different from that of LDA. In LDA, there is only one topic distribution  $\theta$  for each individual document. In contrast, in JST each document is associated with  $S$  (number of sentiment labels) topic distributions, each of which corresponds to a sentiment label  $l$  with the same number of topics. This feature essentially provides means for the JST model to predict the sentiment associated with the extracted topics. Finally, one draws a word from the per-corpus word distribution conditioned on both topic and sentiment label. This is again different from LDA that in LDA a word is sampled from the word distribution only conditioned on topic.

The formal definition of the generative process in JST corresponding to the graphical model shown in Figure 1(b) is as follows:

- For each sentiment label  $l \in \{1, \dots, S\}$ 
  - For each topic  $j \in \{1, \dots, T\}$ , draw  $\varphi_{lj} \sim \text{Dir}(\lambda_l \times \beta_{lj}^T)$ .
- For each document  $d$ , choose a distribution  $\pi_d \sim \text{Dir}(\gamma)$ .
- For each sentiment label  $l$  under document  $d$ , choose a distribution  $\theta_{d,l} \sim \text{Dir}(\alpha)$ .
- For each word  $w_i$  in document  $d$ 
  - choose a sentiment label  $l_i \sim \text{Mult}(\pi_d)$ ,
  - choose a topic  $z_i \sim \text{Mult}(\theta_{d,l_i})$ ,
  - choose a word  $w_i$  from  $\varphi_{l_i z_i}$ , a Multinomial distribution over words conditioned on topic  $z_i$  and sentiment label  $l_i$ .

The hyperparameters  $\alpha$  and  $\beta$  in JST can be treated as the prior observation counts for the number of times topic  $j$  associated with sentiment label  $l$  sampled from a

document and the number of times words sampled from topic  $j$  associated with sentiment label  $l$ , respectively, before having observed any actual words. Similarly, the hyperparameter  $\gamma$  can be interpreted as the prior observation counts for the number of times sentiment label  $l$  sampled from a document before any word from the corpus is observed. In our implementation, we used asymmetric prior  $\alpha$  and symmetric prior  $\beta$  and  $\gamma$ . In addition, there are three sets of latent variables that we need to infer in JST, i.e., the per-document sentiment distribution  $\pi$ , the per-document sentiment label specific topic distribution  $\theta$ , and the per-corpus joint sentiment-topic word distribution  $\varphi$ . We will see later in the paper that the per-document sentiment distribution  $\pi$  plays an important role in determining the document sentiment polarity.

### Incorporating Model Prior

We modified Phan’s GibbsLDA++ package<sup>3</sup> for the implementation of JST and Reverse-JST. Compared to the original LDA model, besides adding a sentiment label generation layer, we also added an additional dependency link of  $\varphi$  on the matrix  $\lambda$  of size  $S \times V$ , which we used to encode word prior sentiment information into the JST and Reverse-JST models. The matrix  $\lambda$  can be considered as a transformation matrix which modifies the Dirichlet priors  $\beta$  of size  $S \times T \times V$ , so that the word prior sentiment polarity can be captured.

The complete procedure of incorporating prior knowledge into the JST model is as follows. First,  $\lambda$  is initialized with all the elements taking a value of 1. Then for each term  $w \in \{1, \dots, V\}$  in the corpus vocabulary and for each sentiment label  $l \in \{1, \dots, S\}$ , if  $w$  is found in the sentiment lexicon, the element  $\lambda_{lw}$  is updated as follows

$$\lambda_{lw} = \begin{cases} 1 & \text{if } S(w) = l \\ 0 & \text{otherwise} \end{cases}, \quad (1)$$

where the function  $S(w)$  returns the prior sentiment label of  $w$  in a sentiment lexicon, i.e., neutral, positive or negative. For example, the word “excellent” with index

3. <http://gibbslda.sourceforge.net/>

$i$  in the vocabulary has a positive sentiment polarity. The corresponding row vector in  $\lambda$  is  $[0, 1, 0]$  with its elements representing neutral, positive, and negative prior polarity. For each topic  $j \in \{1, \dots, T\}$ , multiplying  $\lambda_{li}$  with  $\beta_{lji}$ , only the value of  $\beta_{posji}$  is retained, and  $\beta_{neuji}$  and  $\beta_{negji}$  are set to 0. Thus, “*excellent*” can only be drawn from the positive topic word distributions generated from a Dirichlet distribution with parameter  $\beta_{pos}$ .

The previously proposed DiscLDA [23] and Labeled LDA [24] also utilize a transformation matrix to modify Dirichlet priors by assuming the availability of document class labels. DiscLDA uses a class-dependent linear transformation to project a  $K$ -dimensional ( $K$  latent topics) document-topic distribution into a  $L$ -dimensional space ( $L$  document labels), while Labeled LDA simply defines a one-to-one correspondence between LDA’s latent topics and document labels. In contrast to this work, we use word prior sentiment as supervised information and modify the topic-word Dirichlet priors for sentiment classification.

### Model Inference

In order to obtain the distributions of  $\pi$ ,  $\theta$ , and  $\varphi$ , we firstly estimate the posterior distribution over  $z$  and  $l$ , i.e., the assignment of word tokens to topics and sentiment labels. The sampling distribution for a word given the remaining topics and sentiment labels is  $P(z_t = j, l_t = k | \mathbf{w}, \mathbf{z}^{-t}, \mathbf{l}^{-t}, \boldsymbol{\alpha}, \beta, \gamma)$ , where  $\mathbf{z}^{-t}$  and  $\mathbf{l}^{-t}$  are vector of assignments of topics and sentiment labels for all the words in the collection except for the word at position  $t$  in document  $d$ .

The joint probability of the words, topics and sentiment label assignments can be factored into the following three terms:

$$P(\mathbf{w}, \mathbf{z}, \mathbf{l}) = P(\mathbf{w} | \mathbf{z}, \mathbf{l}) P(\mathbf{z}, \mathbf{l}) = P(\mathbf{w} | \mathbf{z}, \mathbf{l}) P(\mathbf{z} | \mathbf{l}) P(\mathbf{l}) \quad (2)$$

For the first term, by integrating out  $\varphi$ , we obtain

$$P(\mathbf{w} | \mathbf{z}, \mathbf{l}) = \left( \frac{\Gamma(V\beta)}{\Gamma(\beta)^V} \right)^{S * T} \prod_k \prod_j \frac{\prod_i \Gamma(N_{k,j,i} + \beta)}{\Gamma(N_{k,j} + V\beta)}, \quad (3)$$

where  $N_{k,j,i}$  is the number of times word  $i$  appeared in topic  $j$  and with sentiment label  $k$ ,  $N_{k,j}$  is the number of times words assigned to topic  $j$  and sentiment label  $k$ , and  $\Gamma$  is the gamma function.

For the second term, by integrating out  $\theta$ , we obtain

$$P(\mathbf{z} | \mathbf{l}) = \left( \frac{\Gamma(\sum_{j=1}^T \alpha_{k,j})}{\prod_{j=1}^T \Gamma(\alpha_{k,j})} \right)^{D * S} \prod_d \prod_k \frac{\prod_j \Gamma(N_{d,k,j} + \alpha_{k,j})}{\Gamma(N_{d,k} + \sum_j \alpha_{k,j})}, \quad (4)$$

where  $D$  is the total number of documents in the collection,  $N_{d,k,j}$  is the number of times a word from document  $d$  being associated with topic  $j$  and sentiment label  $k$ , and  $N_{d,k}$  is the number of times sentiment label  $k$  being assigned to some word tokens in document  $d$ .

For the third term, by integrating out  $\pi$ , we obtain

$$P(\mathbf{l}) = \left( \frac{\Gamma(S\gamma)}{\Gamma(\gamma)^S} \right)^D \prod_d \frac{\prod_k \Gamma(N_{d,k} + \gamma)}{\Gamma(N_d + S\gamma)}, \quad (5)$$

where  $N_d$  is the total number of words in document  $d$ .

Gibbs sampling was used to estimate the posterior distribution by sampling the variables of interest,  $z_t$  and  $l_t$  here, from the distribution over the variables given the current values of all other variables and data. Letting the superscript  $-t$  denote a quantity that excludes data from  $t^{\text{th}}$  position, the conditional posterior for  $z_t$  and  $l_t$  by marginalizing out the random variables  $\varphi$ ,  $\theta$ , and  $\pi$  is

$$P(z_t = j, l_t = k | \mathbf{w}, \mathbf{z}^{-t}, \mathbf{l}^{-t}, \boldsymbol{\alpha}, \beta, \gamma) \propto \frac{N_{k,j,w_t}^{-t} + \beta}{N_{k,j}^{-t} + V\beta} \cdot \frac{N_{d,k,j}^{-t} + \alpha_{k,j}}{N_{d,k}^{-t} + \sum_j \alpha_{k,j}} \cdot \frac{N_{d,k}^{-t} + \gamma}{N_d^{-t} + S\gamma}. \quad (6)$$

Samples obtained from the Markov chain are then used to approximate the per-corpus sentiment-topic word distribution

$$\varphi_{k,j,i} = \frac{N_{k,j,i} + \beta}{N_{k,j} + V\beta}. \quad (7)$$

The approximate per-document sentiment label specific topic distribution is

$$\theta_{d,k,j} = \frac{N_{d,k,j} + \alpha_{k,j}}{N_{d,k} + \sum_j \alpha_{k,j}}. \quad (8)$$

Finally, the approximate per-document sentiment distribution is

$$\pi_{d,k} = \frac{N_{d,k} + \gamma}{N_d + S\gamma}. \quad (9)$$

The pseudo code for the Gibbs sampling procedure of JST is shown in Algorithm 1.

### 3.2 Reverse Joint Sentiment-Topic (Reverse-JST) Model

In this section, we studied a reparameterized version of the JST model called Reverse-JST. As opposed to JST in which topic generation is conditioned on sentiment labels, sentiment label generation in Reverse-JST is dependent on topics. As shown in Figure 1(c), the Reverse-JST model is a four-layer hierarchical Bayesian model, where topics are associated with documents, under which sentiment labels are associated with topics and words are associated with both topics and sentiment labels. Using similar notations and terminologies as in Section 3.1, the joint probability of the words, the topics and sentiment label assignments of Reverse-JST can be factored into the following three terms:

$$P(\mathbf{w}, \mathbf{l}, \mathbf{z}) = P(\mathbf{w} | \mathbf{l}, \mathbf{z}) P(\mathbf{l}, \mathbf{z}) = P(\mathbf{w} | \mathbf{l}, \mathbf{z}) P(\mathbf{l} | \mathbf{z}) P(\mathbf{z}). \quad (10)$$

It is easy to derive the Gibbs sampling for Reverse-JST in the same way as JST. Therefore, here we only give the

---

**Algorithm 1** Gibbs sampling procedure of JST.

---

**Require:**  $\alpha, \beta, \gamma, \text{Corpus}$

**Ensure:** sentiment and topic label assignment for all word tokens in the corpus

- 1: Initialize  $S \times T \times V$  matrix  $\Phi$ ,  $D \times S \times T$  matrix  $\Theta$ ,  $D \times S$  matrix  $\Pi$ .
  - 2: **for**  $i = 1$  to  $max$  Gibbs sampling iterations **do**
  - 3:   **for** all documents  $d \in [1, M]$  **do**
  - 4:     **for** all words  $t \in [1, N_d]$  **do**
  - 5:       Exclude word  $t$  associated with sentiment label  $l$  and topic label  $z$  from variables  $N_{k,j,i}, N_{k,j}, N_{d,k,j}, N_{d,k}$  and  $N_d$ ;
  - 6:       Sample a new sentiment-topic pair  $\tilde{l}$  and  $\tilde{z}$  using Equation 6;
  - 7:       Update variables  $N_{k,j,i}, N_{k,j}, N_{d,k,j}, N_{d,k}$  and  $N_d$  using the new sentiment label  $l$  and topic label  $\tilde{z}$ ;
  - 8:     **end for**
  - 9:   **end for**
  - 10:   **for** every 25 iterations **do**
  - 11:     Update hyperparameter  $\alpha$  with the maximum-likelihood estimation;
  - 12:   **end for**
  - 13:   **for** every 100 iterations **do**
  - 14:     Update the matrix  $\Phi$ ,  $\Theta$ , and  $\Pi$  with new sampling results;
  - 15:   **end for**
  - 16: **end for**
- 

full conditional posterior for  $z_t$  and  $l_t$  by marginalizing out the random variables  $\varphi, \theta$ , and  $\pi$

$$P(z_t = j, l_t = k | \mathbf{w}, \mathbf{z}^{-t}, \mathbf{I}^{-t}, \alpha, \beta, \gamma) \propto \frac{N_{j,k,w_t}^{-t} + \beta}{N_{j,k}^{-t} + V\beta} \cdot \frac{N_{d,j,k}^{-t} + \gamma}{N_{d,j}^{-t} + S\gamma} \cdot \frac{N_{d,j}^{-t} + \alpha_j}{N_d^{-t} + \sum_j \alpha_j}. \quad (11)$$

As we do not have a direct per-document sentiment distribution in Reverse-JST, a distribution over sentiment labels for document  $P(\mathbf{l}|d)$  is calculated based on the topic specific sentiment distribution  $\pi$  and the per-document topic proportion  $\theta$ .

$$P(\mathbf{l}|d) = \sum_z P(\mathbf{l}|z, d)P(z|d) \quad (12)$$

## 4 EXPERIMENTAL SETUP

### 4.1 Datasets Description

Two publicly available datasets, the MR and MDS datasets, were used in our experiments. The MR dataset has become a benchmark for many studies since the work of Pang *et al.* [3]. The version 2.0 used in our experiment consists of 1000 positive and 1000 negative movie reviews crawled from the IMDB movie archive, with an average of 30 sentences in each document. We also experimented with another dataset, namely *subjective MR*, by removing the sentences that do not bear opinion information from the MR dataset, following the

approach of Pang and Lee [4]. The resulting dataset still contains 2000 documents with a total of 334,336 words and 18,013 distinct terms, about half the size of the original MR dataset without performing subjectivity detection.

First used by Blitzer *et al.* [7], the MDS dataset contains 4 different types of product reviews clawed from Amazon.com including Book, DVD, Electronics and Kitchen, with 1000 positive and 1000 negative examples for each domain<sup>4</sup>.

Preprocessing was performed on both of the datasets. Firstly, punctuation, numbers, non-alphabet characters and stop words were removed. Secondly, standard stemming was performed in order to reduce the vocabulary size and address the issue of data sparseness. Summary statistics of the datasets before and after preprocessing is shown in Table 1.

### 4.2 Defining Model Priors

In the experiments, two subjectivity lexicons, namely the MPQA<sup>5</sup> and the appraisal lexicons<sup>6</sup>, were combined and incorporated as prior information into the model learning. These two lexicons contain lexical words whose polarity orientation have been fully specified. We extracted the words with strong positive and negative orientation and performed stemming in the preprocessing. In addition, words whose polarity changed after stemming were removed automatically, resulting in 1584 positive and 2612 negative words, respectively. It is worth noting that the lexicons used here are fully domain-independent and do not bear any supervised information specifically to the MR, subjMR and MDS datasets. Finally, the prior information was produced by retaining all words in the MPQA and appraisal lexicons that occurred in the experimental datasets. The prior information statistics for each dataset is listed in Table 2. It can be observed that the prior positive words occur much more frequently than the negative words with its frequency at least doubling that of negative words in all of the datasets.

### 4.3 Hyperparameter Settings

Previous study has shown that while LDA can produce reasonable results with a simple symmetric Dirichlet prior, an asymmetric prior over the document-topic distributions has substantial advantage over a symmetric prior [25]. In the JST model implementation, we set the symmetric prior  $\beta = 0.01$  [22], the symmetric prior  $\gamma = (0.05 \times L)/S$ , where  $L$  is the average document length,  $S$  the is total number of sentiment labels, and the value of 0.05 on average allocates 5% of probability mass for mixing. The asymmetric prior  $\alpha$  is learned

4. We did not perform subjectivity detection on the MDS dataset since its average document length is much shorter than that of the MR dataset, with some documents even containing one sentence only.

5. <http://www.cs.pitt.edu/mpqa/>

6. [http://lingcog.iit.edu/arc/appraisal\\_lexicon\\_2007b.tar.gz](http://lingcog.iit.edu/arc/appraisal_lexicon_2007b.tar.gz)

TABLE 1  
Dataset statistics. Note: †denotes before preprocessing and \* denotes after preprocessing.

Dataset	# of words					
	MR	subjMR	MDS			
			Book	DVD	Electronics	Kitchen
Average doc. length†	666	406	176	170	110	93
Average doc. length*	313	167	116	113	75	63
Vocabulary size†	38,906	34,559	22,028	21,424	10,669	9,525
Vocabulary size*	25,166	18,013	19,428	20,409	9,893	8,512

TABLE 2  
Prior information statistics.

Prior lexicon (pos./neg.)	MR	subjMR	MDS			
			Book	DVD	Electronics	Kitchen
No. of distinct words	1,248/1,877	1,150/1,667	1,008/1,360	987/1320	571/555	595/514
Total occurrence	108,576/57,744	67,751/34,276	31,697/14,006	31,498/13,935	19,599/6,245	18,178/6,099
Coverage (%)	17/9	20/10	13/6	14/6	13/4	14/5

directly from data using maximum-likelihood estimation [26] and updated every 25 iterations during the Gibbs sampling procedure. In terms of Reverse-JST, we set the symmetric  $\beta = 0.01$ ,  $\gamma = (0.05 \times L)/(T \times S)$ , and the asymmetric prior  $\alpha$  is also learned from data as in JST.

#### 4.4 Classifying Document Sentiment

The document sentiment is classified based on  $P(1|d)$ , the probability of sentiment label given document. In our experiments, we only consider the probability of positive and negative label given document, with the neutral label probability being ignored. There are two reasons. First, sentiment classification for both the MR and MDS datasets is effectively a binary classification problem, i.e., documents are being classified either as positive or negative, without the alternative of neutral. Second, the prior information we incorporated merely contributes to the positive and negative words, and consequently there will be much more influence on the probability distribution of positive and negative label given document, rather than the distribution of neutral label given document. Therefore, we define that a document  $d$  is classified as a positive-sentiment document if its probability of positive sentiment label given document  $P(l_{pos}|d)$ , is greater than its probability of negative sentiment label given document  $P(l_{neg}|d)$ , and vice versa.

## 5 EXPERIMENTAL RESULTS

In this section, we present and discuss the experimental results of both document-level sentiment classification and topic extraction, based on the MR and MDS datasets.

### 5.1 Sentiment Classification Results vs. Number of Topics

As both JST and Reverse-JST model sentiment and mixture of topics simultaneously, it is therefore worth ex-

ploring how the sentiment classification and topic extraction tasks affect/benefit each other and in addition, how these two models behave with different topic number settings on different datasets when prior information is incorporated. With this in mind, we conducted a set of experiments on JST and Reverse-JST, with topic number  $T \in \{1, 5, 10, 15, 20, 25, 30\}$ . It is worth noting that as JST models the same number of topics under each sentiment label, therefore with three sentiment labels, the total topic number of JST will be equivalent to a standard LDA model with  $T \in \{3, 15, 30, 45, 60, 75, 90\}$ .

Figure 2 shows the sentiment classification results of both JST and Reverse-JST at document-level by incorporating prior information extracted from the MPQA and appraisal lexicons. For all the reported results, accuracy is used as performance measure and the results were averaged over 10 runs. The baseline is calculated by counting the overlap of the prior lexicon with the training corpus. If the positive sentiment word count is greater than that of the negative words, a document is classified as positive, and vice versa. The improvement over this baseline will reflect how much JST and Reverse-JST can learn from data.

As can be seen from Figure 2 that, both JST and Reverse-JST have a significant improvement over the baseline in all of the datasets. When the topic number is set to 1, both JST and Reverse-JST essentially become the standard LDA model with only three sentiment topics, and hence ignores the correlation between sentiment labels and topics. Figure 2(c), 2(d) and 2(f) show that, both JST and Reverse-JST perform better with multiple topic settings in the Book, DVD and Kitchen domains, especially noticeable for JST with 10% improvement at  $T = 15$  over single topic setting on the DVD domain. This observation shows that modelling sentiment and topics simultaneously indeed help improve sentiment classification. For the cases where single topic performs the best (i.e., Figure 2(a), 2(b) and 2(e)), it is observed that

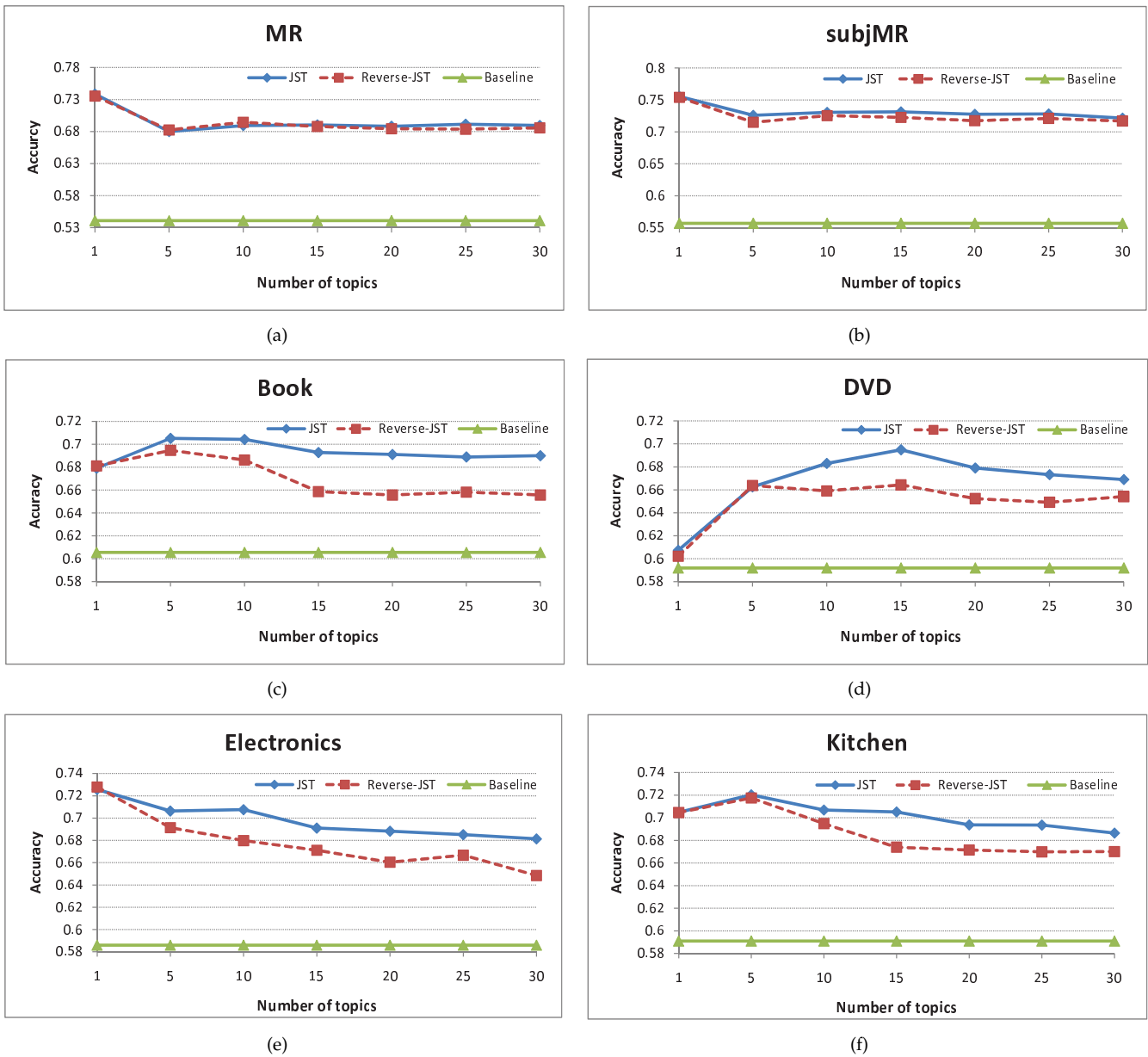

Fig. 2. Sentiment classification accuracy VS. different topic number settings.

apart from the MR dataset, the drop in sentiment classification accuracy by additionally modelling mixture of topics is only marginal (i.e., 1% and 2% point drop in subjMR and Electronics, respectively), but both JST and Reverse-JST are able to extract sentiment-oriented topics in addition to document-level sentiment detection.

When comparing JST with Reverse-JST, there are three observations: (1) JST outperforms Reverse-JST in most of the datasets with multiple topic settings, with up to 4% difference in the Book domain; (2) the performance difference between JST and Reverse-JST has some correlation with the corpus size (cf. Table 1). That is when the corpus size is large, these two models perform almost the same, e.g., on the MR dataset. In contrast, when the corpus size is relatively small, JST significantly outperforms Reverse-JST, e.g., on the MDS dataset. A significance

measure based on paired  $t$ -Test (critical  $P = 0.05$ ) is reported in Table 3 ; (3) for both models, the sentiment classification accuracy is less affected by topic number settings when the dataset size is large. For instance, classification accuracy stays almost the same for the MR and subjMR datasets when topic number is increased from 5 to 30, whereas in contrast, 2-3% drop is observed for Electronics and Kitchen. By closely examining the posterior of JST and Reverse-JST (cf. Equation 6 and 11), we noticed that the count  $N_{d,j}$  (number of times topic  $j$  associated with some word tokens in document  $d$ ) in the Reverse-JST posterior would be relatively small due to the factor of a large topic number setting. On the contrary, the count  $N_{d,k}$  (number of times sentiment label  $k$  assigned to some word tokens in document  $d$ ) in the JST posterior would be relatively large as  $k$  is only defined



TABLE 3

Significant test results. Note: blank denotes the performance of JST and Reverse-JST is significantly undistinguishable; \* denotes JST significantly outperforms Reverse-JST.

T	MR	subjMR	Book	DVD	Electronics	Kitchen
5						
10				*		
15			*	*	*	*
20			*	*	*	*
25	*		*	*	*	*
30			*	*	*	

over 3 different sentiment labels. This essentially makes JST less sensitive to the data sparseness problem and the perturbation of hyperparameter settings. In addition, JST encodes the assumption that there is approximately a single sentiment for the entire document, i.e., documents are mostly either positive or negative. This assumption is important as it allows the model to cluster different terms which share similar sentiment. In Reverse-JST, this assumption is not enforced unless only one topic for each sentiment label is defined. Therefore, JST appears to be a more appropriate model design for joint sentiment topic detection.

## 5.2 Comparison with Existing Models

In this section, we compare the overall sentiment classification performance of JST, Reverse-JST with some existing semi-supervised approaches [19], [27]. As can be seen from Table 4 that, the baseline results calculated based on the sentiment lexicon are below 60% for most of the datasets. By incorporating the same prior lexicon, a significant improvement is observed for JST and Reverse-JST over the baseline, where both models have over 20% performance gain on the MR and subjMR datasets, and 10-14% improvement on the MDS dataset. For the movie review data, there is a further 2% improvement for both models on the subjMR dataset over the original MR dataset. This suggests that though the subjMR dataset is in a much compressed form, it is more effective than the full dataset as it retains comparable polarity information in a much cleaner way [4]. In terms of the MDS dataset, both JST and Reverse-JST perform better on Electronics and Kitchen than Book and DVD, with about 2% difference in accuracy. Manually analyzing the MDS dataset reveals that the book and DVD reviews often contain a lot of descriptions of book contents or movie plots, which makes the reviews of these two domains difficult to classify; in contrast, in Electronics and Kitchen, comments on products are often expressed in a much more straightforward manner. In terms of the overall performance, except in Electronics, it was observed that JST performed slightly better than Reverse-JST in all sets of experiments, with differences of 0.2-3% being observed.

When compared to the recently proposed weakly-supervised approach based on a spectral clustering algorithm [27], except slightly lower in the DVD domain,

JST achieved better performance in all the other domains with more than 3% overall improvement. Nevertheless, the proposed approach [27] requires users to specify which dimensions (defined by the eigenvectors in spectral clustering) are most closely related to sentiment by inspecting a set of features derived from the reviews for each dimension, and clustering is performed again on the data to derive the final results. In contrast, for the JST and Reverse-JST models proposed here, no human judgement is required. Another recently proposed non-negative matrix tri-factorization approach [19] also employed lexical prior knowledge for semi-supervised sentiment classification. However, when incorporating 10% of labelled documents for training, the non-negative matrix tri-factorization approach performed much worse than JST, with only around 60% accuracy being achieved for all the datasets. Even with 40% labelled documents, it still performs worse than JST on the MR dataset and only slightly outperforms JST on the MDS dataset. It is worth noting that no labelled documents were used in the JST results reported here.

## 5.3 Sentiment Classification Results with Different Features

While JST and Reverse-JST models can give better or comparative performance in document-level sentiment classification compared to semi-supervised approaches [19], [27] with unigram features, it is worth considering the dependency between words since it might serve an important function in sentiment analysis. For instance, phrases expressing negative sentiment such as “not good” or “not durable” will convey completely different polarity meaning without considering negations. Therefore, we extended the JST and Reverse-JST models to include higher order information, i.e., bigrams, for model learning. Table 5 shows the feature statistics of the datasets in unigrams, bigrams and the combination of both. For the negator lexicon, we collect a handful of words from the General Inquirer under the NOTLW category<sup>7</sup>. We experimented with topic number  $T \in \{1, 5, 10, 15, 20, 25, 30\}$ . However, it was found that JST and Reverse-JST achieved best results with single topic on bigrams and the combination of bigrams and unigrams most of the time, except a few cases where

7. <http://www.wjh.harvard.edu/~inquirer/NotLw.html>

TABLE 4  
Performance comparison with existing models. (Note: boldface denotes the best results.)

	Accuracy (%)							
	MR	subjMR	MDS					MDS overall
			Book	DVD	Electronics	Kitchen		
Baseline	54.1	55.7	60.6	59.2	58.6	59.1	59.4	
JST	<b>73.9</b>	<b>75.6</b>	<b>70.5</b>	<b>69.5</b>	72.6	<b>72.1</b>	<b>71.2</b>	
Reverse-JST	73.5	75.4	69.5	66.4	<b>72.8</b>	71.7	70.1	
Dasgupta and Ng (2009)	70.9	N/A	69.5	70.8	65.8	69.7	68.9	
Li et al.(2009) with 10% doc. label	60	N/A			N/A		62	
Li et al.(2009) with 40% doc. label	73.5	N/A					73	

TABLE 5  
Unigram and bigram features statistics.

Dataset	# of features (Unit: thousand)						
	MR	subjMR	MDS				
			Book	DVD	Electronics	Kitchen	
unigrams	626	334	232	226	150	126	
bigrams	1,239	680	318	307	201	170	
unigrams+bigrams	1,865	1,014	550	533	351	296	

TABLE 6  
Sentiment classification results with different features. Note: boldface denotes the best results.

	Accuracy(%)					
	JST			Reverse-JST		
	unigrams	bigrams	unigrams+bigrams	unigrams	bigrams	unigrams+bigrams
MR	73.9	74	<b>76.6</b>	73.5	74.1	76.6
subjMR	75.6	75.6	<b>77.7</b>	75.4	75.5	77.6
Book	70.5	70.3	<b>70.8</b>	69.5	69.7	69.8
DVD	69.5	71.3	<b>72.5</b>	66.4	71.4	72.4
Electronics	72.6	70.2	74.9	72.8	70.5	<b>75</b>
Kitchen	<b>72.1</b>	70	70.8	71.7	69.9	70.5

multiple topics perform better (i.e., JST and Reverse-JST with  $T = 5$  on Book using unigrams+bigrams, as well as Reverse-JST with  $T = 10$  on Electronics using unigrams+bigrams). This is probably due to the fact that bigrams features have much lower frequency counts than unigrams. Thus, with the sparse feature co-occurrence, multiple topic settings likely fail to cluster different terms that share similar sentiment and hence harm the sentiment classification accuracy.

Table 6 shows the sentiment classification results of JST and Reverse-JST with different features being used. It can be observed that both JST and Reverse-JST perform almost the same with unigrams or bigrams on the MR, subjMR, and Book datasets. However, using bigrams gives a better accuracy in DVD but is worse on Electronics and Kitchen compared to using unigrams for both models. When combining both unigrams and bigrams, a performance gain is observed for most of the datasets except the Kitchen data. For both MR and subjMR, using the combination of unigrams and bigrams gives more than 2% improvement compared to using either unigrams or bigrams alone, with 76.6% and 77.7% accuracy being achieved on these two datasets, respectively. For the MDS dataset, the combined features slightly outperforms unigrams and bigrams on Book and gives a significant gain on DVD (i.e., 3% over unigrams; 1.2%

over bigrams) and Electronics (i.e., 2.3% over unigrams; 4.7% over bigrams). Thus, we may conclude that the combination of unigrams and bigrams gives the best overall performance.

#### 5.4 Topic Extraction

The second goal of JST is to extract topics from the MR (without subjectivity detection) and MDS datasets, and evaluate the effectiveness of topic sentiment captured by the model. Unlike the LDA model where a word is drawn from the topic-word distribution, in JST one draws a word from the per-corpus word distribution conditioned on both topics and sentiment labels. Therefore, we analyze the extracted topics under positive and negative sentiment label, respectively. 20 topic examples extracted from the MR and MDS datasets are shown in Table 7, where each topic was drawn from a particular domain under a sentiment label.

Topics on the top half of Table 7 were generated under the positive sentiment label and the remaining topics were generated under the negative sentiment label, each of which is represented by the top 15 topic words. As can be seen from the table that the extracted topics are quite informative and coherent. The movie review topics try to capture the underlying theme of a movie or the relevant comments from a movie reviewer, while

TABLE 7  
Topic examples extracted by JST under different sentiment labels.

	MR	Book	DVD	Electronics	Kitchen					
Positive sentiment label	ship	good	recip	children	action	funni	mous	sound	color	recommend
	titan	realli	food	learn	good	comedi	hand	qualiti	beauti	highli
	crew	plai	cook	school	fight	make	logitech	stereo	plate	impress
	cameron	great	cookbook	child	right	humor	comfort	good	durabl	love
	alien	just	beauti	ag	scene	laugh	scroll	high	qualiti	favorit
	jack	perform	simpl	parent	chase	charact	wheel	listen	fiestawar	especi
	water	nice	eat	student	hit	joke	smooth	volum	blue	nice
	stori	fun	famili	teach	art	peter	feel	decent	finger	beautifulli
	rise	lot	ic	colleg	martial	allen	accur	music	white	absolut
	rose	act	kitchen	think	stunt	entertain	track	hear	dinnerwar	fabul
	boat	direct	variety	young	chan	funniest	touch	audio	bright	bargin
	deep	best	good	cours	brilliant	sweet	click	set	purpl	valu
	ocean	get	pictur	educ	hero	constantli	conveni	price	scarlet	excel
	dicaprio	entertain	tast	kid	style	accent	month	speaker	dark	bought
	sink	better	cream	english	chines	happi	mice	level	eleg	solid
	Negative sentiment label	prison	bad	polit	war	horror	murder	drive	batteri	fan
evil		worst	east	militari	scari	killer	fail	charg	room	order
guard		plot	middl	armi	bad	cop	data	old	cool	return
green		stupid	islam	soldier	evil	crime	complet	life	air	ship
hank		act	unit	govern	dead	case	lose	unaccept	loud	sent
wonder		suppos	inconsist	thing	blood	prison	failur	charger	nois	refund
excute		script	democrat	evid	monster	detect	recogn	period	live	receiv
secret		wast	influenc	led	zombi	investig	backup	longer	annoi	damag
mile		dialogu	politician	iraq	fear	mysteri	poorli	recharg	blow	dissappoint
death		bore	disput	polic	scare	commit	error	hour	vornado	websit
base		poor	cultur	destruct	live	thriller	storag	last	bedroom	discount
tom		complet	eastern	critic	ghost	attorney	gb	power	inferior	polic
convict		line	polic	inspect	devil	undercov	flash	bui	window	unhappi
return		terribl	state	invas	head	suspect	disast	worthless	vibrat	badli
franklin		mess	understand	court	creepi	shock	yesterdai	realli	power	shouldn

the topics from the MDS dataset represent a certain product review from the corresponding domain. For example, for the two positive sentiment topics under the movie review domain, the first is closely related to the very popular romantic movie “Titanic” directed by James Cameron and casted by Leonardo DiCaprio and Kate Winslet, whereas the other one is likely to be a positive review for a movie. Regarding the MDS dataset, the first topic of Book and DVD under the positive sentiment label probably discusses a good cookbook and a popular action movie by Jackie Chan, respectively; for the first negative topic of Electronics, it is likely to be complaints regarding data loss due to the flash drive failure, while the first negative topic of the kitchen domain is probably the dissatisfaction of the high noise level of the *Vornado* brand fan.

In terms of topic sentiment, by examining each of the topics in Table 7, it is quite evident that most of the positive and negative topics indeed bear positive and negative sentiment, respectively. The first movie review topic and the second Book topic under the positive sentiment label mainly describes movie plot and the contents of a book, with less words carrying positive sentiment compared to other positive sentiment topics under the same domain. Manually examining the data reveals that the terms that seem not conveying sentiments under the topic in fact appears in the context expressing positive sentiments. Overall, the above analysis illustrates the effectiveness of JST in extracting opinionated topics from a corpus.

## 6 CONCLUSIONS AND FUTURE WORK

In this paper, we presented a joint sentiment-topic (JST) model and a reparameterized version of JST called Reverse-JST. While most of the existing approaches to sentiment classification favor in supervised learning, both JST and Reverse-JST models target sentiment and topic detection simultaneously in a weakly-supervised fashion. Without hierarchical prior, JST and Reverse-JST are essentially equivalent. However, extensive experiments conducted on datasets across different domains reveal that, these two models behave very differently when sentiment prior knowledge is incorporated, where JST consistently outperformed Reverse-JST. For general domain sentiment classification, by incorporating a small amount of domain-independent prior knowledge, the JST model achieved either better or comparable performance compared to existing semi-supervised approaches despite using no labelled documents, which demonstrates the flexibility of JST in the sentiment classification task. Moreover, the topics and topic sentiments detected by JST are indeed coherent and informative.

There are several directions we plan to investigate in the future. One is incremental learning of the JST parameters when facing with new data. Another one is the modification of the JST model with other supervised information being incorporated into JST model learning, such as some known topic knowledge for certain product reviews or document labels derived automatically from the user supplied review ratings.

## ACKNOWLEDGMENTS

We would like to thank the anonymous reviewers for their valuable comments.

## REFERENCES

- [1] B. Pang and L. Lee, "Opinion mining and sentiment analysis," *Found. Trends Inf. Retr.*, vol. 2, no. 1-2, pp. 1-135, 2008.
- [2] P. D. Turney, "Thumbs up or thumbs down?: semantic orientation applied to unsupervised classification of reviews," in *Proceedings of ACL*, 2001, pp. 417-424.
- [3] B. Pang, L. Lee, and S. Vaithyanathan, "Thumbs up?: sentiment classification using machine learning techniques," in *Proceedings of EMNLP*, 2002, pp. 79-86.
- [4] B. Pang and L. Lee, "A sentimental education: sentiment analysis using subjectivity summarization based on minimum cuts," in *Proceedings of ACL*, 2004, p. 271.
- [5] C. Whitelaw, N. Garg, and S. Argamon, "Using appraisal groups for sentiment analysis," in *Proceedings of CIKM*, 2005.
- [6] A. Kennedy and D. Inkpen, "Sentiment classification of movie reviews using contextual valence shifters," *Computational Intelligence*, vol. 22, no. 2, pp. 110-125, 2006.
- [7] J. Blitzer, M. Dredze, and F. Pereira, "Biographies, bollywood, boom-boxes and blenders: Domain adaptation for sentiment classification," in *Proceedings of ACL*, 2007, pp. 440-447.
- [8] A. Aue and M. Gamon, "Customizing sentiment classifiers to new domains: a case study," in *Proceedings of RANLP*, 2005.
- [9] C. Lin and Y. He, "Joint sentiment/topic model for sentiment analysis," in *Proceedings of CIKM*, 2009.
- [10] D. M. Blei, A. Y. Ng, and M. I. Jordan, "Latent Dirichlet allocation," *J. Mach. Learn. Res.*, vol. 3, pp. 993-1022, 2003.
- [11] Q. Mei, X. Ling, M. Wondra, H. Su, and C. Zhai, "Topic sentiment mixture: modeling facets and opinions in weblogs," in *Proceedings of WWW*, 2007, pp. 171-180.
- [12] I. Titov and R. McDonald, "A joint model of text and aspect ratings for sentiment summarization," in *Proceedings of ACL-HLT*, 2008, pp. 308-316.
- [13] S. Hayakawa and E. Ehrlich, *Choose the right word: A contemporary guide to selecting the precise word for every situation*. Proceedings of Collins, 1994.
- [14] S. Li and C. Zong, "Multi-domain sentiment classification," in *Proceedings of ACL-HLT*, 2008, pp. 257-260.
- [15] R. McDonald, K. Hannan, T. Neylon, M. Wells, and J. Reynar, "Structured models for fine-to-coarse sentiment analysis," in *Proceedings of ACL*, 2007, pp. 432-439.
- [16] A. Abbasi, H. Chen, and A. Salem, "Sentiment analysis in multiple languages: Feature selection for opinion classification in web forums," *ACM Trans. Inf. Syst.*, vol. 26, no. 3, pp. 1-34, 2008.
- [17] N. Kaji and M. Kitsuregawa, "Automatic construction of polarity-tagged corpus from html documents," in *Proceedings of COLING/ACL*, 2006, pp. 452-459.
- [18] A. Andreevskaia and S. Bergler, "When specialists and generalists work together: Overcoming domain dependence in sentiment tagging," in *Proceedings of ACL-HLT*, 2008, pp. 290-298.
- [19] T. Li, Y. Zhang, and V. Sindhwani, "A non-negative matrix tri-factorization approach to sentiment classification with lexical prior knowledge," in *Proceedings of ACL-IJCNLP*, 2009, pp. 244-252.
- [20] I. Titov and R. McDonald, "Modeling online reviews with multi-grain topic models," in *Proceedings of WWW*, 2008.
- [21] T. Hofmann, "Probabilistic latent semantic indexing," in *Proceedings of SIGIR*, 1999, pp. 50-57.
- [22] M. Steyvers and T. Griffiths, "Probabilistic Topic Models," *Handbook of Latent Semantic Analysis*, p. 427, 2007.
- [23] S. Lacoste-Julien, F. Sha, and M. Jordan, "DiscLDA: Discriminative learning for dimensionality reduction and classification," in *Proceedings of NIPS*, 2008.
- [24] D. Ramage, D. Hall, R. Nallapati, and C. Manning, "Labeled LDA: A supervised topic model for credit attribution in multi-labeled corpora," in *Proceedings of EMNLP*, 2009, pp. 248-256.
- [25] H. Wallach, D. Mimno, and A. McCallum, "Rethinking LDA: Why priors matter," in *Topic Models: Text and Beyond Workshop in Neural Information Processing Systems Conference*, 2009.

- [26] T. Minka, "Estimating a Dirichlet distribution," MIT, Tech. Rep., 2003.
- [27] S. Dasgupta and V. Ng, "Topic-wise, Sentiment-wise, or Other-wise? Identifying the Hidden Dimension for Unsupervised Text Classification," in *Proceedings of EMNLP*, 2009, pp. 580-589.

PLACE  
PHOTO  
HERE

**Chenghua Lin** is currently a PhD student in Computer Science, College of Engineering, Mathematics and Physical Sciences at the University of Exeter. He received his BEng degree in Electrical Engineering and Automation from Beihang University in 2006, China, and MEng degree (1st class Honors) in Electronic Engineering from the University of Reading in 2007, UK. His research interests are sentiment analysis of web data using machine learning and statistical methods.

PLACE  
PHOTO  
HERE

**Yulan He** received the BSc (1st class Honors) and MEng degrees in Computer Engineering from Nanyang Technological University, Singapore, in 1997 and 2001, respectively, and the PhD degree in 2004 from Cambridge University Engineering Department, UK. She is currently a Senior Lecturer at the Knowledge Media Institute of the Open University, UK. Her early research focused on spoken language understanding, biomedical literature mining, and microarray data analysis. Her current research interests lie in the integration of machine learning and natural language processing for sentiment analysis and information extraction from the Web.

interests lie in the integration of machine learning and natural language processing for sentiment analysis and information extraction from the Web.

PLACE  
PHOTO  
HERE

**Richard Everson** graduated with a degree in Physics from Cambridge University in 1983 and a PhD in Applied Mathematics from Leeds University in 1988. He worked at Brown and Yale Universities on fluid mechanics and data analysis problems until moving to Rockefeller University, New York to work on optical imaging and modelling of the visual cortex. After working at Imperial College, London, he joined the Computer Science department at Exeter University where he is now an Associate Professor of Machine Learning. Current research interests are in statistical pattern recognition, multi-objective optimisation and the links between them.

Machine Learning. Current research interests are in statistical pattern recognition, multi-objective optimisation and the links between them.

PLACE  
PHOTO  
HERE

**Stefan Ruger** (Dr rer nat Dipl-Phys FHEA MACM MBCS) joined The Open University's Knowledge Media Institute in 2006 to take up a chair in Knowledge Media and head a research group working on Multimedia Information Retrieval. Before that he was a Reader in Multimedia and Information Systems at the Department of Computing, Imperial College London, where he also held an EPSRC Advanced Research Fellowship (1999-2004). Rger is a theoretical physicist by training (FU Berlin) and received his

PhD in the field of computing for his work on artificial intelligence and, in particular, the theory of neural networks from TU Berlin in 1996. For further information and publications see <http://kmi.open.ac.uk/mmis>.