

Interocular transfer of spatial adaptation is weak at low spatial frequencies

Daniel H. Baker & Tim S. Meese

School of Life & Health Sciences, Aston University, Birmingham, B4 7ET, UK
email: d.h.baker1@aston.ac.uk

Abstract

Adapting one eye to a high contrast grating reduces sensitivity to similar target gratings shown to the same eye, and also to those shown to the opposite eye. According to the textbook account, interocular transfer (IOT) of adaptation is around 60% of the within-eye effect. However, most previous studies on this were limited to using high spatial frequencies, sustained presentation, and criterion-dependent methods for assessing threshold. Here, we measure IOT across a wide range of spatiotemporal frequencies, using a criterion-free 2AFC method. We find little or no IOT at low spatial frequencies, consistent with other recent observations. At higher spatial frequencies, IOT was present, but weaker than previously reported (around 35%, on average, at 8c/deg). Across all conditions, monocular adaptation raised thresholds by around a factor of 2, and observers showed normal binocular summation, demonstrating that they were not binocularly compromised. These findings prompt a reassessment of our understanding of the binocular architecture implied by interocular adaptation. In particular, the output of monocular channels may be available to perceptual decision making at low spatial frequencies.

Keywords: adaptation, interocular transfer, dichoptic, spatial frequency, temporal frequency

1 Introduction

Most biological sensory systems exhibit adaptation (desensitization) effects when stimulated for an extended period. In the human visual system, sensitivity to a sine-wave grating stimulus is reduced following adaptation to a high contrast grating of similar orientation and spatial frequency (Blakemore & Campbell, 1969). This observation played an important role in establishing the idea that the visual system processes inputs in multiple spatial 'channels', akin to a crude Fourier analysis (Graham, 1989). A channel, or bandpass filter, becomes fatigued by the adaptor and is subsequently less responsive to other stimuli within its pass band, causing elevation of detection thresholds for a range of targets similar to the adaptor (see Meese & Holmes (2002) and Webster (2011) for further details on adaptation).

Another important finding was that adaptation aftereffects transfer between the eyes – adapting one eye causes threshold elevation in

the other eye. The magnitude of the transfer is typically reported to be around 60% (Blakemore & Campbell, 1969), implying that the majority of the adaptation is occurring after the point at which information from the eyes is combined (i.e. in binocular neurones). In other paradigms, such as adaptation to motion, transfer as high as 100% has been reported (Nishida, Ashida, & Sato, 1994), though it is typically lower (Wade, Swanson, & de Weert, 1993). Interocular transfer (IOT) is defined as the ratio of dichoptic to monocular threshold elevations, usually expressed as a percentage: $IOT = 100 * (TE_{dich} / TE_{mon})$, where TE represents threshold elevation in logarithmic units (Snowden & Hammett, 1996; Bjørklund & Magnussen, 1981). IOT remains stable across a wide range of adaptor contrasts and adaptation durations (Bjørklund & Magnussen, 1981).

Recently, we (Meese & Baker, 2011) were surprised to find little or no IOT of threshold

elevation for three observers, using a rigorous 2AFC detection task. We reviewed the literature to see if any aspects of our stimulus might have been responsible (we used a low spatial frequency of 0.5c/deg and a high temporal (flicker) frequency of 15Hz). The results of this meta-analysis are shown in Figure 1, and prompt several observations. It is clear that the majority of studies (13/16) were carried out at or above a spatial frequency of 3c/deg, and report interocular transfer in the classical range of around 60%. Only the three more recent studies (Meese & Baker, 2011; Falconbridge, Ware, & MacLeod, 2010; Cass, Johnson, Bex, & Alais, 2012) have focussed on lower spatial frequencies, and these produced weaker interocular transfer, generally below 50% (note that none of these studies were primarily concerned with IOT, and since we calculated the values ourselves from the monocular and dichoptic adaptation

aftereffects this is the first time they have been explicitly reported).

Furthermore, the temporal properties in the older studies were usually sustained (slow): in addition to using static adaptors, targets typically remained on the display continuously for several seconds whilst observers adjusted the contrast to threshold. This means that a substantial region of spatiotemporal space, corresponding to both low spatial and high temporal frequencies, has been neglected by previous studies. In contrast, the three more recent studies all used counterphase flickering (Falconbridge et al., 2010; Cass et al., 2012) or jittering (Meese & Baker, 2011) adaptors of at least 10Hz, introducing a fast temporal component. Interestingly, two early studies on flicker adaptation (Smith, 1971; Hanly & MacKay, 1979) anecdotally report a complete absence of interocular transfer for flickering uniform fields.

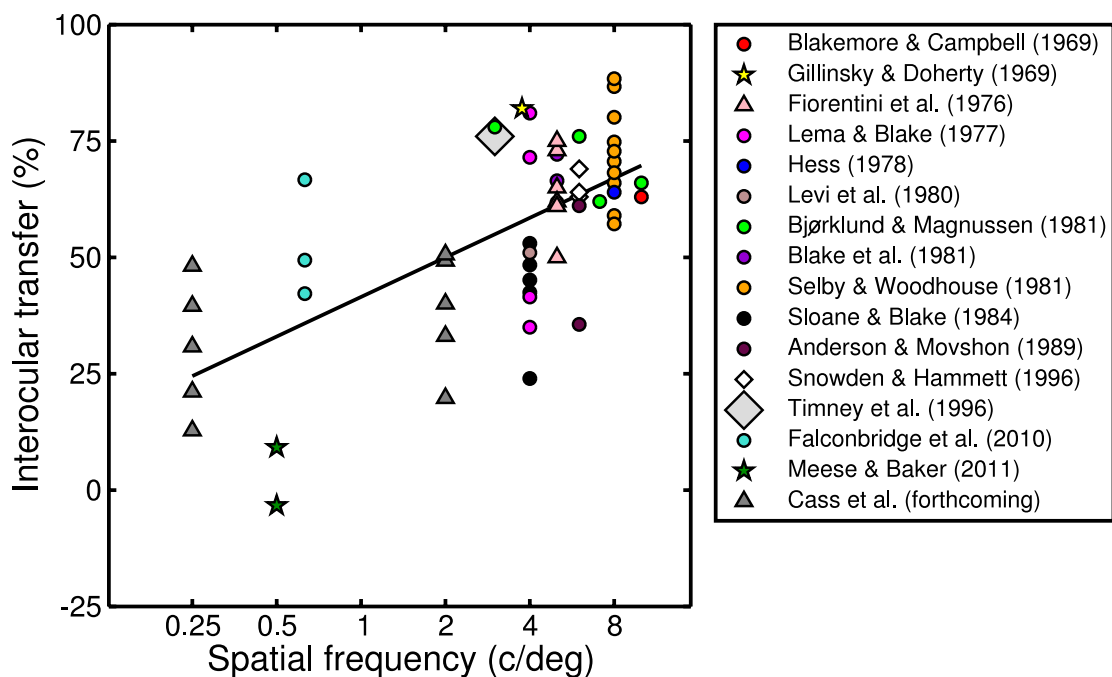

Figure 1: Summary of interocular transfer effects reported by or obtained from previous studies. Symbols indicate the method used in each study: circles are for method of adjustment, stars for 2AFC, diamonds for yes/no and triangles for 4AFC or modified 2AFC. Each datum represents a single observer, except for the large grey diamond, which represents group data for six observers. Selby & Woodhouse (1981) also report IOT at lower spatial frequencies (0.5-2c/deg), but the precise frequencies used for each observer are not clear from their manuscript so we include only their 8c/deg data here. A further observer in the Meese & Baker (2011) study produced IOT of -45% (not shown).

It seems plausible then that both spatial and temporal frequency might determine the level of interocular transfer. In fact, several recent masking studies (Meese & Holmes, 2007; Medina & Mullen, 2009; Meese & Baker, 2009) have reported a strong dependency of masking strength on stimulus speed (the ratio of temporal to spatial frequency). Such a

difference could correspond to distinct populations of neurones (e.g. *M* and *P* cells) that are selective for transient and sustained stimuli (e.g. Merigan, Katz, & Maunsell, 1991). In the context of interocular transfer, it might reveal characteristics of the binocular architectures of the magno (*M*) and parvo (*P*) pathways (Meese & Baker, 2011).

To investigate interocular transfer in greater detail, we measured adaptation aftereffects across a range of spatial and temporal frequencies for nine observers using a 2AFC paradigm. We find a clear dependence on spatial frequency, with our two lowest frequencies producing little or no IOT. There was no significant effect of temporal frequency. This result prompts a reassessment of our understanding of the level(s) of processing at which adaptation takes place.

2 Methods

2.1 Apparatus & stimuli

The target stimuli were horizontal Gabor patches, with spatial frequencies of 0.5, 2 or 8c/deg. They were in \pm sine phase with the centre of the monitor, and had a Gaussian spatial envelope with a full width at half height of 1.67 carrier cycles (at 0.5 and 2c/deg) or 6.68 carrier cycles (at 8c/deg; the larger target was used because pilot work found that thresholds for smaller targets were too high to measure reliably for some observers). Target

location was indicated by a quad of fixation points, which were continuously present. The adaptors had the same spatial frequency and orientation as the targets, but were windowed by a 10° wide raised cosine envelope (8° plateau, 1° blur at each edge). This meant that even if observers made small eye movements during the adapt period, the adaptor would always cover the central target region. An example target and adaptor are shown in Figure 2.

We used three temporal modulation profiles for the target stimuli. The 1Hz modulator was half a cycle of a 1Hz sine wave. The 4Hz modulator was a 4Hz counterphasing sinusoid, multiplied by the 1Hz modulator. The 15Hz modulator was a 15Hz square wave, also multiplied by the 1Hz modulator. Figure 2c illustrates these waveforms. The adapting stimuli were temporally modulated at the same frequencies, but for longer durations, so the 1Hz modulator phase reversed every 500ms, and the two higher frequencies did not have a lower frequency envelope.

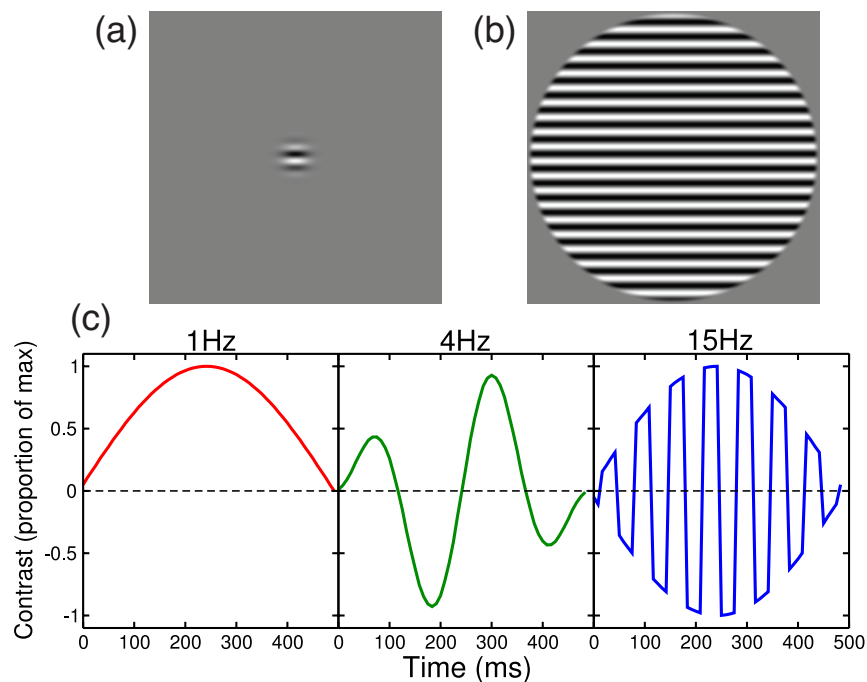

Figure 2: Example stimuli and temporal waveforms. (a) Example target Gabor patch. (b) Adapting grating with the same spatial frequency as the target in (a). (c) Temporal waveforms used to modulate target contrasts. Negative contrasts indicate a phase reversal.

There were three experimental setups: four observers used a ViSaGe stimulus generator, four used a VSG2/5 and one used a VSG2/4 (all stimulus generators were from Cambridge Research Systems, Kent, UK (CRS)). Each setup was controlled by a PC, and used a Clinton Monoray monitor (CRS) viewed

through ferro-electric shutter goggles (CRS, FE-01) to permit control over the eye of presentation. The monitors had a mean luminance of 120cd/m^2 , which was attenuated by a factor of ~ 8 by the goggles. For all setups the goggles were mounted in a head rest at a viewing distance of 1m.

We define target contrast as percent Michelson contrast ($C\% = 100*(L_{max}-L_{min})/(L_{max}+L_{min})$, where L is luminance) in decibels, such that $C_{dB} = 20*\log_{10}(C\%)$.

2.2 Observers

Nine observers took part in the experiment. Two were postdoctoral researchers (including author DHB). The others were undergraduate students, six of whom participated for course credit, and one of whom was paid. Observers wore their standard optical correction if required, and had no known abnormalities of binocular vision.

2.3 Procedure

Factorial combination of the three spatial and three temporal frequencies produced nine experimental conditions. Each observer was allocated a unique set of five of these conditions, with the constraint that they experienced all spatial frequencies for a single temporal frequency, and all temporal frequencies for a single spatial frequency. This design meant that each of the nine conditions was completed by five observers. An illustration of this design is provided in Figure 3. Each of the nine 'Tetris' shapes indicates the conditions performed (shaded squares) by a single observer.

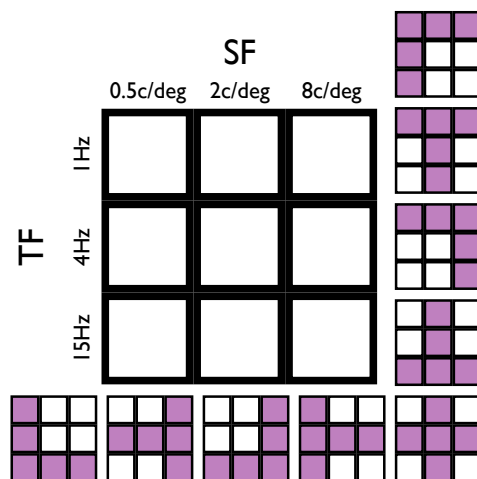

Figure 3: Diagram outlining the design of the experiment and condition allocation. The large grid shows all nine possible spatial and temporal conditions. The smaller grids indicate the subsets of conditions (shaded squares) allocated to each observer (one grid per observer) in no particular order.

Thresholds were measured using a temporal two-alternative forced-choice (2AFC) procedure. The stimulus duration was 500ms (see Figure 2c) with an interstimulus interval

of 400ms. The task was to use mouse buttons to indicate which interval appeared to contain the target (the other interval being blank). Each interval was marked with a beep, and feedback indicated correctness of response. Target contrasts were determined by a pair of 3-down-1-up staircases. We used Probit analysis (Finney, 1971) to estimate thresholds at 75% correct performance.

Observers began by completing a block of baseline sessions for each of their allocated conditions. These blocks measured detection thresholds for each eye with no adaptation. We also measured binocular detection thresholds using stimuli normalized to each eye's detection threshold (see Baker, Meese, Mansouri, & Hess, 2007). This technique compensates for potential eye dominance, and permits measurement of binocular summation by comparison with the monocular thresholds. (Binocular summation is the ratio of binocular to monocular sensitivity, and shows the performance improvement in using two eyes over one). Similar blocks of baselines were also measured at the end of the experiment, after all of the adaptation data had been gathered.

Further baselines were measured using the same procedure for one spatiotemporal condition prior to each adaptation session. Observers then adapted to a single spatiotemporal frequency and eye on a given day. The adaptation regime consisted of two minutes of continuous exposure to a flickering adaptor of 80% contrast, followed by 5 seconds of adaptation between each trial (there was no further adaptation between the two intervals of the trial). There was a post-adapt blank interval of 400ms, followed by target presentation as described above. Observers measured two thresholds for the adapted eye and two for the nonadapted eye on each day.

When the experiment was completed, each observer had contributed four baseline thresholds for each eye, four monocular adaptation thresholds and four dichoptic adaptation thresholds for each of their five spatiotemporal conditions. This took a total of around 15 hours per observer. We averaged thresholds across eye and repetition for the baselines and the adaptation conditions. We calculated threshold elevation effects as the dB difference between adapted and baseline thresholds. Interocular transfer was then calculated as the ratio of dichoptic threshold elevation to monocular threshold elevation, expressed as a percentage (see Introduction).

3 Results

Negative IOT values imply that sensitivity improved after adaptation in the dichoptic condition. Binocular summation was calculated as the dB difference (equivalent to the ratio calculated in linear units) between the monocular and binocular thresholds: $B_{sum} = T_{mon} - T_{bin}$, where T is threshold in dB. On inspecting the individual data consistent trends were apparent, so we chose to average across observers to provide a succinct overview of the data rather than present data for individual observers separately.

We first confirm that monocular adaptation was normal using our paradigm. Adaptation raised thresholds in the adapted eye by 5.7dB on average (a factor of ~ 2) across all observers and spatiotemporal conditions. Plotting the level of monocular threshold elevation as a function of spatial frequency (Figure 4a, filled symbols), temporal frequency (Figure 4b, filled symbols) or speed (TF/SF, Figure 4c) revealed no clear trend. We also present dichoptic threshold elevation data in Figure 4a-c (open symbols). This was clearly much weaker, particularly at the lower spatial frequencies (or high speeds) where it was all but absent.

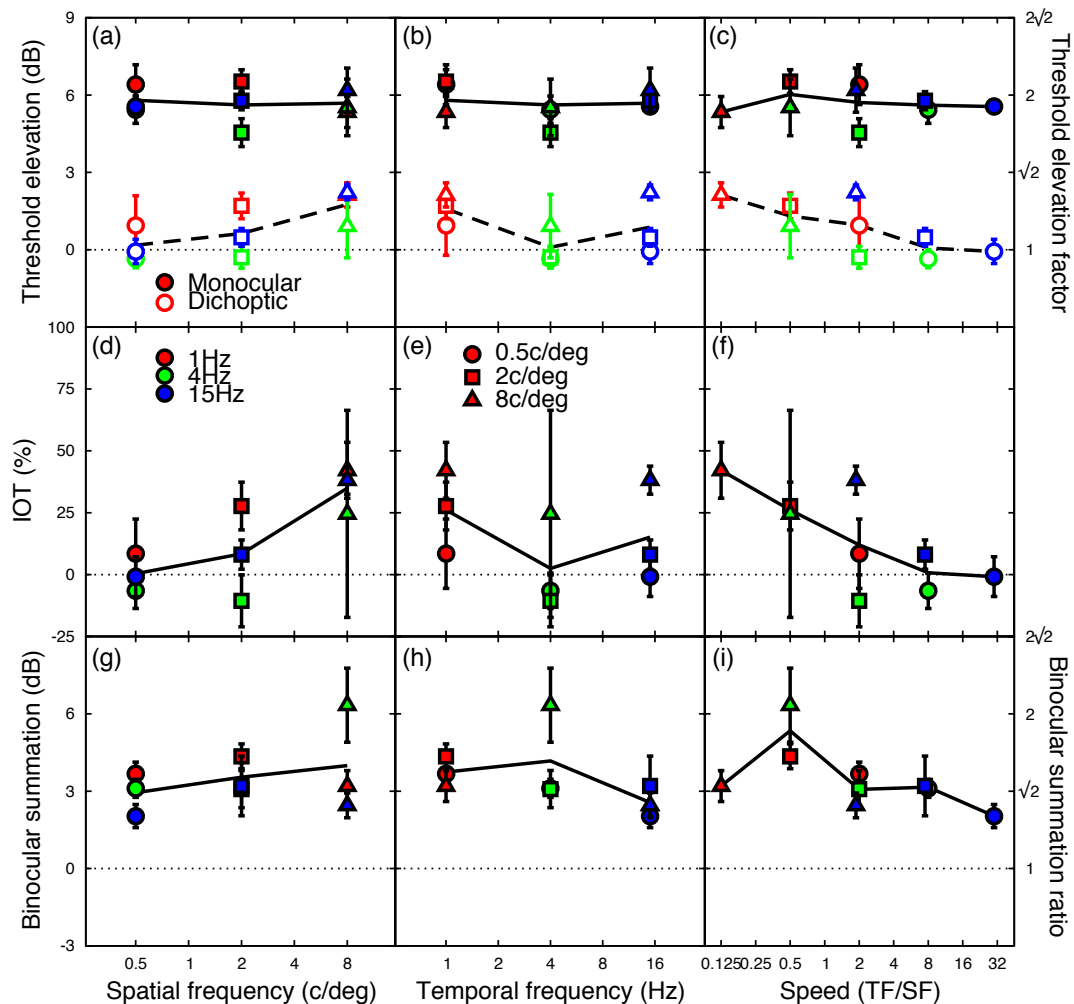

Figure 4: Threshold elevation, interocular transfer and binocular summation results plotted three ways. Monocular (filled symbols) and dichoptic (open symbols) threshold elevation as a function of (a) spatial frequency (SF), (b) temporal frequency (TF), (c) speed (TF/SF). Panels (d,e,f) show interocular transfer, and (g,h,i) show binocular summation as functions of the same three factors. Colours represent different temporal waveforms, consistent with Figure 2c. Error bars are standard errors across observers ($n=5$ per condition), and the black curves indicate the averages (in dB) at each x-value. Note that because we used 15Hz instead of 16Hz, the blue symbols in panels (c,f,i) are offset slightly to the left relative to other symbols nearby, so we pooled across all nearby symbols when calculating the averages.

We used the threshold elevation values to calculate IOT (see Introduction). Overall, the levels of transfer were lower than expected from previous work (mean transfer of 15%). The strongest transfer for any condition was 42% (8c/deg 1Hz, red triangles), somewhat below the ~60% typically reported in the literature (see Figure 1). Two conditions produced negative transfer on average (0.5 and 2c/deg at 4Hz, green circles and squares in Figure 4d-f). This indicates that dichoptic adaptation had a facilitatory effect, i.e. that thresholds improved slightly following adaptation (see Meese & Baker, 2011).

To address whether the level of IOT depends on spatiotemporal parameters, IOT was plotted three ways in Figure 4d-f: as a function of spatial frequency (SF) (Figure 4d), temporal frequency (TF) (Figure 4e) and speed (Figure 4f), where speed = TF/SF (note that speed is a scalar quantity; none of our stimuli drifted). Plotting IOT as a function of spatial frequency (Figure 4d) reveals a clear effect of increasing frequency, qualitatively consistent with the trend in Figure 1. There is some spread in the data at 2c/deg, indicating that the temporal frequency may also influence transfer. Although there was no clear effect of temporal frequency (Figure 4e), replotting as a function of stimulus speed (TF/SF) revealed a marked trend (Figure 4f).

We performed a two-factor ANOVA, with spatial and temporal frequency as the factors, and 5 measures (observers) per condition. Spatial frequency was a significant factor ($F=3.59$, $df=2$, $p<0.05$), whereas temporal frequency was not ($F=1.53$, $df=2$, $p=0.23$). There was no significant interaction ($F=0.16$, $df=4$, $p=0.96$; note that the interaction is not equivalent to considering IOT in terms of stimulus speed (Figure 4f) and we were not able to perform a separate ANOVA on speed because of the unequal number of samples in each condition).

One possibility is that IOT was reduced at low spatial frequencies because our observers were binocularly compromised in some way (e.g. Baker et al., 2007) in this region of stimulus space. To assess this, we calculated binocular summation ratios, a performance measure of binocular function, for unadapted thresholds. Most binocular summation ratios lay between 3 and 6dB (linear ratios of 1.41 and 2), as reported in the classical literature (Campbell & Green, 1965; Legge, 1984). There was a weak increase in summation at higher spatial frequencies (Figure 4g), but this was due

entirely to one outlying point (green triangle), and was not significant in a two-factor ANOVA ($F=0.38$, $df=2$, $p=0.69$). There was a significant effect of temporal frequency ($F=3.85$, $df=2$, $p<0.05$), and it is clear from Figure 4h that summation was weaker at 15Hz.

The mean level of summation across conditions and observers was 3.28dB (i.e. observers were 1.46 times more sensitive binocularly than monocularly). This is lower than the ~4.5dB (ratio of ~1.68) we have found consistently in other studies (e.g. Meese et al, 2006) using stimuli with less transient temporal properties. It seems likely that the temporal frequency effect identified above is responsible for this discrepancy. A preliminary report of a more extensive study of binocular summation in spatiotemporal vision is also consistent with this conclusion (Georgeson & Meese, 2007). Overall, the results here indicate that our observers were not binocularly compromised and so the lack of IOT at low spatial frequencies cannot be attributed to deficits in the binocular combination of the monocular contrast signals.

4 Discussion

We measured interocular transfer of the threshold elevation adaptation aftereffect for gratings at a range of spatial and temporal frequencies. We found that IOT increased with spatial frequency (and reduced as a function of stimulus speed), being essentially absent at the lowest frequency tested (0.5c/deg). The speed effect (Figure 4f) lends some support to our hypothesis that differences in IOT might be associated with magno and parvo pathways. However, given the lack of a significant temporal frequency effect (see Figure 4e and the first ANOVA reported in the Results section) we limit our discussion to low and high spatial frequency mechanisms. Overall, IOT was weaker than in previous studies, despite our observers being functionally binocular. We propose explanations for this discrepancy, and discuss our results in terms of binocular architectures for spatial vision.

4.1 Why did earlier studies produce such strong IOT?

The weak IOT reported here and in other recent studies (Cass et al., 2012; Falconbridge et al., 2010; Meese & Baker, 2011) conflicts with classical results from the literature (see Figure 1). We suggest two related methodological explanations for this discrepancy. The first concerns the

psychophysical methods used to measure thresholds. The majority of studies summarised in Figure 1 used the method of adjustment (indicated by circular symbols) – a criterion sensitive measure that is highly prone to observer bias. In fact, only four studies used a criterion-free forced-choice design (stars and triangles), with a further two using a yes/no task (diamonds; there is no indication that Snowden & Hammett (1996) corrected for bias, and although methodological details are sparse for the study by Timney, Symons, Wilcox, & O’Shea (1996), our reading is that an uncorrected yes/no task was used). It is conceivable that the use of bias-prone measures in most (12/16) studies might have increased the level of adaptation reported. For example, observers might set a higher criterion following adaptation, perhaps to compete against hallucinations visible from cortical disinhibition (Georgeson, 1976), which typically have different spatial properties from the adaptor. Even observer awareness of having been adapted could be sufficient to produce threshold elevation from expectancy effects. These ‘central’ effects would be expected to influence monocular and dichoptic thresholds equally. However, because IOT is calculated as the ratio of dichoptic to monocular threshold elevation (Björklund & Magnussen, 1981; Snowden & Hammett, 1996), increasing both by an additive amount (in dB) would artificially inflate the reported IOT values.

Secondly, particularly in older studies, the adaptation regime typically involved a static adaptor. Observers were instructed to move their eyes during the adaptation period to prevent the formation of local luminance afterimages. However, if observers failed to do so appropriately (in no study was this behaviour monitored objectively), high contrast adaptors could produce visible retinal afterimages with similar spatial properties to the target. These could act as a mask (or pedestal), perhaps spuriously increasing the apparent adaptation effects. Such masking effects could be stronger for dichoptic conditions, as threshold elevation from (real) grating masks is stronger when presented dichoptically (Legge, 1979; Meese, Georgeson, & Baker, 2006). Furthermore, visible retinal afterimages would likely amplify the problems of bias mentioned above.

Our study (and Meese & Baker, 2011) used a criterion-free performance measure (2AFC % correct), and our adaptors phase-reversed to prevent the formation of retinal afterimages.

We think that these superior methods provide a more reliable estimate of IOT. Nevertheless, we also note that stable estimates of IOT are difficult to obtain since they are derived from three independent measures of threshold—one at baseline, one following monocular adaptation and one following dichoptic adaptation—each having an associated measurement error. When threshold elevation effects are small, a slight mis-estimation of one of the three thresholds can produce a substantial shift in the reported IOT, perhaps even switching between positive and negative effects. We think that this accounts for the fairly high levels of variability in some of our data (Figure 4d-f), particularly from our non-expert participants. We also acknowledge that the levels of adaptation in the first and second intervals of our 2IFC design might have been different owing to the monotonic recovery from adaptation that follows the removal of the adaptor (Greenlee, Georgeson, Magnussen & Harris, 1991). Since target interval allocation was random, this would have averaged out over many trials, but it is likely that the overall level of adaptation was weaker than would be expected for single interval methods.

4.2 *Is target size important?*

Most of our strong IOT effects occurred for the 8c/deg target (though see also 2c/deg at 1Hz – red squares in Figure 4), and this contained more grating cycles than did the other spatial frequencies (see Methods). To test whether the number of cycles was important for IOT, we ran a control experiment using a larger (6.68 cycles FWHH) 2c/deg target at 4Hz. For observer DHB, this produced comparable levels of threshold elevation and IOT (11.5%) to the smaller version used in the main experiment (14.2% IOT), suggesting that large target size was not responsible for our IOT effects.

4.3 *Implications for binocular architectures*

Traditionally, incomplete interocular transfer of adaptation (i.e. <100%) has been interpreted as evidence that adaptation occurs at both monocular and binocular (serial) stages of processing (e.g. schematic in Figure 5a; see also Sloane & Blake, 1984). Adapting the right eye for the visual architecture in Figure 5a will produce desensitization (bold dashed lines) at both the monocular stage in the right channel and at the binocular stage. Both stages will affect thresholds for targets in the right eye, leading to strong adaptation effects. But for a target presented to the left (nonadapted) eye

the monocular stage has not been desensitized (thin dashed line). This means that any threshold elevation is due only to the binocular stage, and so should be weaker than in the monocular (right eye) case. This architecture therefore produces some level of interocular transfer, with the precise amount depending on the relative levels of desensitization at the monocular and binocular stages. This is the classical account of interocular transfer of adaptation effects (e.g. Sloane & Blake, 1984). Here, it is consistent with our results at high spatial frequencies and so we conclude that the classical architecture (Figure 5a) is a plausible description for such stimuli.

However, the classical account is not consistent with our findings at lower spatial frequencies where IOT was absent. We offer two possible explanations for this. One possibility is that adaptation occurs only at a monocular stage, and that binocular units do not adapt (at least not in a way that is relevant to threshold performance). With this arrangement (Figure 5b), adaptation aftereffects necessarily derive from the monocular stage, but since this is irrelevant for dichoptic adaptors there can be no IOT. An alternative account (e.g. Wolfe, 1986) proposes that monocular outputs are also available for decision-making (Figure 5c). With this arrangement, monocular adaptors raise detection thresholds in the adapted eye, regardless of whether the monocular or binocular output is used to perform the task. However, even though adaptation occurs at the binocular site, detection by the non-adapted (left) eye would be immune to this because of its own non-adapted monocular pathway. Therefore, dichoptic adaptors do not produce IOT. This proposal is also consistent with the finding that some observers can correctly report which eye has been shown a grating only at low spatial frequencies (utricular discrimination; see Blake & Cormack, 1979).

In summary, our results confirm that adaptation occurs at both monocular and binocular stages for high spatial frequencies. At low spatial frequencies adaptation is either purely monocular, or occurs at both stages but is effective only at the monocular stage owing to the existence of monocular outputs.

5 Conclusions

We have measured interocular transfer of threshold elevation after-effects from adaptation at a range of spatiotemporal frequencies, using criterion-free (2AFC)

(a) High SF

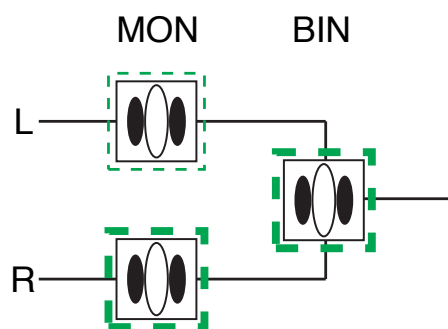

(b) Low SF (1 output)

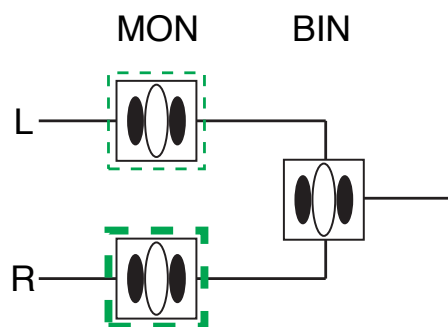

(c) Low SF (3 outputs)

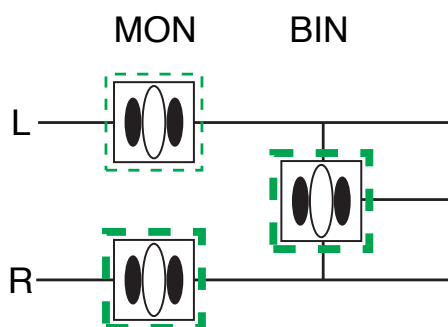

Figure 5: Possible binocular architectures for adaptation. (a) Classical explanation, in which adaptation occurs at both monocular and binocular stages. This is sufficient to explain our IOT data at high spatial frequencies (SF). (b,c) Alternative architectures with different properties to that in (a). Each is consistent with results at low spatial frequencies (see text for details). In all three diagrams, green dashed lines denote mechanisms that can be adapted, and bold dashes indicate mechanisms which are adapted by prolonged stimulation of the right eye only. L and R indicate left and right eyes.

psychophysical methods. We found that strong transfer effects occur only at high spatial frequencies, and that even these are weaker than previously thought. These results prompt a reassessment of early binocular architecture, and may indicate that monocular low spatial frequency mechanisms are available to perceptual decision making.

6 Acknowledgements

Supported by EPSRC Grant EP/H000038/1 awarded to Tim Meese and Mark Georgeson and BBSRC grant BB/H00159X/1+ awarded to Mark Georgeson and Tim Meese. We thank John Cass for providing a preview of his adaptation data.

7 References

- Anderson, P. A., & Movshon, J. A. (1989). Binocular combination of contrast signals. *Vision Res*, *29*: 1115-32.
- Baker, D. H., Meese, T. S., Mansouri, B., & Hess, R. F. (2007). Binocular summation of contrast remains intact in strabismic amblyopia. *Invest Ophthalmol Vis Sci*, *48*: 5332-5338.
- Björklund, R. A., & Magnussen, S. (1981). A study of interocular transfer of spatial adaptation. *Perception*, *10*: 511-8.
- Blake, R., & Cormack, R. H. (1979). On utrocular discrimination. *Perception & Psychophysics*, *26*: 53-68.
- Blake, R., Overton, R., & Lema-Stern, S. (1981). Interocular transfer of visual aftereffects. *J Exp Psychol Hum Percept Perform*, *7*: 367-81.
- Blakemore, C., & Campbell, F. W. (1969). On the existence of neurones in the human visual system selectively sensitive to the orientation and size of retinal images. *J Physiol*, *203*: 237-60.
- Campbell, F. W., & Green, D. G. (1965). Monocular Versus Binocular Visual Acuity. *Nature*, *208*: 191-192.
- Cass, J., Johnson, A. M., Bex, P. J., & Alais, D. (2012). Orientation-specificity of adaptation within and between the eyes. *PLoS One*, *forthcoming*.
- Falconbridge, M., Ware, A., & MacLeod, D. I. A. (2010). Imperceptibly rapid contrast modulations processed in cortex: Evidence from psychophysics. *J Vis*, *10*(8): art. 21. doi:10.1167/10.8.21
- Finney, D. J. (1971). *Probit Analysis*. Cambridge University Press.
- Fiorentini, A., Sireteanu, R., & Spinelli, D. (1976). Lines and gratings: different interocular after-effects. *Vision Res*, *16*: 1303-9.
- Georgeson, M. A. (1976). Psychophysical hallucinations of orientation and spatial frequency. *Perception*, *5*: 99-111.
- Georgeson, M. A., & Meese, T. S. (2007). Binocular combination at threshold: temporal filtering and summation of signals in separate ON and OFF channels. *Perception*, *36*(S): 60.
- Gilinsky, A. S., & Doherty, R. S. (1969). Interocular transfer of orientational effects. *Science*, *164*: 454-5.
- Graham, N. V. S. (1989). *Visual Pattern Analyzers*. Oxford University Press.
- Greenlee, M.W., Georgeson, M.A., Magnussen, S. & Harris, J.P. (1991). The time course of adaptation to spatial contrast. *Vision Res*, *31*: 223-236.
- Hanly, M. & MacKay, D.M. (1979). Polarity-sensitive perceptual adaptation to temporal sawtooth modulation of luminance. *Exp Brain Res*, *35*: 37-46.
- Hess, R. F. (1978). Interocular transfer in individuals with strabismic amblyopia; a cautionary note. *Perception*, *7*: 201-5.
- Legge, G. E. (1979). Spatial frequency masking in human vision: binocular interactions. *J Opt Soc Am*, *69*: 838-847.
- Legge, G. E. (1984). Binocular contrast summation-I. Detection and discrimination. *Vision Res*, *24*: 373-383.
- Lema, S. A., & Blake, R. (1977). Binocular summation in normal and stereoblind humans. *Vision Res*, *17*: 691-695.
- Levi, D. M., Harwerth, R. S., & Smith III, E. L. (1980). Binocular interactions in normal and anomalous binocular vision. *Doc Ophthalmol*, *49*: 303-24.
- Medina, J. M., & Mullen, K. T. (2009). Cross-orientation masking in human color vision. *J Vis*, *9*(3): art. 20.1-16. doi:10.1167/9.3.20
- Meese, T. S., & Baker, D. H. (2009). Cross-orientation masking is speed invariant between ocular pathways but speed dependent within them. *Journal of Vision*, *9*(5): 2, 1-15.
- Meese, T. S., & Baker, D. H. (2011). A reevaluation of achromatic spatio-temporal vision: nonoriented filters are monocular, the adapt, and can be used for decision making at high flicker speeds. *iPerception*, *2*: 159-182.
- Meese, T. S., Georgeson, M. A., & Baker, D. H. (2006). Binocular contrast vision at and above threshold. *J Vis*, *6*: 1224-1243.

- Meese, T. S., & Holmes, D. J. (2002). Adaptation and gain pool summation: alternative models and masking data. *Vision Res*, *42*: 1113-1125.
- Meese, T. S., & Holmes, D. J. (2007). Spatial and temporal dependencies of cross-orientation suppression in human vision. *Proc R Soc B*, *274*: 127-36.
- Merigan, W. H., Katz, L. M., & Maunsell, J. H. (1991). The effects of parvocellular lateral geniculate lesions on the acuity and contrast sensitivity of macaque monkeys. *J Neurosci*, *11*: 994-1001.
- Nishida, S., Ashida, H., & Sato, T. (1994). Complete interocular transfer of motion aftereffect with flickering test. *Vision Res*, *34*: 2707-16.
- Selby, S. A., & Woodhouse, J. M. (1981). The spatial frequency dependence of interocular transfer in amblyopes. *Vision Res*, *21*: 1401-8.
- Sloane, M., & Blake, R. (1984). Selective adaptation of monocular and binocular neurons in human vision. *J Exp Psychol Hum Percept Perform*, *10*: 406-12.
- Smith, R. A. (1971). Studies of temporal frequency adaptation in visual contrast sensitivity. *J Physiol*, *216*: 531-52.
- Snowden, R., & Hammett, S. (1996). Spatial frequency adaptation: threshold elevation and perceived contrast. *Vision Res*, *36*: 1797-1809.
- Timney, B., Symons, L. A., Wilcox, L. M., & O'Shea, R. P. (1996). The effect of dark and equiluminant occlusion on the interocular transfer of visual aftereffects. *Vision Res*, *36*: 707-15.
- Wade, N. J., Swanston, M. T., & de Weert, C. M. (1993). On interocular transfer of motion aftereffects. *Perception*, *22*: 1365-80.
- Webster, M.A. (2011). Adaptation and visual coding. *J Vis*, *11*(5): art 3.
- Wolfe, J. M. (1986). Stereopsis and binocular rivalry. *Psychol Rev*, *93*: 269-82.