

Some pages of this thesis may have been removed for copyright restrictions.

If you have discovered material in AURA which is unlawful e.g. breaches copyright, (either yours or that of a third party) or any other law, including but not limited to those relating to patent, trademark, confidentiality, data protection, obscenity, defamation, libel, then please read our [Takedown Policy](#) and [contact the service](#) immediately

THE DEVELOPMENT OF A TESTING PROCEDURE FOR
DRY FRICTION BRAKES

A thesis submitted to

THE UNIVERSITY OF ASTON

as part of the requirements

for the Degree of

DOCTOR OF PHILOSOPHY

BY

DONALD HATCH, B.Sc. Eng., M. Inst.P.

Faculty of Production Engineering

May, 1974

THESIS
629-11075
HAT

174 587 4 SEP 1974

LIST OF CONTENTS

	<u>Page</u>
ACKNOWLEDGEMENTS	
DECLARATION	
SUMMARY	
LIST OF FIGURES	
 <u>SECTION 1</u> 	
<u>Background and Design Considerations</u>	
<u>Chapter 1.</u> Introduction to Friction Materials for Braking.	1
1.1. Use of Friction Materials to stop moving vehicles.	1
1.2. Need for rapid assessment of Friction Materials.	1
1.3. Scope of tests needed to evaluate Friction Materials.	2
1.4. Testing Capacity required for Friction Material development.	3
1.4.1. Further demands on capacity made by the introduction of changes in production techniques.	4
1.4.2. Further demands made by changes of raw material supplies.	5
1.5. Summary.	5
 <u>Chapter 2.</u> Review of previous work on testing Friction Materials.	 6
2.1. Historical measurement of Friction.	6
2.2. Friction Materials in fields other than braking.	7
2.3. Testing friction materials for Automotive brakes.	11
2.3.1. N.P.L. Machine 1913.	11
2.3.2. Bockins and Hunt.	12
2.3.3. Sisman.	13
2.3.4. Taylor and Holt.	14
2.3.5. Kragelskii and Gudchenks	14
2.3.6. S.A.E. 1953	15
2.3.7. N. Carpenter.	16
2.3.8. Sinclair and Gulick	17

	<u>Page</u>
2.3.9. Meek	18
2.3.10. Finckh	18
2.3.11. Howard and Winge	19
2.4. Machines testing small samples	20
2.4.1. A. J. Wilson	21
2.4.2. General Motors 'Chase' machine.	23
2.5. The use of Road Vehicles.	24
2.6. Vehicle/Machine Hybrids. (Rolling Roads).	26
2.7. A full vehicle dynamometer.	26
<u>Chapter 3. Introduction to present work.</u>	
3.1. State of prior art of dynamometer testing.	28
3.2. Short comings of existing procedures.	28
3.2.1. Repeatability and reproducibility.	30
3.2.2. Correlation with vehicle results.	31
3.2.3. Speed of testing.	31
3.2.4. Transfer of development work to road vehicles.	32
3.3. Known sources of variation.	32
3.3.1. Wear.	32
3.3.2. Friction	33
3.3.3. Fade	34
3.4. Summary of variability.	35
<u>Chapter 4. Evidence in favour of complete vehicle simulation.</u>	
4.1. Complete simulation.	38
4.2. Specification of testing procedure.	38

SECTION II

Page

Design of Machine

<u>Chapter 5.</u>	Alternative control systems.	41
5.1.	Importance of temperature.	41
5.2.	Methods available.	41
5.2.1.	Control by magnetic tape.	42
5.2.2.	Computer control.	42
5.2.3.	Control by analogue.	43
<u>Chapter 6.</u>	Control method chosen.	44
6.1.	Analysis of brake application on a vehicle.	44
6.2.	Reproduction of the same cycle by XY plotters.	45
6.2.1.	Measurement of brake temperature by rubbing thermocouples.	45
6.2.2.	Copper control profile.	46
6.2.3.	Indexing of programmer by means of a uniselector.	46
6.3.	Programming of application and release speeds.	47
6.4.	Brake application pressure.	47
<u>Chapter 7.</u>	Design of test schedule.	48
7.1.	Choice of representative testing instead of overloading testing.	48
7.2.	Assessment of service conditions for brake linings.	48
7.2.1.	Selection of three typical temperatures of operation.	49
7.3.	Distribution of brake application & release speeds.	50
7.4.	Distribution of brake application pressures.	51
7.5.	Linearity of coefficient of friction with pressure.	51
7.6.	Establishment of three levels of braking duty.	52
7.7.	Number of brake applications per circuit.	52
7.8.	Compatibility of various control systems.	52
7.8.1.	Cooling rates and accelerated testing.	53
7.8.2.	Relationship between temperature and braking interval.	54

	<u>Page</u>
7.8.3. Achievement of the correct work rate/unit area, surface temperatures per unit work rate, and temperature gradients.	54
<u>Chapter 8.</u> Data Handling.	56
8.1. Recording all brake applications.	56
8.2. Redundancy of conventional performance tests.	56
8.3. Ultra short test charts as an aid to data handling.	57
8.4. Problems of handling charts of variable length.	57
8.5. Introduction of a recording XY plotter.	58
<u>Chapter 9.</u> Reliability of results, concept of cross checks.	60
9.1. Importance of cross checks.	60
9.2. Systems for cross checking.	60
9.2.1. Coefficient of friction.	61
9.2.2. For effective inertia of the machine.	62
9.2.3. For brake application speed errors.	62
9.2.4. Cooling rates.	63
9.2.5. Reproduction of temperature profile.	63
9.2.6. Measurement of temperature.	63
9.2.7. Brake rubbing in the release position.	64
9.3. Failure to find a suitable cross check for application pressure.	65
9.4. Torque measurement cross checks.	66
<u>Chapter 10.</u> Torque recording.	67
10.1. Use of a novel principle to reduce errors.	67
10.2. Discrimination between zero and sensitivity errors.	68
10.3. Facilities for retrospective correction of inaccurate results.	68
<u>Chapter 11.</u> Prototype performance.	69
11.1. Reason for performance check at prototype stage.	69

	<u>Page</u>
11.2.	Initial trials on a range of typical brake materials. 69
11.3.	Extended trials on a pair of similar brake materials. 69
11.4.	Precision of wear measurement. 70
11.5.	Repeatability over a time period. 71
11.6.	Standard deviation in friction and wear rate evaluation. 71

SECTION 4.

The fully developed machine

<u>Chapter 12.</u>	Completion of design to operate without technical supervision. 75
12.1.	Extension of flexibility. 75
12.2.	Multiplexing of XY plotters. 75
12.3.	Monitoring facilities. 76
12.4.	Torque measurement. 77
12.5.	Additional facilities. 77
12.5.1.	Integrated braking time. 77
12.5.2.	Total test time. 77
12.5.3.	Integrated testing time. 77
12.6.	Temperature monitoring. 78
12.7.	Additional fail safe systems. 78
12.7.1.	Over speeding of main motor. 78
12.7.2.	Location of chart or profile. 79
12.8.	Selection of application and release speeds. 79
12.9.	Manual overrides. 79
<u>Chapter 13.</u>	Selection of typical results. 81
13.1.	A complete test schedule. 81
13.2.	Changes in disc behaviour. 82
13.3.	Investigation of initial fade. 83
13.4.	Behaviour of drum brakes. 83
13.5.	Fade and recovery tests. 84

	<u>Page</u>
13.5.1. Conventional type of test.	84
13.5.2. New type of fade test.	85
13.5.3. Constant temperature profile testing.	86
<u>Chapter 14.</u> Some successful programmes carried out on the machine.	87
14.1. Variations in cast iron rotor behaviour.	87
14.2. Measurement of brake noise and squeal on the dynamometer.	88
14.3. Repeatability of friction material behaviour.	89
<u>Chapter 15.</u> Discussion.	93
15.1. Achievements.	93
15.1.1. Correlation with the vehicle.	93
15.1.2. Reproducibility of results.	95
15.1.3. Quality of results.	96
15.1.4. Cost and speed of testing.	97
15.1.5. Reliability.	97
15.2. Why results are better than expected.	97
15.3. Retrospective view of other dynamometer test facilities.	99
<u>Chapter 16.</u> Future work.	101
16.1. Practical.	101
16.2. Academic research.	101
16.3. Miscellaneous.	102
<u>Chapter 17.</u> Conclusions.	103
Appendices	
1. Three-factor analyses of variance on each of two material groups with replication.	106

Appendices
continued

Page

2.	Mixed duty schedule.	107
3.	Table of application and release speeds.	109
4.	Calculation of chart length/ μ relationship.	110
5.	Calculation of coefficient of friction scale for drum brake tests.	112

References.

Figures.

ACKNOWLEDGEMENTS

The Author is indebted to :

His supervisors Professor R. H. Thornley and Dr. R. C. Parker for their guidance and advice,

Mr. M. W. Moore, Manager of the Ferodo test laboratory for his help and co-operation throughout the project,

Messrs. A. D. M. Froot and D. Ediss for their expert contribution in the design and construction of the electronic components,

Mr. R. A. Harling for his competent handling of the statistical analyses,

The other members of the Ferodo Research Division for their help and co-operation during the investigation stages,

The board of directors of Ferodo Ltd. for their permission to submit the thesis,

Miss D. A. Naden and Mr. E. Hulse for the excellent job they made of typing the thesis and producing the drawings respectively,

And finally, to his wife and children for their patience and tolerance during the writing of the thesis.

DECLARATION

No part of the work described in this thesis has been submitted in support of an application for another degree or other qualification of this or any other Institution.

J. Hatch

SUMMARY

A description of the background to testing friction materials for automotive brakes explains the need for a rapid, inexpensive means of assessing their behaviour in a way which is both accurate and meaningful.

Various methods of controlling inertia dynamometers to simulate road vehicles are rejected in favour of programming by means of a commercially available XY plotter.

Investigation of brake service conditions is used to set up test schedules, and a dynamometer programming unit built to enable service conditions on vehicles to be simulated on a full scale dynamometer. A technique is developed by which accelerated testing can be achieved without operating under overload conditions, saving time and cost without sacrificing validity.

The development of programming by XY plotter is described, with a method of operating one XY plotter to programme the machine, monitor its own behaviour, and plot its own results in logical sequence.

Commissioning trials are described and the generation of reproducible results in frictional behaviour and material durability is discussed.

Techniques are developed to cross check the operation of the machine in retrospect, and retrospectively correct results in the event of malfunctions. Sensitivity errors in the measuring circuits are displayed between calibrations, whilst leaving the recorded results almost unaffected by error.

Typical results of brake lining tests are used to demonstrate the range of performance parameters which can be studied by use of the machine. Successful test investigations completed on the machine are reported, including comments on behaviour of cast iron drums and discs.

The machine shows that materials can repeat their complex friction/temperature/speed/pressure relationships at a reproducibility of the order of $\pm 0.003\mu$ and ± 0.0002 in. thickness loss during wear tests.

Discussion of practical and academic implications completes the report with recommendations for further work in both fields.

LIST OF FIGURES

<u>Chapter</u>	<u>Title</u>
2.3.1.	Fig. 1. General arrangement of first brake dynamometer (NPL).
2.3.9.	Fig. 2. Typical trace from 6 channel recorder.
3.1.	Fig. 3. Typical test schedule in current use.
3.2.2.	Fig. 4. Correlation of dynamometer and vehicle results.
6.1.	Fig. 5. Temperature/time curve for brake interface.
6.2.1.	Fig. 6. Double rubbing thermocouple assembly.
6.2.2.	Fig. 7. Prototype XY plotter controller.
7.2.	Fig. 8. Relationship between wear and mean journey temperature.
7.2.	Fig. 9. Diagram of simulated road circuit.
7.2.1.	Fig. 10. Distribution curve of mean circuit temperature.
7.2.1.	Fig. 11. Distribution of temperature for each duty level.
7.2.1.	Fig. 12. Temperature profiles for each duty level.
7.3.	Fig. 13. Distribution diagram of application and release speed.
7.7.	Fig. 14. Monitor of temperature through 200 applications.
7.8.1.	Fig. 15. Friction and wear results for normal and accelerated cooling.
8.3.	Fig. 16. Torque and pressure charts from tests described in 3.1.
8.3.	Fig. 17. Performance test plotted from data in Fig. 16.
8.3.	Fig. 18. Recorded μ and temperature profiles for a medium duty test.
8.4.	Fig. 19. μ /time and temperature/time curve for two levels of friction.
8.4.	Fig. 20. Two pressure charts showing different coefficients of friction.
8.5.	Fig. 21. Modified temperature/time profiles with constant temperature periods.
8.5.	Fig. 22. Single brake application as torque/time and torque/temperature.
8.5.	Fig. 23. XY plot with a few brake applications.
8.5.	Fig. 24. XY plot with a full compliment of applications.
9.2.1.	Fig. 25. Friction/time profile with cross check on average calculated value.

<u>Chapter</u>	<u>Title</u>
9.2.5.	Fig. 26. Malfunction of temperature monitor.
10.3.	Fig. 27. Measured μ/t curve with errors in sensitivity.
11.3.	Fig. 28. Alternate tests on two similar materials.
11.4.	Fig. 29. Graph of wear per circuit showing degree of scatter.
11.5.	Fig. 30. Moderately duty tests performed consecutively at intervals of one week, and on new samples.
11.6.	Fig. 31. Table of sources of variance.
12.2.	Fig. 32. The complete controller/result plotter.
12.3.	Fig. 33. Friction/temperature envelope with temperature monitor and parallel location lines.
12.6.	Fig. 34. Circuit diagram of re-transmitting slide wire.
12.8.	Fig. 35. Patch board circuit diagram.
12.9.	Fig. 36. The complete controller/result plotter, with dynamometer.
13.1.	Fig. 37. Typical light, medium and heavy duty circuits with temperature profits.
13.2.	Fig. 38. Effect of continual testing on a single disc.
13.3.	Fig. 39. Effect on performance of varying one constituent of the friction material.
13.4.	Fig. 40. Typical results obtained on a large commercial vehicle drum brake.
13.5.1.	Fig. 41. Conventional fade test presentation for a large commercial vehicle drum brake.
13.5.2.	Fig. 42. Fade and recovery test as in Fig. 41, but plotted by XY plotter.
13.5.3.	Fig. 43. Fade tests controlled by temperature profile.
13.5.3.	Fig. 44. Three fade tests at slightly different temperature conditions.
14.1.	Fig. 45. Variation in performance between cast iron discs to the same specification.
14.2.	Fig. 46. Noise measurement throughout a temperature programmed test.
14.3.	Fig. 47. Twelve individual brake applications from the 9th test circuit.
14.3.	Fig. 48. Corresponding twelve brake applications as in Fig. 47, from the 12th test circuit.
15.1.1.	Fig. 49. Front brake temperatures with mismatched discs.

<u>Chapter</u>	<u>Title</u>
15.1.1.	Fig. 50. Front brake temperatures with one disc replaced.
15.1.1.	Fig. 51. Front brake temperatures with both discs replaced.
15.1.1.	Fig. 52. μ /temperature graph for near side front disc.
15.1.1.	Fig. 53. μ /temperature graph for off side front disc.
15.1.1.	Fig. 54. μ /temperature graph for first replacement disc.
15.1.1.	Fig. 55. μ /temperature graph for second replacement disc.
15.1.2.	56 - 66. Batch 404 and 647 repeat tests on the same disc.
15.1.3.	67 - 73. Effect of small changes in composition of material.
15.1.3.	73 - 80. Effect of interaction between components of composition.

RESEARCH FOR MATERIALS FOR BRAKES

1.1. Introduction

The primary function of a vehicle is to transport people and goods from one place to another. This function is performed by the engine, which provides the power to move the vehicle. The engine is connected to the wheels by a drive shaft and a transmission. The wheels are in contact with the ground, and the friction between the wheels and the ground is what allows the vehicle to move. The friction between the wheels and the ground is also what allows the vehicle to stop. This is done by the application of a braking force to the wheels. The braking force is provided by the brake system, which consists of a brake pedal, a master cylinder, and brake lines. The master cylinder is connected to the brake lines, which are connected to the brake pads and shoes. The brake pads and shoes are in contact with the brake discs and drums, respectively. The friction between the brake pads and shoes and the brake discs and drums is what provides the braking force.

SECTION 1. -

BACKGROUND AND DESIGN CONSIDERATIONS

The design of a brake system is a complex task that involves many considerations. One of the most important considerations is the material used for the brake pads and shoes. The material must be able to withstand the high temperatures and pressures that are generated during braking. It must also be able to provide a consistent and reliable braking force. The material must also be able to resist wear and tear. The design of the brake system must also take into account the weight of the vehicle and the distribution of weight. The brake system must be able to provide enough braking force to stop the vehicle safely. The design of the brake system must also take into account the cost of the materials and the ease of maintenance. The brake system must be easy to use and easy to maintain. The design of the brake system must also take into account the safety of the vehicle. The brake system must be able to provide enough braking force to stop the vehicle safely in an emergency. The design of the brake system must also take into account the performance of the vehicle. The brake system must be able to provide enough braking force to stop the vehicle safely in an emergency. The design of the brake system must also take into account the cost of the materials and the ease of maintenance. The brake system must be easy to use and easy to maintain. The design of the brake system must also take into account the safety of the vehicle. The brake system must be able to provide enough braking force to stop the vehicle safely in an emergency. The design of the brake system must also take into account the performance of the vehicle. The brake system must be able to provide enough braking force to stop the vehicle safely in an emergency.

Method of Formulation

The method of formulation of the brake system is a complex task that involves many considerations. The method of formulation must take into account the material used for the brake pads and shoes. The method of formulation must also take into account the design of the brake system. The method of formulation must also take into account the weight of the vehicle and the distribution of weight. The method of formulation must also take into account the cost of the materials and the ease of maintenance. The method of formulation must also take into account the safety of the vehicle. The method of formulation must also take into account the performance of the vehicle. The method of formulation must also take into account the cost of the materials and the ease of maintenance. The method of formulation must also take into account the safety of the vehicle. The method of formulation must also take into account the performance of the vehicle.

CHAPTER 1. INTRODUCTION TO FRICTION MATERIALS FOR BRAKING

1.1. Use of Friction Materials to Stop Moving Vehicles

The most common method of controlling the speed of a vehicle is to convert excess kinetic energy into heat by means of a dry friction brake. Dry friction brakes take many forms, but in general fibre reinforced composite material is caused to rub against a rotating cast iron disc or drum and the heat generated is dissipated to atmosphere primarily by forced cooling of the metal member. In this country alone the amount of friction material produced per year exceeds £25m. in value and a very large amount of research work is devoted to improving the performance of these materials in many different respects.

As in many technologies the reason why development work is needed lies in the fact that many of the desirable properties constitute conflicting requirements, for example high coefficient of friction and good durability. Secondly the durability of current materials is such that the energy dissipated per unit mass worn away exceeds the heat of formation of the component ingredients by several orders of magnitude which in turn equals the amount of energy required to take the material apart atom by atom. Thirdly, they are expected to operate for many hundreds of hours at temperatures which, if the material were fully ventilated, would cause complete degradation of the material in a few seconds.

1.2. Need for rapid assessment of friction materials

Each of the changes made in the composition or method of formation of friction materials whether as part of a development programme, for production reasons, or due to a change in raw materials should ideally be

tested on a motor car for say 5,000 miles. This would yield one test result on one set of material and would cost £250. A duplicate test would therefore cost £500 and take six weeks using two vehicles simultaneously.

Clearly the cost of such a test is unacceptable except as a final check after a high degree of confidence has been achieved by cheaper forms of testing, but the time required is equally unacceptable.

The time required for a test must be minimised for three different reasons :- Material development programs must be completed in competition with other manufacturers, changes in production must be made acceptable before the material in production becomes obsolete, and raw material changes must be made acceptable before stocks of old materials are exhausted.

A target was set for the complete evaluation of a friction material in all its major properties in a period of 24 hours on a machine which could be duplicated at a reasonable cost of say £8,000.

1.3. Scope of Tests needed to Evaluate Friction Materials

One of the most important characteristics of a friction pair to be used in automotive braking is that the behaviour should be predictable so that the next time a driver applies his brakes he knows with fair precision what pedal effort he will need in order to achieve a desired deceleration. In order to satisfy this condition the only test variation which is tolerable is a slight and progressive decrease in coefficient of friction as the brake temperature exceeds say 200°C in the case of a drum brake, and 350°C in the case of a disc brake. The change must also be reversible as the temperature returns to a more normal value. Thus as the industry is at present constituted friction materials must be continuously developed which have stable behaviour over a range of rubbing speeds from 2 to 100 ft/s, pressures of 50 to 1000 p.s.i.,

the after effects of temperature varying from hundreds of hours at 200 - 300°C to periods of several minutes up to 800°C. They must be insensitive to changes within and between cast iron opposing members and last for say 30,000 vehicle miles when driven under 'normal' conditions. They must not be unduly sensitive to operating under wet or dusty conditions and must not exhibit to an unsatisfactory extent any of a list of 36 vices ranging from six distinguishable types of audible noise through various types of damage to the cast iron member such as scoring, thermal cracking, etc., to static interference with radio reception. All organic resin bonded materials are permanently affected by heat treatment at brake operating temperatures particularly in the presence of an oxidising atmosphere. The permanent thermal degradation diminishes with increasing depth into the brake lining, being a maximum at the operating surface of the material where the temperature is highest and oxygen is most readily available. Degradation increases with time but its effects are progressively removed as material is worn away. Thus, a varying state of degradation exists both at and below the surface depending on the relative magnitude of these effects, and it is one of the jobs of the material formulator to design compositions which are relatively insensitive to these variations, and the job of the test engineer to evaluate his success in this task.

It may be seen therefore that the test engineer must design test methods which not only cover a wide range of operating conditions, but do so after a wide range of previous history all of which are relevant to a wide range of service operating conditions.

1.4. Testing capacity required for friction material development

Current materials made for automotive brakes are generally comprised of mixtures of synthetic resins and rubbers, reinforced by asbestos fibre.

They contain metallic and mineral fillers, solid lubricants, controlled abrasives, and materials to suppress noise, inhibit corrosion etc. etc. It is not uncommon to find 10 - 15 different ingredients in one brake lining material.

When a new or improved material is required, several components will be varied singly or in groups in both quantity and type for each round of a formulation plan. Results of such a preliminary plan are then evaluated and further work of a similar nature planned, taking advantage of any improvement in performance which may have been achieved. Because many performance criteria have to be satisfied as outlined in 1.3. and the starting materials are already highly developed it is found that many tests have to be performed before significant progress is achieved. Unfortunately all performance characteristics interact, and therefore it is not possible to test for only one characteristic, say durability at light duty, as this would then be achieved at the expense of all the other characteristics. It is therefore necessary to test each material developed for all its required properties. At the present state of the art some 250 materials can be made and tested before one new commercially viable material is successfully developed.

1.4.1. Further demands on capacity made by the introduction of changes in production techniques

In the same way that each chemical ingredient of a material affects the performance of the final product, so do many of the operations of production affect performance. It is not sufficient merely to achieve a given set of physical properties in order to ensure a given performance, it is often the case that the route by which the end product is achieved is also important. This is clearly because the technology is not sufficiently understood, but never the less it still means that if production processes are changed performance of the end product must be checked.

Economic operation of the company demands that production tech-

niques must be changed as better methods become available, and as the manipulation of various production parameters is necessary to achieve some desired change without deleterious effects on performance, another large additional demand is made on testing capacity.

1.4.2. Further demands made by changes of raw material supplies

Because it is well recognised that additional loads on testing capacity are undesirable, only the most urgent changes in raw material supply are accepted for economic reasons. However the current political atmosphere makes it necessary from time to time to find new sources of many raw materials, as materials from old sources become unavailable or unreliable. Thus a third load is placed on the total testing capacity.

1.5. Summary

The friction material industry has been supplying brake linings for the automotive industry for seventy five years, and has up to date been able to keep pace with other developments. This has been achieved in the past by developing basic materials which will withstand more and more arduous operating conditions as the rate of dissipation of energy has increased with increasing vehicle performance.

At the present time however new materials are only being developed at prohibitive cost e.g., carbon fibre, inorganic polymers etc. and in addition to their cost, it is found in practice that their performance at the lower duty end of the scale is inadequate. Progress can now only be made by careful blending of existing materials which is both time consuming, and appears to be in a region of diminishing returns in terms of progress per new trial formulation. Hence the need for a rapid, reliable, and comprehensive method of testing at low cost.

CHAPTER 2. REVIEW OF PREVIOUS WORK ON TESTING FRICTION MATERIALS

2.1. Historical measurement of friction

Leonardo da Vinci (1492) stated that 'Friction produces double the effort if the weight be doubled'. That 'Friction made by the same weight will be of equal resistance at the beginning of its motion although the contacts may be of different breadths or lengths'.

He also stated that 'for surfaces smoothed and polished, friction is one quarter of the weight'.

Amonton rediscovered the same laws about 1699 and reported them to the Academic Royale des Sciences, who were sceptical, and in 1781 Coulomb enunciated the two laws of friction viz :-

1. Friction is proportional to load and independent of area.
2. Friction is independent of sliding velocity.

It was recognised later however that friction at high velocities was much lower than friction at more common velocities and in 1878 in his famous work on railway brakes Sir Douglas Galton showed that the friction both between cast iron brake blocks and wheels, also between wheels and rails decreased markedly with speed at high speeds.

By 1911 it was considered that Coulomb laws although sufficiently accurate for many practical purposes, were certainly incorrect under extreme conditions and had no pretensions to be looked at as really general laws.

2.2. Friction measurement in fields other than braking

Over the years there have been two basic approaches to the problem of measuring friction and wear - that of the engineer and that of the physicist. The engineer generally requires design and material data, whereas the physicist is interested in investigating the mechanisms of friction and wear. The engineer is interested in the friction of lubricated bearings rather than friction generally, and the classic work in this field was done by Beauchamp Towers in the 1870's. Towers ran the experimental bearing in a cradle, and in the later version of his apparatus added weights to a scale pan on a torque arm attached to the cradle to balance the frictional torque on the latter. The μ was of the order of 0.001. Because the friction in lubricated bearings is so low present day equipment has to be very sensitive and very accurate and the actual measurement itself must not disturb the system. The bearing is typically loaded by a four bar linkage, the test bearing being located at the mid-point of the upper horizontal beam, the load applied at the mid-point of the lower beam and a torque applied to keep the upper beam horizontal. It is vital to minimise the friction at the pivot points connecting the horizontal and vertical bars, and knife-edges are still often used. Resolutions of 0.1 lb.in. have been obtained for equipment capable of applying loads of 5000 lb. to the bearing, the corresponding torques being 20 - 30 lb.ft. This particular apparatus used externally pressurised bearings at the pivot points.

Most measurements on bearing test machines are tests of lubricants and are intended to rank the lubricants so that the more promising can be submitted to field tests. More recently there has been a trend to test the bearing materials themselves.

The engineers approach to the measurement of wear has not in general been very effective. Specimens have been run under severe conditions and the wear after a few minutes sliding or run was examined. In some of the older machines a ring or disc was run against a small flat specimen (Timken), two discs run together (Amsler, SAE,), a pin between two half collars (Falex)

or in a collar (Almen). Wear was determined by measuring the size of the scar, or materials were rated by measuring the time to failure (scuffing). Frictional torques could be obtained by measuring the force required to restrain the undriven disc. The early machines were inflexible in that the ranges of speeds and loads were limited, indeed some had but the one speed and the one load.

Another type of configuration is that of a pin sliding against a ring or disc. Contact may be between the pin and the edge of the disc or its surface. Instead of a single pin, two or three pins may be used. Two pins, one loaded against either side of the disc, ensures that the disc bearing carries no load and that the disc is not deflected. Wear is determined by measuring the thickness worn off the pins, or the diameter of the flats worn on them if the pins end in hemispheres or cones. This type of apparatus has been increasingly improved and instrumented. Wide ranges of speeds and loads can be used, rubbing temperatures and the frictions measured and recorded.

Another widely used equipment is the 4 ball machine in which a ball is rotated against a nest of three balls. Wear is determined from the scars formed on the balls and the frictional torque measured. The 4 ball machine has the advantage that the test specimens - balls of ball bearing races - are readily obtainable and very consistent in properties.

The value of wear data obtained even on present day equipment is often problematical. If a wear scar is formed during lubricated sliding, wear is measured at first under boundary or elastohydrodynamic lubrication conditions and then, if the scar becomes big enough, under full hydrodynamic conditions, whereas in service lubrication should be hydrodynamic in a properly designed system except possibly when stopping and starting. Surfaces may develop oxide and other protective films during sliding, for example, sliprings develop films of graphite and oxide, and in some systems the conditions under which these form is fairly critical and therefore cannot be simulated in

accelerated tests.

Many of the machines however can act as coarse filters to reject unsuitable materials and poor lubricants and they can sometimes rank materials and lubricants in much the same order as service measurements. They can also be used for quality control.

More significant data can be obtained using materials in the actual mechanism and submitting it to field tests. Radioactive and neutron activation techniques can sometimes make it possible to obtain data rapidly.

Physicists have obtained significant data with very simple equipment. Static friction is often measured by loading the specimen against a flat plate and applying a tangential load just sufficient to cause motion. Instead of using a tangential load an inclined plane has sometimes been used. The Bowden-Leben apparatus for measuring both static and dynamic friction has been the first of a number of similar machines. The hemispherically ended specimen is loaded against a flat surface driven, for example, by a hydraulic ram and is prevented from moving with the surface by an elastic suspension and the frictional resistance is determined by measuring the deflection of the suspension. Bowden and Leben used a bifilar suspension in their original apparatus. Elastic suspension can be troublesome as stick-slip motion occurs under some circumstances, though this can be avoided by using stiff suspensions and determining their deflection by strain gauges. Later apparatus of this type was modified so that measurements could be made at very high and very low temperatures, in vacuo, and in various atmospheres.

Instead of using the hemisphere on flat configuration crossed cylinders are sometimes used ; this arrangement has the advantage that by rotating the cylinders between measurements fresh surfaces can be used for each measurement. A further refinement is to rotate the transverse or rotate both surfaces during sliding, so that fresh contact areas are.

continually brought into contact.

Laboratory wear measurements are generally made using pin on ring or disc apparatus.

... friction ... A test report

... to a second ...
... and to ...
... to the torque

2.3. Testing friction materials for automotive brakes

2.3.1. NPL machine 1913

In 1913 a machine designed to test automotive and other friction linings was available at the National Physical Laboratory. A test report No. R60/13 covers extensive testing on a number of different materials supplied by the Herbert Frood Co. Ltd. The tests show that the friction materials of different types varied in behaviour as operating temperature, speeds and pressures were changed and that the variations of friction and wear were characteristic of the different materials.

The machine consisted of a fly wheel of just over 20in in diameter against the rim of which, the friction materials were pressed by a system of levers and a dead weight load. The wheel was driven at one of a number of constant speeds by a D.C. motor and the torque developed was measured by a second series of levers and bell cranks to a second dead weight loading pan. Oil damping was provided by a dash pot, and to measure the coefficient of friction, weights were added to the torque measuring pan until the bell crank floated between limits.

The size of the two samples employed was $5/8$ in x $2-1/2$ in and temperature was measured by an Iron Eureka thermocouple embedded just below the flywheel rim and fed out through two insulated copper discs dipping into separate troughs of mercury. At a temperature of 200°C the heat input and cooling losses equalised thus creating a natural limit to operating temperature. Within the range of operating conditions available the materials evaluated showed behaviour patterns which are still acceptable today as characteristic of the general groups of materials investigated, i.e. asbestos based, cotton based, die pressed and hydraulically compressed.

It was also noted that all materials were superior to naturally occurring materials such as 'red fibre', leather, and wood.

A general arrangement drawing of the machine is shown in Fig. 1.

2.3.2. Bockins and Hunt (1)

In 1935, Bockins and Hunt highlighted the increased traffic densities and vehicle speeds which coupled with the streamlining of bodies all combine to make the retarding of motor vehicles one of the 'Major Engineering Problems of Today'. They state that the 'tendency has been to eliminate any test equipment which does not employ a full size brake' and that 'manually operated machines are apparently being superseded by full automatic controls to eliminate the inaccuracies of manual operation'.

The machines described are conventional inertia dynamometers on which the proportion of a vehicle mass carried by one wheel M is represented by a flywheel plus shafting, motor, etc. such that the moment of inertia of the rotating assembly $I = Mr^2$. r being the radius of the vehicle wheel concerned. The flywheel etc. is accelerated by an electric motor and braked by a full sized brake according to a 'suitable' schedule. The operation of the dynamometer is not described in detail except insofar as the schedules 'parallel road tests'. It is stated that 'the present state of operation may be compared with the first attempts to use dynamometers to test Internal Combustion engines where it was necessary to develop the technique of test before the results were given much credence'.

Thus the inertia dynamometer capable of exactly simulating a vehicle brake application had replaced the continuous rubbing machine built by the N.P.L. and it was clearly recognised that a full size brake had considerable advantage over small sample machines.

The need to simulate a vehicle test schedule exactly was clearly recognised, but was not put into operation because short cuts were taken and considered to be admissible and stylised schedules grew into common use.

2.3.3. Sisman (2)

In 1936, Sisman reiterates the opinion that inertia dynamometers are clearly ideal for the examination of frictional qualities of braking surfaces and their effect on the mechanical characteristics of the design generally. However, he then says that the typical rate of wear achieved on an inertia dynamometer is only 0.1in in 84 hours of testing and he therefore reverts to a continuous rubbing machine operating at constant torque in order to evaluate resistance to wear. It was suggested that continuous rubbing should not exceed periods of say 1 hour and that these periods should be interspersed with cooling periods, the size of sample and mass of drum being adjusted so that at the end of a one hour rubbing period the temperature should not exceed say 450°F.

Thus although it was accepted that good simulation was necessary to obtain relevant frictional behaviour, wear could be investigated without imposing such limitations. It was not recognised that resistance to wear can be as dependent on operating conditions as can frictional behaviour, or alternatively resistance to wear was regarded as relatively unimportant.

Again although good simulation was recognised as important it is doubtful whether the philosophy was put into practise beyond making repetitive brake applications at what was thought to be a typical condition.

Coefficients of friction were calculated as usual by dividing the tangential force by the normal force, but also the concept of a 'performance test' was introduced. Still commonly used to day, this consists of a graph usually linear, relating average deceleration throughout a brake application to the brake pressure used for the application. The slope of such a line is thus related to the coefficient of friction of the materials under test.

Difficulties are described of the evaluation of the qualitative aspects of braking such as smoothness, freedom from smell and silence. It also points out that, as is the case today, 'squeaking troubles are as elusive in their incidence as in their cure'.

2.3.4. Taylor and Holt (3)

In order to avoid the self energising effects of a normal drum brake, and so facilitate the measurement of friction, Taylor and Holt used a full sized drum, but two 4 sq.inch. samples compared with some 30 square inches of lining which would normally be used. Temperature rise per brake application was therefore not matched to a full size brake, nor was the wear rate per application, or the wear rate per unit work done under specified conditions of running.

No external heating or cooling was provided, and the temperature was measured by the use of thermocouples rubbing on the operating surface of the drum. The machine would distinguish between textile linings and moulded linings and could discriminate between dry samples and samples which had been immersed in water for two hours. Although the coefficient of friction could be easily calculated, it is doubtful whether it had any real meaning, and in any case a knowledge of the self energising characteristics of the brake would still be required in order to convert the measured coefficient of friction back into a prediction of brake performance.

2.3.5. Kragelskii and Gudchenko (4)

Kragelskii and Gudchenko explain in great detail the necessity of retaining the geometric form of the friction surfaces in contact because 'these influence the formation and breaking up of films formed by the interaction of the surface layers with the surrounding medium'.

In addition they claim the necessity of reproducing the 'various states of heat formation and loss', and the need to conserve the state of

the 'ambient medium' (moisture, gas content etc.) which they say are equally important.

They go on to explain that under the influence of high temperature, of physical deformation, and of the surrounding medium, various complex physico - chemical processes give rise to new layers and films with the special properties which determine the value of the friction couple. Retaining the above parameters in their test machine ensures that 'the physico - chemical changes in the surface layers remain analogous'.

Having displayed such a clear insight into the importance of their various parameters it is extremely unfortunate that they went on to describe a small sample test machine employing cylindrical samples of 28 mm O.D. and 20 mm I.D. (rubbing on their ends). The provision of electrical heating and compressed air cooling was said to cause the thermal conditions to approximate 'in the highest degree' to those actually existing at the frictional junction. Thus, again a statement of what is needed was not followed up by a serious attempt to put the theory into practice.

2.3.6. 'Construction and operation of Brake Testing Dynamometers' (5)

This paper was intended to provide a basis for evaluating brakes reduced to common terms so that their performance characteristics could be more readily compared.

Temperature was described as a 'tool for analysis' and as such an important aid in the correlation of data between the field and the laboratory. It was recognised that strict comparisons could only be made if corresponding temperatures were equated. Under test control however, it was pointed out that comparisons of brake performance were almost meaningless unless procedures could be duplicated from one test to the next. The method of achieving this end was to maintain the interval between applications constant on the basis that shorter intervals would give rise to higher temperatures.

Thus although the importance of temperature is well recognised,

no importance is attached to the need to vary temperature as it would vary in service on a vehicle, and further, instead of controlling by means of temperature the choice was made to control indirectly by means of time intervals. Serious practical difficulties arise in this method of control either from uncontrolled variations in cooling rate, or the difficulty of actually controlling it to sufficient accuracy and time response.

2.3.7. Carpenter (6)

In 1957 Carpenter in an article entitled 'Testing Friction Materials' wrote that 'The testing of friction materials is greatly complicated by the obscure nature of the Friction phenomenon'. He goes on to stress that friction behaviour of a normal brake lining material is dependent on temperature, pressure, speed, contamination, humidity and previous history. 'Time effects can also enter into the measurements. In certain types of test machines, prolonged running at fixed speed, temperature and pressure is used. This can cause a conditioning of the surface of the material so that within the duration of a brake application the friction may change, owing to the build up of extremely thin films of resin on the drum surface'. Finally he points out that under the rapidly developing conditions of the day 'development work produces dozens of experimental linings in a single week'. In these circumstances it is clearly not practicable to test all materials on road vehicles and dynamometers must therefore be used as a filter to reject any material which does not show considerable promise before the successful few pass on for road testing. It was recognised also that 'a material that shows the best performance under overload or very severe conditions may not necessarily be the best in normal operation'.

In a paper of general interest he describes the use of small continuous rubbing machines for quality control and quality assurance tests but condemns them for use as absolute assessors of frictional behaviour. Inertia dynamometers of a general type are described together with

typical test schedules in use at the time. These comprised of groups of repetitive tests to measure durability and to 'condition' the material interspersed with 'fade tests' of varying severity. The characteristics of a material were then defined in terms of the cold friction level at various points through the test procedure, the variation of friction level throughout the first group of 30 brake applications under rising temperature conditions, and the n^{th} similar group after stability had been reached. In spite of his statement that good simulation of road service is necessary the tests used were still untypical of road usage and represented a driver intent on 'testing' his braking performance. They were therefore still over load tests, but by a lower magnitude than the tests which they replaced.

2.3.8. Sinclair and Gulick (7)

In a paper on a 'Dual Brake Inertia Dynamometers' a case is made for providing a dynamometer carrying two brakes, either 2 fronts or rears, or a combination of front and rear. The argument is based on the observation that on a vehicle, four brakes are coupled to the total vehicle mass effectively in parallel. Thus it is claimed that instability is set up of the type known as 'Torque transfer'. Two types are quoted, the first being due to materials whose coefficient of friction decrease with temperature. This is not a well known phenomena, but it is claimed that a time delay exists between the heating of the brake and its drop in friction due to the time required for heat soak and that this causes oscillation to occur in both temperature and torque. The second type of instability is much more well known and arises where brakes develop torque which rises with temperature. Clearly this type of brake is self destructive up to the point at which the brake changes and becomes temperature sensitive in the reverse direction since the brake which initially achieves a slightly higher temperature then does more work and so

accentuates the imbalance.

Results are quoted which show corresponding behaviour on the machine and a vehicle and a case is made to extending the principle further to a four brake dynamometer, which would simulate a vehicle even better.

Substantially the same work was reported in by Sinclair (8) with the addition of a mathematical analysis based on $a \frac{df}{dt} - bf = -T$ which as is pointed out by the Webber and Newcomb can have no general validity since f is put proportional to T in degrees Fahrenheit.

f = coefficient of friction of the brake

T = temperature in °F

t = time

2.3.9. Meek (9)

Describes an inertia dynamometer on which all four brakes of a car can be mounted simultaneously. The brakes are mounted in two pairs of front and rear assemblies, all on the same shaft line with the outer rotors driven by shafts coaxial with tubes on which the stationary parts are mounted. Programming was available up to 60 different consecutive brake applications based on a time cycle, and the output was recorded for each application of each brake individually on a six channel recorder together with a channel for machine speed and one for application pressure. Brake applications could also be made when the brake temperature fell to a constant pre-set value up to 1,000°F.

Fig. 2. shows a typical trace of the six channel recorder.

2.3.10. Finckh (10)

Makes the point that dynamometers can be used to simulate tests to destruction without risk of personal injury, and goes on to describe a conventional inertia dynamometer. He considers that the response time and deceleration build up times are important, but it is recognised that these are primarily dependent on the characteristics of the braking system.

Three possible modes of operation are available,

1. Manual braking to rest
2. Automatic braking to rest
3. Continuous braking.

In the automatic mode the machine is braked always to rest from a fixed speed and at a fixed pressure, but the cycle is initiated when the brake temperature falls to a pre-set value. Thus again, temperature control is available, but only to a fixed constant value.

2.3.11. Howard and Winge (11)

Describe what must be the most advanced design published to date. It consists of four conventional Inertia dynamometers layed out as 4 parallel shafts which can be run as 4 individual machines, two pairs, or a single 4 brake unit, by cross coupling pairs or all four shafts through bevel gears.

It is claimed that the machine gives extremely good test repeatability in contrast to vehicle tests on the public roads, which, according to the authors give virtually non-existent test to test repeatability due to variable ambient conditions and variable traffic. The authors point out therefore, that the concept that a road vehicle is the final arbitor of brake quality is unrealistic.

The machine is programmed by magnetic tape which can accommodate six hours of vehicle running. Initial and final speeds of each application are controlled, together with brake pressure or torque. The time interval between applications is controlled, and cooling air for each brake is independently variable and can be made proportional to dynamometer shaft speed.

It is interesting to note that the final comment by the Authors is that 'The application of unattended automatically programmed test results in rather a large quantity of recorded data which must be analysed'. They go on to say that 'It is relatively simple to

saturate the design engineers with test records'. A programme was therefore under consideration to interface the whole machine with on line digital computer to aid data reduction.

The cost of the whole installation is not quoted but must be between £150,000 and quarter of a million pounds. Later, the machine was quoted at ~~£~~1/2m. without computer or data processing.

2.4. Machines testing small samples

As the development of full size dynamometers has progressed from complete disregard for operating conditions (except that they should be reasonable) to more and more accurate simulation of what actually can be measured to occur on a road vehicle, so the development of small scale sample machines has followed a parallel path. It is always attractive to visualise small machines of which large numbers can be built at low cost, all producing masses of data at high speed. The fact that full scale dynamometers are no longer considered satisfactory unless they closely simulate vehicle operation, suggests that to add the problems of scale to the unavoidable difficulties of providing adequate simulation is quite the wrong way to go. Experience over many years has shown that the simple type of small scale machine frequently gives results which are sufficiently near the truth to be superficially acceptable, but sufficiently different from the truth to be thoroughly misleading.

Various machines are described in the literatures usually operating under conditions of continuous rubbing. These include the Chase machine (12), The F.A.S.T. machine (13) and a machine by Prof. H. Wright-Baker (14), in which three small samples were continuously rubbed against a water cooled bronze plate.

None of these machines could be expected to give data better than evidence of consistency, in spite of the fact that the Chase machine is still used as a measure of brake lining performance for legislative acceptance of friction materials for use in the U.S.A.

A machine employing small samples and operating under intermittent conditions was described by the Author and E. J. Goddard (15). This machine had the added advantage over previous machines in that the thermal capacity of the metal member (simulating drum or disc) had been scaled down in the same ratio as the lining sample area. Thus the rates of rise of temperature during an application and the thermal gradients within both pads and plate could be expected to simulate conditions of full scale. It was found however that although the machine was useful in a quality assurance capacity and could be used to investigate areas of academic interest, it fell far short of being adequate as a tool for forecasting behaviour on a vehicle. This was put down in part to the untypical availability of oxygen, which controls oxidative degradation of organic based friction materials at high temperature, due in turn to the untypical relationship between perimeter and surface area or sample volume.

It is of academic interest to speculate as to whether the effect of perimeter to area/volume ratio could be corrected for, by running in an atmosphere in which oxygen concentration is dilute, or even at reduced pressure. Certainly, this could be done for one material under one condition of running, but the 'cost/effectiveness' of such a development project does not seem attractive.

2.4.1. A. J. Wilson (16)

At the same meeting Dr. A. J. Wilson (16) described a small sample machine in which full note had been taken of the importance of correct scaling rather than merely using small samples, and of the importance of adequate programming. Three points are made which preclude the possibility of obtaining relevant friction/temperature characteristics of friction materials by the use of existing machines :-

1. 'The over large ratio of drum or disc rubbing area to specimen area results in temperatures totally unrepresentative of the work of the friction material specimen thus, masking its true friction/

temperature characteristics'.

2. 'Specimen loading was maintained constant. The drag load is therefore an uncontrolled variable and since it is the drag load which governs the energy dissipation, and thereby working temperatures, the use of constant specimens loading gives variable energy dissipation'.
3. 'Continuous rubbing at a constant slipping velocity was the only test condition available, experience has shown that intermittent applications are preferred to continuous rubbing, and that as most friction materials are velocity conscious, constant velocity testing was undesirable'.

A scale machine was built to a scale factor $S (= 10)$ in which the following relationships were maintained,

$$\text{Disc diameter} = 3.1\text{in} = D/\sqrt{S}$$

$$\text{Disc thickness} = 0.25\text{in} = T/2$$

$$\text{Friction pad area} = 0.5\text{sq.in.} = A/S$$

$$\text{Friction pad width} = 0.66\text{in} = W/\sqrt{S}$$

$$\text{Friction pad effective radius} = 1.2\text{in} = R/\sqrt{S}$$

The disc thickness was not scaled, but divided by 2 in order to represent single sided operation. It was therefore insulated thermally on the reverse side, the reverse face then taking the place of the centre plane of a disc operating normally.

Thus the following parameters can be maintained unscaled :-

1. Rubbing speed.
2. Energy dissipated per unit area of friction material.
3. Stopping time.
4. Deceleration at the effective radius.
5. Disc semi thickness.
6. Ratio of thermal capacity of disc to friction material areas.
7. Operating pressure.

Programming the machine was achieved by the use of a matrix board of 10 y axes (five initial speeds, three final speeds and two levels of deceleration) and 40 x axes yielding 40 cycles between repetitive parts of the sequence.

Evidence of good correlation with vehicle results is shown and as the authors state, the machine represents a very considerable advance over test rigs which were contemporary at the time of publication.

2.4.2. General Motors 'Chase' machine

The 'Chase' machine (12) is probably the best known small sample testing device, and has been adopted by the U.S. Federal Authorities as a standard machine for classifying friction materials, and thereby specifying the suitability of each material for different classes of vehicle. It consists of a full scale brake drum of 11in diameter which runs continuously, and carries a sample of friction material of 1 square inch area. It is supplied with heating or cooling from external sources. A modification of this machine was described by R. A. Muzechuk (17) in which the drum was replaced by a full size brake disc, and the 1 sq.inch sample was replaced by two 1/2 sq.in. samples.

After extensive testing on both the drum and disc variations of the machine it was concluded that :-

1. There was no relationship between the wear data of the two types of test, and the wear on the disc brake varied between 1/2 and 2 x the wear rate on the drum test.
2. The peak coefficient of friction was generally higher for the disc tests.
3. Fade was more pronounced for the disc test especially on the first run.
4. Considerable differences existed between the disc and drum data and in fact the two machines did not even put materials in the same rank order.

2.5. The use of road vehicles

The proper evaluation of friction materials for use on road vehicles can of course be done on the road vehicle itself. This method of evaluation has the advantage that only a knowledge of the operating conditions under which the performance is required is needed to ensure complete relevance of the results. This itself is however by no means simple and in addition there are a number of factors which tend to reduce the attraction of testing brake linings on a vehicle :-

1. Having decided on the operating conditions under which the vehicle should be run the choice must be made between operating the vehicle on a public road or on a special track. If the former is chosen it is very difficult indeed, due to varying weather and traffic conditions, to ensure good repeatability between tests. If the latter is chosen then the operation of the vehicle becomes a programmed sequence of brake applications performed by a driver who must then be a tester of brakes, whilst simultaneously being the driver of a vehicle, both tending towards full time tasks. In fact the function is usually performed by a team of drivers and observers who perform prescribed sequences of simulated service conditions. Thus the vehicle is braked to a schedule derived from service conditions, without the natural environment which generates typical public road usage. The result is that this type of testing falls short of precision which could be obtained on a dynamometer without the compensation of perfect relevance attributable to a true road test.
2. The total cost of testing on a vehicle is high, particularly where two man operation is required, and a contribution is made towards the upkeep and capital cost of a special track.
3. Vehicle testing is exceedingly time consuming. In addition to three shift operation the only method of accelerated testing available is

that of operating under overload conditions, which usually means unrepresentative high temperatures with the attendant lack of relevance, and the danger of causing entirely unrepresentative results.

4. It is difficult to resolve the performance of a total vehicle brake system into its component parts. Thus a vehicle equipped with disc brakes on the front circle and drum brakes on the rear cannot easily assess the behaviour of one without the interactions of the other. Even on a vehicle with disc or drum brakes on both axles, the two axles are never equivalent in their brake operating conditions and there remains a problem of interaction between the two different parts of the whole.

Vehicle tests are therefore best suited to the evaluation of the whole brake system, and very much less suited to the measurement of performance of the brake lining itself.

In an attempt to overcome the first of these problems the Author initiated work on the development of instrumentations which would monitor the duty level performed by the brakes of a road vehicle. A paper by Moore and Watton (18) describes the operation of the equipment which continuously evaluates the work done by the brakes so that at frequent intervals the wear sustained by the brakes can be measured and related to a 'duty factor'. In this way a wear rate/duty level curve can be constructed without the need for accurate repetition of operating conditions, and without losing the relevance of operation on the public road. An extension of this work to include the measurement of the relationship between frictional behaviour and duty level would constitute a step forward in the evaluation of vehicle brake linings and could well be undertaken as future development.

Cost and time however still constitute major difficulties in vehicle testing.

2.6. Vehicle/machine hybrids (Rolling Roads)

In an attempt to retain the advantages of testing a complete vehicle and at the same time operate under 'laboratory conditions' vehicles are sometimes run on rollers.

Generally the vehicle is mounted on four pairs of rollers, one pair for each wheel each pair being coupled through torque measuring devices to a bank of flywheels. Thus the vehicle as a whole can be operated, and the interactions between the brakes themselves and between the brakes and vehicle suspension can be maintained as standard. On the other hand the performance of individual brakes can be monitored by means of torque transducers and the whole device can be made independent of weather.

The operating cost is high including driver and rig operators, and the system suffers the lack of perfect relevance as mentioned under track testing. It is however very suitable for fault evaluation in brakes, but more particularly in brake systems as a whole.

2.7. A full vehicle dynamometer

The most advanced concept in brake testing has been put into operation by S.A.F.F. (Paris) in the form of a vehicle testing dynamometer. This device described by Odier (19) consists of a roller dynamometer involving a 2 metre diameter roller for each wheel. A vehicle supported on the rollers is constrained through its centre of gravity by a space frame capable of accepting or delivering thrusts fore and aft and sideways, and free to move in yaw, pitch and roll and also to move vertically and laterally. Thus the vehicle can be operated in any dynamic situation including continuous cornering, and the full performance of the brakes can be either monitored continuously from a control room, or from instrumentation in the vehicle under any of the above conditions.

It is difficult to imagine any behavioural characteristics of brake linings which could not be adequately simulated on this machine under

laboratory conditions. It's only disadvantage in the evaluation of brake lining behaviour is therefore operating cost, which includes driver, three control room operators and the amortization on about £3/4 million worth of equipment.

CHAPTER 3. INTRODUCTION TO PRESENT WORK

3.1. State of prior art of dynamometer type testing

The most commonly used equipment for testing automobile brake linings is a full scale inertia dynamometer fitted with a single proprietary brake. Test schedules have changed little since 1957 when Carpenter (6) described typical schedules in use at Ferodo Ltd. at that time. Such a schedule is laid out below, and Fig. 3 shows a typical set of results in the form in which they would be used by the development engineer. Most of the diagrams in Fig. 3 are self explanatory, but it is worth noting that none of the brake applications are shown as torque/time curves as in Fig. 2 but in the form of arrows indicating the salient points of the curve. Also only a small proportion of the total application made are recorded at all. The graph in 3a shows only the first of each of 13 groups of 30 applications at 'normal' duty to represent the change in cold friction level throughout the test. The graph in 3b shows a selection of applications from the first and 9th group consisting of the 1st, 2nd, 4th, 7th, 11th, 18th and 30th to show the change in friction behaviour within and between groups covering a temperature range of ambient and 160°C. Figs. 3c and 3d show fade and recovery tests representing moderate and heavy fade tests to 310°C and 400°C respectively together with recovery tests, and are described more fully in chapter 13.5. Wear measured gravimetrically and expressed as both weight and volume is measured after each group of 3 moderate duty groups and each fade test and is summarised in the graph E and the accompanying table.

3.2. Shortcomings of existing procedures

Over many years the above type of test procedure was used as a measuring tool in the development of friction material, and much argument grew up as to how reliable such tests were in terms of repeatability, and correlation with results obtained on the corresponding road vehicle.

On the one hand, test engineers claimed (rightly) that the dynamometers were under good control, that moments of inertia, braking speeds and pressures, and operating temperatures were accurate consistent, and therefore any variation between tests must be caused by failure to make test samples of consistent quality. The material technologists claimed on the other hand that samples were made under tight control and therefore any variation in results must be due to lack of repeatability of test procedure. Difficulty in resolving the problem was increased by a lack of understanding between test engineers and material technologists who were chemists.

It was fairly well established that two consecutive tests on the same type of material would frequently show very good correspondence, whilst repeat tests made over an interval of time were frequently widely divergent. It was also observed on many occasions that the two pads of friction material tested simultaneously on a disc brake test would show extremely similar wear rates, and although it was not possible to measure the coefficient of friction separately this evidence was taken as indicative that the two samples were probably similar in properties and that the differences between tests arose from lack of control of the test procedure rather than the material. However, no variability could be found in machine control which could account for variations over long time periods. Because academic research on friction phenomena shows that coefficient of friction is sensitive to minute amounts of atmospheric contamination it was even postulated that the time dependent part of test repeatability might be weather dependent and attempts were made to attribute it to humidity, pollution, and even sun spot activity.

Resolution of the problem was further handicapped by the nature of wear in that once a material has been subject to friction and wear, its chemical make up is permanently changed, maybe in depth, and therefore repeat tests on the same samples gave no guarantee that the material under

test could not be the entire cause of any variability in test results.

Against this background friction material development proceeded, dynamometer results being regarded with suspicion unless supported by other evidence such as fitting into an existing pattern of behaviour or even agreeing with the material technologists expectations.

3.2.1. Repeatability and reproducibility

It was not thought possible to separate sample to sample scatter from scatter caused by variability in testing procedure, but attempts to improve scatter by exercising care in the production of test samples was unrewarding. The conclusion was formed that it was probable that the major source of error lay in the testing procedure and the following experiment was performed in an attempt to quantify the conclusion.

Formulation changes were made to each of two starting materials, group 1 and group 2. Three ingredients A, B and C were added to each at three levels 1, 2, and 3, and samples of each resulting material (54 in all) were tested in duplicate using duplicate samples.

Friction tests were performed according to a standard schedule and the average values of coefficient of friction used to estimate the value by which coefficient of friction must differ between two single tests for the material to be considered different at the 95% level.

The results for the two groups, shown in appendix (1) were .034 and .023 respectively.

3.2.2. Correlation with vehicle results

Statistically it can easily be shown that a reasonable correlation existed between dynamometer test results and vehicle results. However as the curve in Fig. 4 shows the selection of an individual material from dynamometer results is a poor guide to the best material in performance on a vehicle. Again the problem exists that the particular samples of material used on the dynamometer cannot subsequently be used on a vehicle and vice versa without confounding variation within samples and variation between machine and vehicle.

Furthermore the value obtained for correlation coefficient between machine and vehicle depends on the particular range of materials chosen, and it can be expected that a range of materials which are relatively insensitive to operating conditions will give better correlation than those which are sensitive, thus correlation coefficient also depends on the materials chosen to measure it.

3.2.3. Speed of testing

In order to measure wear resistance of a friction material under reasonable operating conditions several days running are required so that repeatable measurements can be made of loss of thickness. Many attempts have been made to estimate durability in terms of weight loss, but these have been abortive due to variability in water absorption, and the difficulty in separating loss of moisture during test from loss of weight due to wear. Attempts to overcome this difficulty by drying the samples before and after test went some way to improving measurements, but the only way to achieve complete correction was to dry completely. It was then found that absolute dryness brought about changes in properties such that the action of drying itself resulted in loss of validity in the results so obtained.

Because the coefficient of friction of a material varies as the

wear process proceeds a measurement of either friction or wear is time consuming and may well take 72 hours of running time in order to cover a reasonable range of operating conditions. From the two preceding paragraphs it is clear that an isolated test is likely to give rise to an erroneous choice of material for further development. Even duplicate testing increases the time to test one material to 144 hours or over one week of 3 shift operations. This is clearly unacceptably slow.

3.2.4. Transfer of development work to road vehicles

Considering the various shortcomings of dynamometer tests and bearing in mind that in an attempt to develop a comprehensive test on dynamometers had led to the situation where machine tests no longer even had the advantage of speed, the decision was made to transfer the development of friction materials to road vehicles.

Once this decision had been made it was possible to concentrate effort on finding why dynamometer tests were inadequate and what must be done to improve their value.

3.3. Known sources of variation

In investigating the sources of variability, various measurements were made to determine the sensitivity of the parameters to be measured (wear, friction and fade), to factors which it was thought might be inadequately controlled, in order to identify sensitive areas.

3.3.1. Wear

1. It was found that at a nominal operating temperature of 200°C an increase in temperature of 20°C caused an increase in wear rate of no less than 40%.
2. Decreasing the clearance between pad and disc from 1/8in to zero during the 'brakes off' condition caused a 50% increase in wear rate.
3. The condition of the disc (i.e. previous wear debris removed or not) made no measurable difference.

4. The rate at which pressure was applied to the brake made no measurable difference.
5. The rate of release of pressure at the end of the brake application made no differences, provided the final release speed remained unchanged.
6. If the rate of release of pressure was reduced in such a way that the final release speed of the disc was lower, then wear increased.
7. The speed of the machine at the point where the brakes were applied made a great difference to wear rate. Operators were in the habit of setting the initial speed too high in the belief that the machine lost more speed between motor cut off and brake application than was actually the case. Indeed some operators were under the impression that full application pressure must be reached before the machine speed fell below the nominal application speed.
8. Errors in the initial speed setting from which the brake is applied from 740 r.p.m. to 780 r.p.m. gave rise to a 40% increase in wear.

3.3.2. Friction

It was found that neither small changes in temperature or initial application speed or 'off clearance' had any measurable effect on the measured coefficient of friction, but in estimating coefficient of friction from the slope of a performance test a difference between pairs had to be $.13\mu$ in order to be significantly different at the level of 95% confidence limits. This was attributed at the time to variations in the surface conditions of the material due to previous history of heat treatment etc.

In order to test the hypothesis that improvements in repeatability of friction and wear measurement could be obtained by departing from repetitive testing, a manually controlled sequence of applications was made according to

the schedule shown in Appendix 2 , temperatures ranging from 80°C to 400°C, application speed from 30 m.p.h. to 72 m.p.h. and equivalent decelerations from 30 - 70 % g.

The average coefficient of friction over each of six tests on six samples of the same material were 0.44, 0.43, 0.45, 0.44, 0.43 and 0.43 and the wear loss in inches of thickness were 0.0088, 0.0089, 0.0128, 0.0090, 0.0088, and 0.0089.

In the case of the 0.0128in wear loss it was found that the rubbing thermocouple used to control the temperature was malfunctioning and reading low.

3.3.3. Fade

Operating fade tests on the basis of fixed time cycle, inertia, initial braking speed, and measured flow of cooling air over the brake and disc, the final temperatures attained at the end of a sequence of 30 applications varied between 450°C and 600°C and the variation in brake fade was totally unacceptable.

It was concluded that since the energy input was fairly constant the cooling rates must have been badly controlled. Tests were therefore set up in which no cooling was employed and the cycle time increased to result in the same final temperature. At between 75 and 90 seconds cycle time with no cooling, similar wear and fade was observed as at 45 seconds with a 10 m.p.h. cooling draught. Three fade tests were then performed in duplicate with and without previous bedding at line pressures of 700, 800 and 900 p.s.i.

The results, tabulated below show that the temperatures achieved at the end of each test were much more consistent and that the wear per test were also reasonably consistent.

	Line Pressure	Mean Wear	Final Temperature
Without Bedding) 700	43.2 ins x 10 ⁻³	590°C
) 800	41.5 "	580°C
) 900	47.1 "	580°C

	Line Pressure	Mean Wear	Final Temperature
With Bedding) 700	36.5 ins x 10 ⁻³	590°C
) 800	39.7 "	590°C
) 900	45.5 "	595°C

It was also observed that the fade was reasonably consistent provided that bedded pads were used, and that the line pressure employed did not unduly affect results. It will be recognised of course that the line pressure does not affect the total energy dissipated during the test, but only the instantaneous rate of dissipation during each brake application.

3.4. Summary of variability

From the above experiments it is clear that :-

1. In order to yield repeatable results, great attention must be paid to detail, in particular those details of the schedule which give rise to variations in operating temperature viz :- Initial application and release speed, clearance during the 'off-period' of the brake cycle, and cooling conditions.
2. That a mixed duty type of schedule offers the possibility of better reproducibility of both friction and wear.
3. That apart from reproducibility, mixed duty schedules approach more nearly the conditions pertaining during a vehicle road test, and therefore stand a better chance of good correlation between vehicle and dynamometer.
4. It follows that vehicle tests performed to repetitive schedules, as for example on certain track tests, are likely to be subject to more scatter than would be the case on a controlled road test if such control were possible. However, where commercial considerations demands that such tests should be simulated on a dynamometer there is no alternative to simulating the repetitive schedule.

The decision was made that although it was not possible to prove conclusively that scatter in test results was wholly due to faults in test

procedures, rather than within and between sample variation, it would be good sense to go as far as possible towards improving test methods, and then re-consider the total scatter with a view to isolating the variability due to test samples.

CHAPTER 4. EVIDENCE IN FAVOUR OF COMPLETE VEHICLE SIMULATION

In the foregoing investigations there was considerable evidence that if an exact copy of a vehicle schedule could be programmed into a dynamometer then the dynamometer would give an identical result to the vehicle. Also if exactly the same test could be conducted, again on identical material, then the same result would again be obtained. Thus the problem to be solved in order to achieve correlation is to repeat a vehicle test exactly on a dynamometer, and the problem to be solved to achieve repeatability is merely to make such a test exactly repeatable in its important features.

It is not sufficient to measure the average condition under which a vehicle operates when in fact its operating conditions vary over a wide spectrum.

Similar conclusions are continually being reached in other fields of research, for example :-

Fatigue work

It is no longer considered adequate in the predictions of fatigue failure to apply repetitive strain cycles to a standard sample. Accurate prediction demands a representative programme of strain to be applied to a much more representative structure.

reference :- (20)

Behaviour of machine tool slides

Bell and Burdekin (21) found that the friction and wear behaviour of machine tool slides in service could not be adequately predicted by measurements made under cyclical test conditions, and that good predictability could only be obtained by careful simulation of service conditions to include non repetitive elements.

4.1. Complete Simulation

The decision was made to programme a dynamometer as nearly as possible representing a vehicle road test. It was recognised that an individual vehicle test would consist of a unique sequence of brake applications and would not be uniquely significant*. However in setting up a test representing an average vehicle schedule great care would have to be exercised to avoid falling into the same trap which the exercise is seeking to avoid. Thus one is trying to achieve the 'correct' degree of 'repeatable variability'.

It was considered that whatever programming system was chosen, it should be made extremely reliable, because the complexity of the schedule envisaged would be subjected to criticism if tests results were obtained which conflicted with the material technologists' expectation. Thus it was considered most important to be able to prove beyond doubt that if unexpected results occurred they could be firmly established as a real pattern of behaviour, and not to some uncontrolled variability in the performance of the dynamometer.

4.2. Specification of testing procedure

1. The test must measure the performance of full size samples of material functioning in their part as a component of a complete full size brake assembly.
2. It must be sufficiently comprehensive to cover all the major aspects of friction material performance (wear resistance, frictional behaviour, fade etc.) under a range of operating conditions varying in severity, in a target time of 24 hours.
3. It must be relevant in that it reproduces behaviour characteristics which would appear in similar tests on the road.

* Indeed an individual vehicle test might well contain untypical elements which would unduly accentuate some untypical piece of transient behaviour of the material.

4. It must be repeatable both in the short term and also between tests carried out over a period of years.
5. Above all it must be demonstrably reliable so that if test results emerge which are in conflict with the material technologists expectations it can be demonstrated in retrospect that exactly correct tests had been performed.
6. That 5, must be satisfied without producing an indigestible amount of data.

As the function of the machine is to measure the progress of friction material development, the precision of measurement required is much greater than for a machine whose function it is to evaluate the final product.

This is because in development it is necessary to evaluate numerous small steps of improvement which together add to a commercially acceptable improvement in performance. The commercially acceptable step in performance may well be an increase in average coefficient of friction from say 0.4 to 0.44.

The need is apparent therefore for a dynamometer which will characterise friction materials behaviour to a level of accuracy which is not currently obtainable, in which the most important feature is that even at enhanced resolution discrimination must be extremely reliable.

SECTION II

DESIGN OF MACHINE

CHAPTER 5. ALTERNATIVE CONTROL SYSTEMS

5.1. The importance of temperature

The temperature at which a brake is operated is well recognised as the most important parameter in determining the amount of wear which the friction material will experience.

Watton and Moore (18) showed under the author's supervision that the wear experienced by disc brake pads when operated on a road vehicle could be predicted for a given journey from a knowledge of the average brake temperature for the journey, independent of the type of driving employed, covering a range of drivers from professional test drivers to beginners.

From time to time however various authors have attached great importance to other parameters such as work done by the brakes, instantaneous energy dissipation rate or distance rubbed, nearly always because of their underlying influence on thermal stress, thermal shock, or chemical equilibrium. This has often led to the design of equipment in which temperature is inadequately adjusted by manual operation of the cooling fans, while great emphasis is placed on accurate control of the interval between applications, the machine speed between applications and rate of application of hydraulic pressure etc.

It was considered axiomatic that :-

1. The sequence of events occurring on the dynamometer brake application should simulate the vehicle most closely in those parameters found to be most crucial.
2. The least critical parameter should be left to accommodate uncontrolled environmental changes.

5.2. Methods available

Having decided to programme the machine by means of the brake temperature and that the temperature should be continuously varied, three

methods presented themselves, each of which offered means by which the braking speeds and pressures could also be varied from application to application.

5.2.1. Control by magnetic tape

Superficially the most attractive method was to make the dynamometer capable of taking instructions from magnetic tape on which the braking parameters of a journey on a vehicle had been recorded. Two problems arise however, firstly if the type of each brake application is recorded on tape, i.e. initial and final vehicle speed, brake pressure, and time or distance interval between brake application, and these are to be reproduced on the dynamometer, then programmable cooling for the brake would be required so that each application could be made at both the correct time and at the correct temperature. Alternatively one could correct temperature after each brake application by varying the cooling rate dependent on whether the brake was tending to run over hot or cool, but this would pose the problem of trying to match a rapidly varying control value by means of adjustments to a system of inherently long time constant. Both these problems seemed to present great fundamental control difficulties.

Secondly if controlled by tape, the dynamometer would have to match the vehicle in duration of test, and no economy in test duration would be possible, by means of, for example accelerated cooling.

Thus it was considered that control by tape not only presented severe difficulties but also imposed considerable limitations.

5.2.2. Computer control

An on line computer was next considered, but clearly the use of a computer for one machine would be extravagant, and the task of programming an economic number of machines by computer before establishing that the system would be satisfactory in principle was considered unadvisable. Also the problem of programmable temperature by continually varying cooling would still exist, and again no economy could be expected in terms of test

duration.

5.2.3. Control by analogue

The most serious difficulty in the above systems seemed to be that of achieving good control of temperature whilst specifying brake application type and interval.

It was considered that the best solution to the problem would be to initiate brake applications when the brake reached a predetermined temperature, and to allow the interval between brake applications to vary slightly as small changes in environmental conditions occurred. Under these conditions as an additional bonus it was envisaged that it might ultimately be possible to achieve economy in testing duration by employing accelerated cooling.

It was considered that a pattern of brake application temperature could be chosen from the behaviour of a vehicle under service conditions, and that an XY plotter would form the basis of an instrument which would respond to the pattern and could then be used to control a standard inertia type dynamometer.

A post office uniselector could then be employed to select various application speeds, release speeds, and pressures in sequence to form a completely flexible programming unit. No conflict would then occur between time, temperature and cooling rate and it would not be necessary to vary cooling rate within a given test. Cooling rate could however be varied between tests in order to establish whether accelerated cooling could be employed without deleterious effects, and if this were found to be the case considerable economy of time could be achieved by the inexpensive means of providing sufficient cooling air.

Accordingly work was initiated in this direction.

CHAPTER 6. CONTROL METHOD CHOSEN.

6.1. Analysis of brake application on a vehicle

Consider the sequence of events during one single application of the brakes on a vehicle equipped with disc brakes. If the surface temperature on the rubbing path of the disc is measured by a rubbing thermocouple of such a thermal capacity that it will respond to the rise in temperature during one application of the brakes then the temperature/time curve will be as shown in Fig. 5. The curve A.B. represents the approximately adiabatic conversion of kinetic energy into heat while the brakes are applied. For brake applications down to low speed the curve may reduce to zero or negative slope towards the end of the application due to the reduced rate of heat input, but for higher speed check brake applications the curve will be substantially as shown, Newcomb (22). B.D. represents the cooling between applications which is terminated at the point C where the next brake application is made.

The heat input causing the temperature rise A.B. is well defined in terms of the mass, speed, deceleration, and braking rates of the vehicle, but the maximum temperature B is difficult to measure due to its rapid rate of change, its associated steep temperature gradient normal to the disc surface, and the rate of diffusion of heat from the surface to the bulk of the disc. It is also difficult to define under conditions where hot spots are formed round the rubbing path, or where braking occurs in strips across the braking path. It is however well established that for normal brake applications some 95% of the total heat generated passes into the disc, and that for normal brake applications the heat generation is nearly adiabatic. During cooling however the temperature becomes much less ambiguous as cooling proceeds, due to the collapse of high temperature gradients during the period of heat soak. Hence the least ambiguity of temperature occurs at the last instant before the brake is again applied.

It was considered that the accuracy with which vehicle brake temperature could be simulated in a dynamometer programme was of prime importance and thus brake application temperature was chosen as the programming parameter. It was considered that accurate representation of the energy to be dissipated in each brake application should be aimed for and therefore accurate application and release speeds should be used, together with the correct proportion of vehicle inertia to be represented by the flywheels. Braking interval however was not considered to be important provided that it was fairly representative, and therefore it was feasible to leave braking interval to vary as necessary in order to accommodate the slight variations which always occur in cooling coefficient, heat balance between disc and atmosphere during brake applications, effects of maldistribution of heat input over the rubbing surfaces, heat loss in products of wear, and other uncontrollable factors in the thermal conditions. The rise in temperature between brake application and thus a knowledge of the points A.C. could be used to define the temperature conditions to be matched on a dynamometer from any given vehicle schedule.

6.2. Reproduction of the same cycle by XY plotters

6.2.1. Measurement of brake temperature by rubbing thermocouples

Because of the importance of temperature as the main control parameter it was decided to duplicate the rubbing thermocouples as shown in Fig. 6. Each thermocouple was welded to the back of a cast iron rubbing button which was supported by a pair of spring wires as shown. The centre block holding the springs was free to rotate so as to ensure equal rubbing pressure on each button, and one thermocouple was used to provide the control signal whilst the other was used to check on its satisfactory operation. Insulating material was moulded to the back surface of the cast iron button reducing the effect of heat losses from the thermocouple wire on the thermo electric junction, this being advisable due to the need to operate the system in the presence of high velocity cooling air provided to cool

the brake disc. This provided the temperature signal which was fed to the Y amplifiers of a Bryans Model 21001 XY plotter.

6.2.2. Copper control profile

A profile was etched from copper on printed circuit board such that its shape represented a sequence of successive brake application temperature plotted along the Y axis, spaced out at equal intervals along the X axis. The length of the profile along the X direction was made to fit conveniently on the table of an XY plotter and the temperature scale chosen to occupy the lower half of the table in the Y direction. An electrical contact was attached to the carriage of the XY plotter as shown in Fig. 7. The location of the contact was such that if the temperature signal applied to the Y input left the contact touching the copper profile, an electrical circuit was completed which energised a solenoid. The solenoid actuated the main accelerating motor of the dynamometer starting the sequence of events resulting in a brake application. If the temperature rise in the brake disc was sufficient to move the contact away from the profile thus breaking the motor actuating solenoid circuit then the brake would cool until such time as the temperatures fall reestablished contact, after which the next brake application sequence would be initiated. Failure to clear the profile would of course cause repeated applications until such a condition was achieved.

6.2.3. Indexing of programmer by means of uniselector

When the brake application temperature was reached the actuation of the accelerating motor solenoid also provided a signal which 'notched on' a uniselector of the type used in telephone switch boards. The uniselector performed two functions, its contact banks being used to select the initial and release speed for each brake application and also its brake pressure, and the stepping motor was used in conjunction with a small pulley and wire to move the XY plotter carriage the appropriate distance along its X axis.

Thus only the Y amplifiers were used on the original control unit, the X amplifiers being removed and used as spare units (this situation was changed later).

6.3. Programming of application and release speeds

The selection of application and release speed for each brake application was achieved by employing two banks of contacts on the uni-selector to provide voltages which could be matched against the output from the dynamometer tachometer generator and used to initiate or terminate the brake application. Some small problem exists in applications to rest since at rest the generate voltage is zero, and a small finite voltage completed the brake release at zero speed.

6.4. Brake application pressure

This was selected by a third bank of contacts which selected one of a series of electro pneumatic valves each backed by pre-set air pressures operating the brake through a single air/hydro pump. Thus it was quite feasible to employ a different application and release speed for every application of the brake and to employ a large number of different pressures. In fact however, brake usage work discussed later suggested that this was unnecessary, and in general only two pressures were used one of 200 p.s.i. representing the majority of application and one of 300 p.s.i. as explained in chapter 7.4.

CHAPTER 7. DESIGN OF TEST SCHEDULE

7.1. Choice of representative testing instead of overload testing

Overload testing is frequently resorted to on dynamometers in order to increase the rate at which material is worn away thus facilitating accurate wear evaluation. If this is done by making brake applications from higher equivalent speeds, then each application of the brake is made under non-representative conditions, and therefore although wear rates may be increased in a systematic manner there is no reason to suppose that the friction characteristics will be representative. If higher brake pressures are employed then although the rate of dissipation of energy is increased within an individual application the total work done per application is unchanged and therefore there is no significant increase in wear rate over the range normally used for a given number of applications of the brake. The use of a flywheel with a higher moment of inertia than that representative of the vehicle would result in a higher rise of temperature per application and therefore again would be expected to yield unrepresentative friction results. It was decided therefore that each application of the brakes on the dynamometer should be representative of the vehicle in speed, pressure, and energy dissipated, and thus minimise the risk of losing relevance from either known or unknown sources.

7.2. Assessment of service conditions for brake linings

Work done under the Author's supervision by Moore and Watton was relied on heavily for the data on which brake test schedules were designed. Reported under the title of 'Disc Brake Pad Wear Evaluation' Proc. Auto Divn. Inst. Mech. E. 1970 - 71 P.127 this work showed that provided the overall distribution of temperature of the vehicle brakes was not excessively abnormal for a given journey, the lining wear for that journey could be related to the average brake temperature, and the effects of occasional random untypical elements could be ignored. Fig. 8. shows a

graph relating wear per 100 miles against mean journey temperature in °C.

However, the inclusion of untypical elements could well have a lasting influence on the subsequent friction behaviour and the need was seen therefore for an entirely typical temperature pattern representative of the various duty levels to be simulated.

The work reported by Moore and Watton (ref.18) had led to the compilation of a large amount of data on brake usage on a particular road circuit shown in Fig. 9 and this was used to establish the temperature levels to be simulated, the temperature distribution within a circuit and the relevant values of the various other parameters.

7.2.1. Selection of three typical temperatures of operation

A total of 131 journeys around the above road circuit were driven by 8 different drivers varying their driving techniques from leisurely to as fast as possible, under all weather conditions. During each journey the temperature of the front discs was measured every half second during each brake application and recorded. A mean temperature/frequency diagram was then constructed from the average temperature for each journey (averaged during the brake application time) and the resulting diagram is shown in Fig. 10. The minimum and maximum values of mean temperature were 70°C and 260°C respectively.

In order to evaluate the behaviour of friction materials under conditions representing different conditions of driving the diagram was divided into three arbitrary sections whose mean operating temperatures were 100°C, 150°C, and 210°C and these were called light, moderate and heavy duty conditions respectively.

For each of the three duty levels, several individual circuits were selected as typical and these were averaged and smoothed to produce a typical temperature ranges & means for each level of duty Fig. 11. It was found that as the duty level increased from light to heavy, the average temperature increased without changing the basic shape of the temperature/time profiles.

Accordingly the three profiles shown in Fig. 12 were deemed to be typical.

7.3. Distribution of brake application and release speeds

Histograms showing the distribution of brake application and release speeds for circuits of the selected average temperatures is shown in Fig. 13. It is clearly shown that journeys made at a high average temperature contain a higher number of applications in total despite the fact that at higher average speeds the total journey time is reduced. Thus the higher temperatures are achieved by a combination of higher braking speeds both at applications and release and increased frequency of application. Because it was intended to employ temperature control instead of controlling cycle time, an increase in frequency of brake applications becomes automatic as the brake operates at higher temperatures, because of the increase in cooling rate. It was only necessary therefore to increase the speed level, both application and release, between duties. Although it was quite practical to employ a large number of different applications and release speeds, the unselector being capable of making all applications different, it was thought unnecessary to employ more than four applications and four release speeds. In this way by carefully selecting speeds typical of the relevant distribution curves in Fig. 13 and combining each application speed and each release speeds a total of 16 different energies could be dissipated. In practice however the lowest application speed was invariably lower than the highest release speed and thus only fifteen combinations were usable. Further justification for minimising the number of application speeds arises from the desire to retain the capability of comparing similar applications in which say, a given application speed may be compared over a range of temperatures or alternatively a given temperature and speed of application with the passage of time.

In the compilation of application and release speed sequences it was found necessary to bias the higher speed application so that their occurrence coincides to a limited extent with the rapidly rising temperature parts of

the circuit. However, far from this being considered as a disadvantage it was recognised as an indication that the control system was simulating well, because it seemed natural to find that a concentration of higher speed applications would in fact give rise to both high temperature and high rates of rise of temperature.

7.4. Distribution of brake application pressure

Observation of the drivers effort applied to the brake pedal showed that a hydraulic line pressure of about 200 p.s.i. was normal and that this value was only substantially exceeded during emergency stop conditions or very occasionally when the drivers estimation of speed or distance was in error. It was decided therefore that the majority of brake application on the dynamometer should be made at 200 p.s.i. line pressure with occasional applications at 300 p.s.i. The higher pressure applications were included to break up the strictly repetitive nature of the load pattern, and it was decided that nine or ten higher pressure applications would, in combination with the continuously varying temperature, be sufficient to loose all effects of repetitive conditions. It was recognised also that if justification could be found for maintaining the majority of applications at constant pressure then the resulting torque curves could be calibrated directly in coefficient of friction and that this would greatly ease data handling problems.

7.5. Linearity of coefficient of friction with pressure

Experience has shown that when friction materials behave anomalously, that is when they exhibit abnormal behaviour, they are frequently sensitive to pressure. Thus a continuous test showing that the torque/pressure curve is linear and proportional is a good guide to checking abnormalities. It was recognised therefore that to record torque at constant pressure with occasional applications at 50% higher pressure constituted a good guide to anomalous behaviour, and care was taken in the presentation of results that the easy comparison of torque at two fixed pressures was retained for this

purpose.

7.6. Establishment of three levels of braking duty

To a first order of approximation brake application pressure was found to be independent of average journey temperature and speed, and therefore three test schedules were set up representing light, medium and heavy duty. The temperature distribution were as in Fig. 12, the application and release speeds were as shown (see appendix 3), and the brake application pressures were all at 200 p.s.i. except for 9 applications distributed through the test schedule which were all at 300 p.s.i.

7.7. Number of brake applications per circuit

The results of vehicle tests showed that on a moderate duty circuit about 200 brake applications were made. It was considered that the wear which took place under these conditions could be measured with sufficient accuracy and that at heavy duty more wear would obviously take place. Although at light duty the evaluation of wear resistance would be marginal it was decided that the importance of wear under these conditions was not sufficiently great to warrant extending the test, and thus for simplicity of control 200 applications per test was accepted as standard.

Fig. 14 shows a complete temperature profile of a moderate duty circuit of two hundred brake applications with an inset showing two complete cycles and the stepping motor indexing along are 200th of the X axis from C to D.

7.8. Compatibility of various control systems

On a vehicle the rate at which the brakes cool is determined by the excess of the brake temperature over ambient and the air flow over the brakes. The air flow is in turn dependent on the vehicle speed, atmospheric conditions, the aerodynamic properties of the vehicle shape, and the design of the brake and wheel assemblies. Precise simulation of such complicated factors would be time consuming and expensive but exact reproduction of such factors is unnecessary in view of the diminished role of cooling, resulting

from the selection of control by application temperature. Since the control technique ensures that brake applications are initiated at the correct temperature, the rate of cooling is only required to provide a time interval between successive applications of the brake, and to ensure that representation of the vehicle is satisfactory and that unrealistic temperature gradients are avoided.

Also it may be seen that the interval between applications varies from application to application in such a way as to represent truly the same sequence on a vehicle. Thus on a vehicle, the temperature of an application is determined by the temperature of the previous application and the interval between them, while the dynamometer achieves the exact replica by making the interval between applications dependent on the temperatures of the two consecutive applications.

Thus exact simulation is achieved without the incompatibility of various control requirements.

7.8.1. Cooling rates and accelerated testing

Referring back to Fig. 5 it is known that during the brake application period AB the temperature rise is almost adiabatic and the ratio of times during AB and BC is typically 1 : 9. Under these conditions the cooling air supplied has little effect on AB but can have a large effect on the duration of BC. Thus the use of excessive air cooling can reduce the total time required to perform 200 brake applications without seriously affecting the thermal conditions during the brake applications. Although it can be argued that increasing the rate at which applications are made will reduce the time during which chemical changes can occur at and below the rubbing surfaces between applications, these effects might be small if the thermal conditions during applications remained representative of the vehicle. In order that this assumption could be verified two consecutive circuits were performed using a brake material which was especially sensitive to temperature variation under two rates of cooling, such that the total time

for a circuit of 200 applications varied from normal to one third normal. The results Fig. 15 showed that the total wear rate was unaffected, and the friction/temperature characteristics were similar. In fact the total variation of friction with temperature was slightly reduced at the higher rate of cooling, and this result was compatible with the idea that the changes were somewhat time dependent. It was concluded however that the advantages of accelerating the tests by a factor of three outweighed the disadvantage of a slight reduction in the measured sensitivity to temperature, and provided that this effect was borne in mind when assessing results the concept of accelerated testing was acceptable. It was also argued that since cooling rates vary considerably from vehicle to vehicle the machine results would at worst be representatives of a vehicle with a good cooling coefficient. Accordingly it was decided to use a volume of cooling air such that an acceleration factor of three was achieved.

7.8.2. Relationship between temperature and braking interval

Since a constant rate of cooling air was to be used throughout the tests it may be seen that when the brake is being operated at high temperature, the interval between brake application is reduced for a given change in application temperature. This is compatible with the behaviour of a vehicle brake as it has already been shown that at high temperature running more applications are made per unit time. Thus the method of control chosen can be seen to be an improvement over the conventional control system of constant interval between applications.

7.8.3. Achievement of the correct work rate/unit area, surface temperatures per unit work rate, and temperature gradients

The choice of a full sized brake ensures that within a given brake application of typical speed, inertia, and brake pressure all the thermal conditions of brake pads and disc are typical of a road vehicle. The fact that no external heating need be applied, ensures that the temperature at which the brake operates at any time is dependent only on the recent history

of brake useage, and therefore typical of rate of working at which the brake is being operated. This is of course not the case in small sample machines where external heat is used to raise the temperature of a massive disc and high temperature can be achieved at low work rate. Temperature gradients in both pad and disc, both normal and parallel to the rubbing surface are of course identical to those occurring on the vehicle since each individual application of the brake is an exact replica of a vehicle application.

CHAPTER 8. DATA HANDLING

8.1. Recording all brake applications

In conventional dynamometer testing as described in 3.1. it may be seen that sequences of repetitive brake applications are made, interspersed by performance tests which measure the frictional characteristics of the brake material at fixed points throughout the tests. Because repetitive testing is used, there is little point in recording all applications of the brake, since this would result in a series of friction/time curves in which the friction of the brake tends asymptotically towards an (untypical) equilibrium. It is sometimes thought worth recording applications in approximately geometric progression - say the first five, every tenth up to 50 and every 50th up to say 200. However this behaviour is entirely untypical of what happens on a vehicle. With the introduction of continuously varying temperature and other parameters however, the frictional behaviour of the brake also varies continuously, and it is then relevant to record all applications so that the full picture of how friction varies throughout the range of conditions can be built up. A full evaluation of the behaviour of a friction material can thus be achieved which is in fact much more comprehensive than can be easily achieved on a vehicle road test, where it is also conventional to ignore the behaviour of the brakes between performance tests, other than by recording the drivers subjective impressions. To this end it was decided to record all brake applications, and to facilitate the interpretation of results they were recorded on a twin channel chart recorder in the form of torque/time curves together with a temperature/time curve on the second channel.

8.2. Redundancy of conventional performance tests

Again referring to conventional testing it has been customary to measure torque/time curves over a range of brake pressures, usually 0 to 1000 p.s.i. in 100 p.s.i. increments at various intervals during a test.

Because this is time consuming it is only economic to select a few salient points such as initial cold, after bedding cold and hot, and pre and post fade test both hot and cold, assuming this to be a reasonable sketch of the material behaviour. Performance tests are done rather than measuring single applications in order to obtain a more reliable measure. However, the availability of a continuous monitor of friction through the operating conditions means that a group of adjacent applications can be taken as representative of the average coefficient of friction at any part of the test schedule, and this is available without the need for manual plotting of performance tests at discrete points in the test. It was therefore considered unnecessary to include any performance tests in the test schedule.

8.3. Ultra short test charts as an aid to data handling

In Fig. 16 a length of chart is shown representing both torque/time and pressure/time curves of the form produced in the tests described in 3.1.

These were interpreted manually and converted into the form shown in Fig. 17. It was considered that no important data would be lost if these were replaced by a single torque/time curve as shown in Fig. 18, (see para. 9.2.1.) together with the temperature/time curve as described in 3.1. It can be seen from Fig. 18 that the shape of any individual brake application can still be clearly seen, and that additionally an overall picture is presented of the frictional variations with bulk temperature. Accordingly this method of presentation was found acceptable for a time.

8.4. Problems of handling charts of variable length

In Fig. 18 the chart motor is actuated by the brake pressure relay so that the chart ran only when the brakes were applied, leaving no space between recorded applications. The temperature record is taken from the second disc rubbing thermocouple thus serving as an independent cross check on the temperature control. Because the time for which the chart motor was running was dependent on the coefficient of friction of the material under

test the chart length for a given circuit was to a first order of approximation inversely proportional to the time averaged coefficient of friction. See appendix 4. This resulted in one very useful advantage and one serious disadvantage. Firstly, by measuring the chart length an easy method was available for estimating the average friction level for the material, which could also be used as a completely independent cross check on the torque recording instrumentation. Secondly, the comparison of two materials of different coefficient of friction was made difficult because variable chart lengths prevent the superimposition of the two results, Fig. 19. After a time a method was conceived by which the best of both worlds could be achieved. It was necessary to record brake application pressure to ensure that no errors or malfunction had occurred during test, and the pressure chart was therefore actuated by the brake application relay so that its length would vary with coefficient of friction and could be used for averaging and cross checking Fig. 20. The torque recording was transferred to a second XY plotter as described below.

8.5. Introduction of a recording XY plotter

It became usual practice to read the friction level at various pre-selected temperatures and to plot these manually as a friction temperature graph. In order to facilitate this procedure the temperature/time profiles were altered for a period to contain short periods of constant temperature operation as shown in Fig. 21.

The resulting graph proved to be quite informative and characteristic of the material under test, but this process was time consuming and a great deal of valuable information remained unused. In fact this technique was directly contrary to the desire to retain a complete and comprehensive record of material behaviour.

However, it was clear that such a wealth of data which was so readily available, should not be discarded lightly and thus a considerable data handling problem remained unsolved.

The need was seen for a means of classifying results and plotting them automatically in such a way that a comprehensive and easily absorbed test result was generated. Individual test results could of course be classified in terms of any of the test parameters, but the greatest call was for graphs which showed as clear a picture as possible of the variation of coefficient of friction with temperature.

The idea was conceived that a second XY plotter could be used to record torque, and that if the output from the torque measuring device was fed to the Y amplifiers, and brake operating temperature to the X amplifiers than any individual brake application would be displayed as a torque/temperature curve. It was found that the appearance of the torque/temperature curve was similar to the conventional time based curve Fig. 22 and that superimposing several applications gave a good interpretation of the changes of friction between applications as the operating temperature varied over the range Fig. 23. It was then decided to superimpose a full circuit of 200 applications and the result in Fig. 24 shows that a useful envelope was formed of the friction/temperature relationship which not only gave a digestable overall picture, but could also be used to study the individual brake application characteristics where necessary.

SECTION 3.

PERFORMANCE OF PROTOTYPE MACHINE

CHAPTER 9. RELIABILITY OF RESULTS, CONCEPT OF CROSS CHECKS

9.1. Importance of cross checks

Experience over many years of testing friction materials has shown that results frequently differ from the material designer's expectations.

Probably because friction and wear can be grossly affected by uncontrollable factors like surface contamination and surface chemistry generally, and also because the mechanism of friction and wear are only incompletely understood, reliability in testing procedures is of paramount importance.

An unexpected test result could also arise due to some uncontrolled factor in the composition or manufacture of the material samples, or even in the variability which can always occur in the naturally occurring raw materials. The ideal position in which a friction material tester could place himself is one where he could retrospectively check that all the conditions of test had been under control after the event when suspicion arises over some result. This facility would be of extreme help to the material designer since he could then direct all his attention to finding the fault elsewhere, without the nagging suspicion that perhaps there was no fault in the material at all, but only an error in testing.

Accordingly it was decided to incorporate as full a cross checking system as possible, as a result of which, the enhanced confidence achieved has been instrumental in the detection of variations due to :- Drum and disc iron, direction of rotation of disc and drum, effects of ageing of cast iron, effects on the metal member of standing for period of hours to days, and a large number of unsuspected causes of variation of the friction material due to both preparation and composition.

9.2. Systems for cross checking

The most important things to cross check are clearly the measurement of coefficient of friction, and the amount of material worn away.

The next most important cross check is that these parameters have been measured under the correct conditions namely :-

1. That the coefficient of friction was measured at the correct value of rubbing speed, temperature and pressure, and after the correct sequence of previous history.
2. That the amount of material worn away was done so by dissipating the correct amount of energy at the correct rate and at the correct temperature, and that these were achieved whilst rubbing the friction material for the correct distance.

Partial success in these aims was achieved as shown below.

9.2.1. Coefficient of friction

The coefficient of friction of disc brake pads is a derived function of torque, clamping load, and radius of action of the centre of pressure

where $\mu = \frac{T}{Lr}$ where T = Torque
 L = Clamping load
 r = Mean radius of the centre of pressure

The value of r is assumed to be constant for a given type of disc brake, and although there is some ambiguity in its position it is conventional to assume that it lies on the centre line of the actuating pistons, and deviations from this assumption are conventionally accepted as being synonymous with deviations in the assumed value of μ . In practice a constant check is kept on possible variations of the radius of action of the normal load by observing the distribution of wear over the pad surface. Again however this is not an unambiguous indication that r has changed and can only be taken as a lead in conjunction with other evidence.

Coefficient of friction is therefore considered to be proportional to torque, and for fixed values of applied pressure, torque is taken as a measure of μ . As mentioned in Chapter 3.4. the average brake torque is related to the total integrated braking time, and following the successful use

of torque chart length as a measure of average μ , a digital timer was introduced actuated by the brake application and release relay. Thus a digital read out was available which could be converted into average coefficient of friction. If a test result was recorded in which some suspicion could be directed towards the recorded values of friction, a line could be drawn through the result, corresponding to the calculated value of μ average, which would clearly show up any discrepancy, See Fig. 25.

9.2.2. For Effective inertia of the machine

Should the effective inertia of the machine be in error either by coupling in the wrong combination of flywheels, or by excessive friction in the machine bearings then the incorrect amount of energy would be dissipated by the brakes, and the wear rate measure would be in error. It is also of course possible that slight errors might also occur in measurement of coefficient of friction.

To cross check against this possibility the integrating braking time could again be referred to, and if the braking time was large compared with the measured value of μ then either extra inertia or extra speed could have been employed. Discrimination could however be achieved between errors in inertia/speed or μ measurement since an increase in inertia or speed would also be accompanied by an increase in total test time, by virtue of the additional energy dissipated, which was also recorded by digital timer for this purpose.

9.2.3. For Braking Application speed errors

Within a test it is never necessary to change inertia since a test is designed to simulate a vehicle of fixed inertia. Thus although the effects of speed and inertia cannot be separated by examination of the results, it is easy to do a physical check on inertia used and should this be found correct, any errors can be attributed to errors of speed setting.

Discrimination between speed and inertia errors can also be achieved by considering the errors in consecutive circuits comprising the various

parts of a test.

Since speed settings are altered between circuits, to represent the different driving conditions of different levels of duty, errors in speed settings would have a duration equal to the time between changes in speed settings. Errors of inertia on the other hand would not fit in with this duration ; and errors due to bearing friction would change progressively over a number of circuits.

9.2.4. Cooling rate

Control of the test schedule by temperature, as has been said before, renders the consistency of cooling rate relatively unimportant. However, consistency of total test duration is monitored so that long term trends can be spotted easily and if necessary acted on.

9.2.5. Reproduction of temperature profile

Chapter 6.2.2. describes the method by which temperature is programmed. It shows that the pen of the controlling XY plotter has been replaced by an electrical contactor which closes an actuating circuit with the copper profile. In order to monitor the fact that this profile has been faithfully followed, the top half of the XY plotter bed carries a strip of graph paper on which a pen rests. This pen is attached to the XY plotter carriage and therefore will record any misbehaviour in temperature control.

Fig. 26 has been included to show the effect of misbehaviour due to contamination of the copper profile together with the friction/time curve for the same circuit. Clearly the temperature monitor was unnecessary when results were presented in this form, but transfer to XY plotter derived results necessitated this cross check. Results are presented in this form to demonstrate more clearly the effect of a programme failure on the friction results.

9.2.6. Measurement of temperature

As mentioned in Chapter 6.2.1. two identical thermocouples are employed to measure brake disc temperature and these are arranged to always

press onto the disc at the same load. They are arranged to operate a warning system if their outputs differ by an amount exceeding that thought reasonable for a given type of test.

Additionally they are used respectively to drive the dynamometer control system and to actuate the XY plotter which records the friction results. Thus if the plotted results do not appear over the correct range of recorded temperature then a discrepancy occurred during the test, and a special investigation may be warranted.

9.2.7. Brake rubbing in the 'release' position

Should the brake rub in the off position an increase will occur in the test duration due to the additional time required to dissipate the extra work done during the nominally 'off' condition. However, the integrated braking time will remain unaffected since braking time is only affected by the torque generated. Thus if the total circuit duration lengthens without an increase in braking duration (related to the measured average torque) then it may be concluded that the brake must have been rubbing in 'off' position. Thus by careful comparison of the relationship between average coefficient of friction and integrated braking time and the total circuit duration a useful cross check is available as to whether the brakes were rubbing between applications. It might be thought that the effect of increased duration would be augmented by the additional time required accelerate the flywheels through the greater speed range which is in turn caused by rubbing brakes, but on closer inspection this is not the case since this effect only causes a slight reduction in brake temperature at the point of application. This therefore results in a slightly lower brake release temperature and no overall effect on the cycle time. Thus a quantitative measure is available of the amount by which the brakes rub, which could in principle be used to discount the accompanying increase in wear rate.

Should the brakes rub between applications to a more significant

degree the effect will eventually be observable on the torque records which will read a slight positive value between applications. Confusion of this effect with the effect of a zero or sensitivity shift in the torque recording mechanism is avoided since between many applications the flywheels come to rest, so that the base line of a torque recording in which the brakes rub between applications has two levels, the true zero torque reading and also the torque generated during the rubbing period.

9.3. Failure to find a suitable cross check for application pressure

The only parameter for which no cross check has yet been devised is that of application pressure or actual clamping load when the brakes are applied. Hydraulic pressure supplied to the brake is cross checked by setting the test conditions up on a Bourden tube pressure gauge, and recording the pressure on a second Bourden tube instrument. However hydraulic seals are never 100% efficient and other losses can occur due to the piston and cylinder rubbing as a result of side loads being applied to the piston as the torque generated by the pads is partially transmitted to the pistons. Thus one is never quite sure that a constant, high percentage of the applied hydraulic pressure is transmitted to the pads under test. Static measurement of seal efficiency plus the fact that most of the torque generated is taken up by the caliper/back plate abutment suggest that little or no trouble is caused from these effects, and experience has shown that residual unexplained variations can only be of negligible value. However, it would be advantageous if an independent cross check could be devised.

Static calibration by means of a load transducer temporarily replacing the disc is of no value, since no substitution can be devised to replace the effect of side loads due to torque, nor can the effects of vibration and pulsating loads due to circumferential variations of disc thickness be reproduced. This type of cross check has not therefore been tried. The introduction of resistance strain gauges to the caliper yoke has been considered, as has the provision of a dial gauge on extension arms supported on the

cylinder heads of the caliper.

Errors due to high temperature, temperature variation, temperature gradients and uneven distribution of temperature over the surface combine to suggest that electrical strain gauges mounted directly on the caliper yoke would prove to be a major development problem in itself, the return for which would not warrant the effort required. Vibration of the whole system is such that again the use of extension arms would cause more problems than they would solve, and therefore all attempts to cross check the pad clamping load were abandoned, and this parameter remains the only one for which an adequate cross check has not been devised.

9.4. Torque measurement cross checks

The end point of the whole brake test is to evaluate torque generated, and thickness loss due to wear as reliably as possible. A novel method was therefore devised to minimise errors in torque readings, together with an arrangement of the electrical circuits which displays errors of sensitivity as a continually monitored zero shift. These are described in detail in the next chapter.

CHAPTER 10. TORQUE RECORDING

10.1. Use of a novel principle to reduce errors

The torque generated by the disc brake caliper was transmitted by direct coupling to a torque arm of known length. A strain gauged rectangular section steel bar carried the load as a cantilever in bending against a rigid mechanical stop. Strain elements were placed in a bridge circuit as is conventional. The method employed to minimise errors depends on the fact that most materials exhibit coefficients of friction of around 0.4. Thus, since the majority of brake applications are made at a constant clamping load most measurements of torque are similar and equal to $\mu r L$. Where μ = coefficient of friction, r = the radius of action of the pads and L is the total clamping load applied to both pads. If the recording instrument develops an error in sensitivity only, then the magnitude of this error at zero input is zero. By arranging that the input to the instrument is zero when $\mu = .4$ the effects of changes in sensitivity are minimised and their presence is shown by a shift in zero reading. Changes in sensitivity at coefficients of friction of other than 0.4 will still be finite, but their magnitude is reduced by a factor of $\left(\frac{\mu - 0.4}{\mu}\right)$

In practice the XY plotter, which is a potentiometric instrument with full zero suppression, was set to read 0.4 with the input short circuited.

The strain bridge circuit was then balanced with a dead weight load on the torque arm equivalent to the torque at $\mu = 0.4$ and the XY plotter placed in circuit. Under this condition the XY plotter was showing the correct reading with the torque output from the machine equivalent to the average expected value of μ . With the load removed from the torque arm the XY plotter was then adjusted to read zero by adjustments to the sensitivity control not by changing the zero suppression.

This procedure was so simple that it was found convenient to calibrate before and after each circuit, and it was found in practice that within this

time span only small errors in zero position occurred.

10.2. Discrimination between zero and sensitivity errors

When slight shifts in zero readings were subsequently observed it was necessary to distinguish between changes in zero setting and sensitivity by reloading the torque arm mechanically, after which any minor errors could if necessary be corrected retrospectively. It was found in practice that the combined effect of early warning of drifts in sensitivity, and the error reduction factor of $\left(\frac{\mu - 0.4}{\mu}\right)$ resulted in no errors ever occurring which were of a magnitude worth correcting. Friction measurement however, is such as to put a premium on positive evidence of the absence of errors, rather than merely no evidence of their existence.

10.3. Facilities for retrospective correction of inaccurate results

Dynamometers are run on a 3 shift basis and on the two night shifts no technical supervision is available. The cost of two shifts of operation is £48 and if a fault occurs during the night a full two day test may well be discarded. However frequently a machine is calibrated, it is not possible with conventional calibration to recover the information between the last two calibrations once a fault is found since it is not possible to determine the point at which a sensitivity shift started, nor the rate at which it changed. With the combination of zero errors and sensitivity changes it is possible, assuming that only one type of error occurs at any one time, to back track and locate the point at which a change occurred together with the rate at which the change took place and apply complete correction to the existing results. Thus no gaps remain in the total test data, which may on occasions avoid the necessity to repeat a whole test. Fig. 27 shows a result in the form of a y/T record for ease of interpretation, in which the recorder sensitivity was intentionally varied by $\pm 20\%$ during a test. It may be seen that the readings of μ varied to the order of 2 - 3% and the change in 'between applications' readings provides facilities for complete rectification.

CHAPTER 11. PROTOTYPE PERFORMANCE

11.1. Reason for performance check at prototype stage

It was appreciated that at this stage the equipment was not developed into its final form, but before undertaking to spend more time, effort and money it was appropriate to examine the performance of the whole machine.

The proving trials fell naturally into two groups :-

- a. To assess the electrical and mechanical functioning of the controller, the values of the various control parameters chosen, and mutual compatibility of these parameters.
- b. To determine the degree to which a test result could be repeated in terms of friction measurement, frictional behaviour, and durability.

11.2. Initial trials on a range of typical brake materials

The preliminary tests consisted simply of a series of medium duty circuits performed on a variety of standard types of disc brake linings. No difficulty was encountered except that the surface of the copper profile had to be kept very clean in order to ensure reliable electrical contact.

It soon became evident that during the first circuit on new samples of unbedded material a considerable fall in friction was recorded both with respect to the initial value of friction and also to the stabilised friction level in subsequent circuits. This behaviour was considered to be representative of initial fade which is known to take place during tests on a vehicle, and it was interesting to note that the fade under these moderate conditions was always fully recovered to a normal level by the end of the first circuit. The machine discriminated easily between different types of friction material, and after the effects of initial fade had been overcome, many materials showed variations in friction level in phase with the imposed temperature variation as in Fig. 18.

11.3. Extended trials on a pair of similar brake materials

The essential feature of the programmer was the degree to which it

could detect and characterise a small difference between very similar samples consistently. The first extended trials therefore, were designed to study this aspect of performance.

A pair of samples was selected from each of two batches of nominally the same material in the knowledge that normal random variations of factory produced material would ensure that small, but only small differences would exist between them. Selection of nominally the same material also ensured that as far as possible both samples could be expected to respond in a similar manner to effects of previous history during a long duration test.

The chosen procedure consisted of a series of medium duty circuits performed alternately on each pair of samples, followed by a similar programme at heavy and then at light duty. Alternate sequencing of the circuits was chosen in order to minimise the effects of time dependent factors such as disc ageing on the comparison of the two materials. The calculated average value of coefficient of friction and also wear for each moderate duty circuit is plotted in Fig. 23. which serves to demonstrate the relatively high degree of consistency obtained, sample (A) having slightly higher friction through most of the test and also correspondingly higher wear rate.

11.4. Precision of Wear Measurement

Unexpectedly good repeatability was achieved in wear assessment, and it became clear that residual errors were caused largely by the individual operatives handling of the micrometer. This was evidenced by the fact that where two different operators happened to measure pads at the beginning and end of a test consistent errors were introduced. It was found that some operators consistently used higher torque in using the micrometer than others and if these operators measured initial thickness the wear losses were recorded low. To counteract this effect micrometers were replaced by Swiss clutch driven digital micrometers made by 'Etalon' with an immediate improvement in the repeatability of wear measurement.

Fig. 29 shows a progressive change in wear rate as successive moderate duty tests are performed on a given material the scatter about the line being the error of wear estimation due to testing.

11.5. Repeatability over a time period

It is more difficult to achieve good repeatability in tests on friction materials when these are conducted over a long time span than when they are done consecutively. Fig. 21 shows the results of a preliminary exercise in which two tests were measured consecutively, after which a further pair of tests were performed on the same material after a period of two weeks had elapsed. The results suggest that the two week interval had not resulted in a significant change in the ability of the machine to repeat an earlier result. In order to investigate the effect of elapsed time more thoroughly, Fig. 30 shows the results of a series of moderate duty tests done on two similar materials where one series of tests were done consecutively and the other done with an interval of one week between each tests. The results show differences which are clearly real and due to the effect of material recovery during each week of standing. To demonstrate this a third set of tests is included in which a new sample of the material was also tested at weekly intervals.

11.6. Standard deviation in friction and wear rate evaluation.

In order to evaluate the precision with which the dynamometer could measure the coefficient of friction and wear resistance of friction material two difficulties have to be overcome. Firstly, in contrast to the measurement of most engineering quantities it is not possible to make two samples of any material to a known standard of similarity in their behaviour as friction materials. The reason being that there exists no method of measuring these parameters with sufficient precision except perhaps the machine under consideration. To resort to materials of pure chemical composition does not provide a solution since no pure substances behave in any way approaching a suitable friction material.

The second reason is that the use of the same samples of material is precluded, since although it is well known that the performance of a test for friction and wear will alter the characteristics of the test piece it is not known quantitatively what the magnitude of the change might be. It was decided therefore that the problem was only soluble statistically, and that the standard deviation of pairs of samples is equal to $\frac{1}{\sqrt{2}}$ times the standard deviation of single tests.

Since the testing time would be considerable it was decided to combine the measurement of precision of testing with an exercise to measure the variation inherent in factory produced materials which was required for other reasons.

Several samples were chosen from several batches of factory produced materials of four different types, each type being a material in current production. These were tested in random order, each test being performed twice for the purpose of assessing repeatability. Each test consisted of three moderate duty circuits ; the first of which was disregarded because new pads were clearly more variable than the same pads after bedding. The whole programme lasted for four weeks (3 shifts) or 480 hours, each individual test of 3 circuits taking about 12 hours.

Friction and wear results were subjected to statistical analysis of variance to determine the sources of variation. The standard deviations of the test results for each of the four materials are shown in the table in Fig. 31.

The total standard deviation within sample includes the combined effect of variation from two sources, random variation due to the variability of a sample as it is worn into the substrate, and the variation arising from variability within the machine and its programming.

Clearly, if the whole source of error within pads was due to the machine, then the standard deviation due to the machine would be only 0.0032 μ and 0.0002in for wear measurement. These figures were considered

to be quite encouraging, but in order to separate the two sources of variation several compound pads were constructed. Material from eight samples was removed from their metal back plates and cut into quarters such that two diagonally opposite quarters were salvaged from each pad, and these were reassembled to form two pairs of samples, each pair containing one quarter from each of the original eight samples. This was repeated for several batches of material and the samples were retested in a randomised programme.

A statistical analysis of the coefficient of friction showed that resulting from this procedure the within sample standard deviation fell from 0.0032 for whole pads to 0.0023 for quartered pads. Since the contribution of random sample variation to the overall variance would be expected to decrease by a factor of four, it may be calculated that the contribution from machine and programming errors yields a standard deviation of 0.0019 by the following calculations :-

If σ_s^2 is the contribution of sample variation to the within sample variance and σ_m^2 is the contribution from machine and programming errors, then $\sigma^2 = \sigma_s^2 + \sigma_m^2$

$$\text{Thus for whole pads } 0.0032^2 = \sigma_s^2 + \sigma_m^2 \quad \text{--- (1)}$$

$$\text{and for quartered pads } 0.0023^2 = \frac{\sigma_s^2}{4} + \sigma_m^2 \quad \text{--- (2)}$$

Solving (1) and (2)

$$\sigma_s^2 = 0.0026 \mu$$

$$\sigma_m^2 = 0.0019 \mu$$

Similar calculations for wear yield a value of $\sigma_m^2 = .0002$ in wear estimation.

SECTION 4.

THE FULLY DEVELOPED MACHINE

CHAPTER 12. COMPLETION OF DESIGN TO OPERATE WITHOUT TECHNICAL SUPERVISION

12.1. Extension of flexibility

The success of the operating trials on the prototype unit was so encouraging that it was decided to manufacture six further control units to operate six more dynamometers all of which were inertia type, but which covered a range of inertia capacities from 700 lbs. ft.² to 30,000 lbs. ft.². Envisaging that this represented considerable capital outlay a control console was designed incorporating all the facilities available on the prototype with additional safety devices to enable the units to be operated on a three shift basis with no technical personnel on the two night shifts, and extended flexibility required to cover a multiplicity different machines. In order to minimise construction cost it was decided to sub-contract the construction and to maintain secrecy it was necessary to modularise the design and sub-contract different modules to different constructors. To reduce the cost of components it was decided to make one XY plotter carry out the function of both the programming and the recording XY plotters, and to make the remaining unit do its own monitoring and to cross check its own temperature control.

12.2. Multiplexing of XY plotters

Considering the function of the two XY plotters in the prototype unit, the programming instrument functions during the period between the end of one brake application and the initiation of the next, and the recording instrument operates only during a brake application. Also there is a short period of acceleration of the machine during which time neither instrument is operational which is therefore available for monitoring the brake application temperature.

This was achieved with the plotter carriage arrangement shown in Fig. 32. The temperature signal was fed continuously to the X amplifiers and the torque signal to the Y amplifiers, the temperature profile being

rotated through 90° with respect to the base plate. The carriage bore a motor driven threaded rod parallel to the Y axis, which in turn carried a photo cell used to detect the edge of an transparent profile illuminated from behind, which replaced the etched copper profile used in the prototype. The profile was cut from a sheet of aluminium and was positioned to correspond with the temperature scale as shown in Fig. 32. A light source diffused by a ground glass screen behind the profile activated the photo-cell which in turn triggered the main motor relay. Between applications the photo detector was stepped by means of a single turn of the threaded rod and steps were counted by the counter shown.

The use of this mask type profile in which the photo cell detected the position of the uncovered part of the boundary afforded a fail safe system in that failure of the light source caused the programme to discontinue. It was found in practice that this type of profile proved more satisfactory than the etched copper strip which had occasionally, due to contamination of the conducting surface, failed to trigger the main motor relay at the correct temperature.

12.3. Monitoring facilities

In addition to the recording pen and photocell, the carriage was also fitted with a magnetically operated pen actuated by the same relay as that used to trigger the main motor solenoid, so that a dot of red ink was placed on the chart at the time the main motor was started. This provided a permanent record on the friction temperature graph of the performance of the temperature controller instead of on a separate sheet as previously.

Parallel lines showing the correct location of the peaks of the temperature time graph were pre-printed on the record sheets to assist the early detection of faults and to provide an easy reference system for retrospective validation of each test sheet. The whole modification was made in such a manner as to clip quickly and simply on to the basic XY plotter

to facilitate the interchange of units. Fig. 33 shows a typical graph in the form of a friction/temperature envelope with the temperature monitor and parallel location lines.

12.4. Torque measurement

Torque measurement by means of a strain gauged cantilever bar was retained for dynamometers carrying passenger car brakes, but for those carrying brakes for heavy commercial vehicles, commercially made load cells were substituted. Both systems depend on a bridge circuit and both were operated as described in Chapter 10.

12.5. Additional facilities

12.5.1. Integrated braking time

The integrated braking time, which in the prototype instrument was deduced from the length of the friction/time charts was subsequently measured directly by a digital timer with improved reliability and precision.

12.5.2. Total test time

In view of the success of such a simple independent cross check, the total duration of each test was also recorded. Errors in the temperature control were found critically to affect the cycle time especially at the low temperature ends of the profile where cooling was slow. A combination of total test time and total braking time could therefore often be used to locate the source of problems.

For example, a changed test time without change in the braking time indicated changed cooling conditions, a similar change in both test and braking times indicated line pressure errors, and a change in braking time with a larger change in test time indicated speed error.

12.5.3. Integrated testing time

A third digital time counter was provided to sum the total operating time of the unit so that regular scheduled maintenance could be carried out. In practice a schedule has been drawn up in which routine overhauls are performed at 1,000 hrs.

12.6. Temperature Monitoring

Because the temperature of application of the brake is the dominant factor in measurement of wear resistance of pads it was decided to take precautions in addition to the continuous monitoring of temperature as described in 9.2.6.

Examination of the cross check described above shows that failure of the thermocouple and its carrier to follow disc temperature is already covered, but not the associated amplification circuits of the XY plotter. However the provision of a re-transmitting slide wire to the XY plotter enables a voltage to be generated proportional to the position of the plotter carriage along the X axis. Thus if this voltage is used as an indication of not only the thermocouple performance, but all its associated electronics, and compared with the output from a second thermocouple operating on the same radius on the disc, then correspondance between these two voltages will provide a cross check on the performance of the whole temperature measuring and temperature controlling system. This was available by switching the machine off when the indicated temperature difference exceeded 10°C and sounding an alarm signal. The circuit used is shown in Fig. 34.

12.7. Additional fail safe systems

The introduction of three shift working without close supervision necessitated the addition of further safety devices.

12.7.1. Over speeding of main motor

On some dynamometers the main accelerating motor is capable of running to a speed at which either the flywheels would burst or the bearing would sieze. To prevent this an interlock was provided so that if no brake application had been triggered before the safe maximum speed was exceeded, or if no speed signal was received within three seconds of the motor starting (failure of the tachometer generator) the main motor was switched off, and an alarm signal sounded.

12.7.2. Location of chart or profile

Micro switches were provided to prevent the machine from starting if either the location of the XY plotter chart or its controlling profile were incorrect. Also the test was halted in the event of the speed sequence being incorrectly set such that an application speed was lower than the release speed.

12.8. Selection of application and release speed

Although a uniselector was quite adequate for programming speeds, performed well on the prototype controller, and provided the additional facility of stepping the controller along the X axis it was somewhat difficult to re-programme the sequence of operations. To facilitate the more frequent re-programming required for a universal dynamometer controller covering a wide variety of test schedules, the uniselector was replaced by a more conventional patch board in which application and release speeds could be selected over the range zero, to 1500 r.p.m. This system also made programming easier, in that if an application was programmed on say a steeply rising part of the temperature profile which failed to raise the temperature sufficient to clear the profile for the next brake application, it became an easy matter to increase the application speed or reduce the release speed without rewiring.

This facility was particularly useful in test sequences where it was required to limit the energy dissipated in individual applications whilst at the same time generating a rapid rate of rise of temperature with time. On the previous system this could be achieved, but only at the expense of frequent double applications, where one application was triggered immediately after the release of brakes on the previous application. The circuit used is shown in Fig. 35.

12.9. Manual over-rides

The final feature of the modified controller was the ability to switch from temperature control to a constant time cycle control whilst still re-

coding against temperature to facilitate fade tests and other proprietary test schedules. Override facilities were also available to maintain application speed, release speed, or pressure, independent of the programmed sequence. The complete unit is shown in the photograph Fig. 36.

CHAPTER 13. SELECTION OF TYPICAL RESULTS

The type of data obtained from the machine is illustrated in Figs. 36 - 40 by a few examples of some aspects of the behaviour of typical materials used as disc and drum brake linings.

13.1. A complete test schedule

In Fig. 37, three circuits are shown representing typical light, moderate, and heavy duty behaviour of a normal commercially available disc brake material. Each circuit consists of 182 brake applications made over a range of temperatures at 200 p.s.i. hydraulic pressure together with 12 applications interspersed through the circuit at 300 p.s.i. The individual torque/temperature curves form an envelope showing the overall trend of coefficient of friction through the range of temperature. High values standing out from the general pattern represent those applications made at 300 p.s.i. and of course the scale of friction refers only to the 200 p.s.i. application, those at 300 p.s.i. being $3/2$ times scale size.

A complete test consists of seven such circuits usually in the sequence two light, two moderate, two heavy, followed by a final light after heavy designed to show changes with previous history.

The complete test has a duration of about 24 hours including the time required to make seven measurements of wear losses sustained by the pads. Fig. 37 D shows the temperature profile for a medium duty circuit in the position normally occupied by the monitor together with three vertical lines locating the expected position of the peaks for each duty level. In order to discriminate between results recorded during the first and subsequent excursions to high temperature on each circuit, the recording pen colour was changed manually from red to black after the machine had completed the first peak in temperature. This facility proved very useful when examining materials which exhibit initial brake fade but in the particular example shown, little or no separation was in evidence. The whole result forms a

very clear picture of material behaviour, and in particular shows the progressive changes which occur in performance as the duty level is increased.

13.2. Changes in disc behaviour

A second example of behaviour Fig. 38 refers to changes which occurred due to progressive changes in the cast iron of the brake disc as a series of tests was performed on the same friction pads. The friction material used was of the same type as that used in Fig. 37, but in this case new samples of friction material were used for each test and the test was comprised of two medium duty circuits. The series commenced with a brand new disc and a very high coefficient of friction resulted Fig. 38 A. The object of testing each pad material for two circuits was to eliminate variations due to the initial bedding of the pads as surface irregularities are removed and the figures shown represent the second circuit of a pair. As the series continued and the disc became 'conditioned' the coefficient of friction fell progressively until apparent stability was reached at about the 26th test.

An examination of the full series of 36 tests, however, revealed that even after 72 circuits changes in mean friction level of the order of 0.001 per circuit were still occurring.

A comparison of the results in Fig. 38 C and D with the medium duty circuit of Fig. 37 B which was carried out on another well used disc, shows marked similarity between the two tests.

The reason why cast iron which was a normal grade 18 grey iron should change under the conditions used is not yet known. Micro sections through the disc revealed no sub-surface transformation and the nominal surface temperature was never sufficiently high to cause any metallurgical changes. The possibilities of very high surface temperatures has been the subject of much speculation, but the subject falls outside the scope of this thesis. However superficial examination of the problem suggests that surface contamination by

material from the friction pads in the accepted sense is not responsible for the changes - elucidation of this problem might well form the subject of further work.

13.3. Investigation of initial fade

As a further example of the type of data available from the machine Fig. 39 shows the dramatic but progressive changes which occur in initial fade as small percentages of a commonly used ingredient were increased uniformly from Fig. 39 A to D.

Close examination of Fig. 39 A shows that as the temperature increases, slight fade in friction occurs, but the majority of fade is delayed, and appears during the falling temperature region after the first peak. Subsequent peaks of temperature give rise to smaller amounts of fade until at the end of the first circuit most of the fade has been eliminated by previous history. The sequence of applications is indicated by the arrows. As the composition of the pad material is changed progressively from Fig. 39 A to D the whole effect changes markedly in magnitude but invariably, by the time the third temperature peak was reached the initial fade had been 'heat treated' out of the pads. A second similar test on the same pads showed that only in the case of zero additive was there any recurring residual fade, and there only on the second rise in temperature.

13.4. Behaviour of drum brakes

Fig. 40 shows by comparison the different type of behaviour exhibited by a large commercial vehicle drum brake. It may be seen that considerable changes occur in coefficient of friction which are of a less transient nature as the duty level is increased to cover higher temperatures. There are two reasons for this, firstly the type of friction material used for large drum brakes is more sensitive to temperature because they are made to exhibit greater conformability in order to maintain a good contact area. Good contact area is necessary in order to avoid 'strip braking' and consequent heat spotting of the cast iron drums, and the nett result of these

considerations is that the synthetic resins used in large drum brake linings are softer and therefore less thermally stable than those used for disc brake materials. Secondly in spite of the use of softer resins, the linings can still not be sufficiently soft to change radius as the drum expands thermally. Thus as higher temperatures are reached contact between lining and drum tends to be concentrated towards the crown of the lining. This means that although the lining may contact the drum over its whole length, the pressure distribution departs from the cosine distribution which would result from continuous wear at constant temperature, Ref. 23 and tends to zero at the leading and trailing edges. Thus the 'shoe factor' of the brake decreases as the drum expands thermally contributing to the increased sensitivity to temperature in Fig. 40.

It may be seen from the friction scale in Fig. 40 that in contrast with the disc brake results shown earlier, coefficient of friction is not linearly related to torque for a constant actuating pressure. In order to provide a scale of coefficient of friction on the results which are of course torque output from the brake, it is necessary to make some assumptions about the pressure distribution along the length of the linings. In spite of the fact that thermal expansion of the drum relative to the lining and shoe will affect the pressure distribution, insufficient knowledge exists to evaluate the effect quantitatively and in any case the magnitude of the effect varies from lining to lining and with flexibility of the whole brake mechanism. For this reason the scale of coefficient of friction is calculated on the assumption that a normal pressure distribution exists and is to some extent therefore nominal. The calculations involved in evaluating a scale of coefficient of friction are included in Appendix (5).

13.5. Fade and recovery tests

13.5.1. Conventional type of test

A conventional fade and recovery test is designed to yield information on the loss of brake effectiveness as rapid applications of the brake are

made resulting in abnormally high temperatures. This is done by measuring the torque output from the brake at constant application pressure over say thirty cycles at 45 second intervals such that at the end of the test a temperature in the region of 300°C is reached by the brake drum. The test is usually performed without cooling air in addition to the normal convective cooling, and is followed by a further series of say 10 brake applications at much longer interval to measure the recovery of the brake as the temperature falls back to ambient. Temperature of the brake is measured throughout and the temperature time curve both rising and falling is superimposed on the result of torque/application number so that the effect of different rates of rise of temperature can be taken into consideration when evaluating the results. This is necessitated by the difficulty of maintaining a constant rate of change of temperature under changing environmental conditions. The shortcomings of this procedure are two fold. Firstly it is not possible to present full information on the variation of torque within each application and secondly it is not possible to make correct allowances for variation in rate of change of temperature between one test and another since the relationships are not well known. A typical result of a conventional fade test is shown in Fig. 41, in which the arrows represent an attempt to demonstrate variation of torque within an application, and the recorded temperature is superimposed as described.

13.5.2. New type of fade test

Fig. 42 shows the same test plotted in terms of brake applications, (again at constant time intervals) against temperature. The picture presented shows a much clearer relationship, including the variation within brake application, and the recovery test is superimposed in red for clarity.

In order to eliminate the effects of varying rates of change of temperature the procedure can now be standardised by cutting a profile to match the particular results achieved in the above test and using this as pattern for future tests. Then by programming the XY plotter/controller to repeat

the test on a temperature basis instead of constant time cycle a precise control can be exerted on the temperature cycle thus eliminating the need to make subjective allowances for variations occurring due to changing environmental conditions.

13.5.3. Constant temperature profile testing

It is of course not possible to reproduce exactly the same test under controlled temperature because the linings once used will change substantially in their behaviour. Fig. 43 however shows 3 further samples of the same material tested according to a constant temperature profile.

Time did not permit the provision of an extensive series of such tests to demonstrate the improved repeatability of temperature controlled fade tests, and the cost of such a series would be prohibitive for the purpose of this thesis, the cost of a single test inclusive of bedding would be about £100 however a measure of improvement to be gained can be seen from Fig. 44. This shows a series of fade tests on a number of samples of the same material done by conventional methods. It may be seen that those tests where, due to variations in environmental conditions, the rate of rise of temperature is low, show substantially different characteristics from those where temperature rose rapidly. It is of course not possible to correct for such changes, as different materials differ in their sensitivity to rates of change of temperature.

CHAPTER 14. SOME SUCCESSFUL PROGRAMMES CARRIED OUT ON THE MACHINE

14.1. Variations in cast iron rotor behaviour

Although the dynamometer control was designed to investigate the behaviour of friction linings the improvement in precision and reliability of results soon lead to the conclusion that the cast iron rotor (drum or disc) was contributing to the behaviour of the friction pair. It had always been recognised that changes in cast iron for example from grey iron to spheroidal graphite iron, nodular graphite, or malleable iron would influence behaviour to a considerable extent. What was not previously known was that within the specification of flake graphite grade 18 grey iron, considerable differences in behaviour could be detected provided that variations from other sources could be eliminated. Close examination of results showed that two types of variation due to cast iron could be detected. Firstly a variation exists between different discs or drums made to the same specification by the same foundry, and more so between different foundries, secondly a variation of a given disc or drum as testing continues. Because the second source of variation often exceeds the first and because considerable uncertainty existed as to the validity of any test on friction materials, these variations in iron had not previously been observed. However, having eliminated other sources of variation it became clear that the variation due to iron were very considerable indeed, and did in many cases exceed the variation due changes in the friction material which were under investigation. Knowledge of the existence and characteristics of the variability in behaviour of iron suggest that their detection should have been possible before the improvements in testing described in this thesis were available. It is clear now that the reason that they were not identified lies largely in the fact that they take time (on test) to develop in many cases. Thus changes in apparent behaviour of the friction material under test did not coincide with the replacement of the rotor during a given series of brake lining tests.

They were therefore attributed, erroneously, to the unpredictability of the behaviour of friction tests generally, a conclusion which is not in conflict with the many attempts to measure friction and wear under much more controlled conditions in laboratories throughout the world.

Fig. 45 shows the results of a series of tests on brake discs of commercial origin from different manufacturers, from different foundries but made to the same specification, and from the same foundry to a given specification. The work was the subject of a short paper published in the J.A.E. and has been accepted by the industry as the first quantitative and positive evidence of the existence of such variability.

In Fig. 45 the original dynamometer results have been summarised for publication, to ease interpretation for those not familiar with the derivation of the test results.

A short description of variations with time of test is reported in Chapter 13.2.

14.2. Measurement of brake noise and squeal on dynamometer

Dynamometers have frequently been thought to be unsuited to the study of brake noise. This is because the suspension of both disc and brake assembly differs from that of a vehicle, and therefore modes of vibration may be critically changed. It is also well known that brake noise is in many cases extremely sensitive to brake operating pressure and temperature, and also that noise is frequently extremely fugitive in its appearance, no doubt due to its dependence on previous history and thermal distortion of the rubbing parts. However, the most systematic pattern of brake noise on vehicles, and probably the only pattern of behaviour which is reasonably predictable is that occurring during periods in which the brakes are cooling after a prolonged high temperature operation. This is one reason why a number of workers have drawn the conclusion that thermal distortion plays a strong part in the generation of squeal, although there are equally plausible explanations in other directions.

During the operation of the dynamometer to temperature controlled profiles it was frequently noticed that squeal occurred for short periods of a few brake applications towards the troughs in temperature profile, and that squeal would start at the threshold of audibility, increase to clearly audible, and then decline to zero just after the minimum temperature was reached. Because of the similarity between this pattern of behaviour to that experienced on vehicles further investigations were started.

It is beyond the scope of this thesis to describe the work in detail, but briefly by attaching acceleration transducers to each back-plate of the friction material, and feeding the output into a filter circuit to remove ultrasonic noise, the amplified signal was shown to measure brake noise which correlated subjectively with the occurrence of noise on a vehicle fitted with similar friction material and brakes. Fig. 46 shows a typical chart from a three channel recorder containing temperature, torque and measured noise.

Various further observations were made including the incidence of ultrasonic noise before and after audible noise was observed, the relationship of noise to $d\theta/dt$, and the relationships between noise emanating from the two pads separately. Further work showed the influence of thickness of the metal back plate on noise and the tests were successfully used to develop friction materials showing diminished propensity to noise.

14.3. Repeatability of friction material behaviour

It is commonly accepted that the behaviour of asbestos reinforced resin based friction materials are, like most other material somewhat variable in behaviour. This view arises from many sources including the known variations which occur due to chemical changes in the surfaces of the friction elements under heat and oxidative degradation ; and the changing environment in which friction experiments take place i.e. atmospheric contamination and contamination due to wear products. The view is also

supported by the often observed experimental difficulty in achieving the same results twice on the same piece of friction material. Referring back to the results shown in Chapter 13 it may also be deduced from these that the coefficient of friction at any given temperature on any given circuit covers a wide range of values and therefore contains considerable scatter. However, during the use of the dynamometer for friction material development, it was frequently noticed that odd individual brake applications which stood out from the general envelope of values were remarkably well repeated between consecutive similar circuits. This suggested that perhaps repeatability was much better than the consistency of the envelope itself indicated, and that another source of variation gave rise to the variability of the whole envelope of results.

It was recognised that the programme of speed and pressure of brake applications, although consistent from test to test was not interlocked with the temperature profile, and that the point in the programme at which a test started could vary by a few applications depending on the exact location of the temperature profile on the XY plotter bed. Thus slight phase shift could occur between temperature and brake application programme which could cause minor variations from one test to another. It was thought that this might detract from the repeatability of the whole result in some small degree and that the potential repeatability might be even better than it appeared. Accordingly a special exercise was conducted to establish the true repeatability of friction materials. First a friction material was selected which showed a reasonably high variation in friction at each temperature and run for repeated circuits until stability was reached. In all, 16 circuits were performed in the series.

Care was taken to ensure that temperature profile and application sequence were in phase for each circuit. Twelve individual brake applications were then selected at fairly regular intervals throughout each circuit and recorded on a separate XY plotter in parallel with the recording/

programming unit. The applications were selected to cover the whole temperature range and duration of the circuit so that three applications were made at each of four temperature.

Considerable variation was observed between the results from consecutive circuits even though overall stability had been achieved, and superficially the result looked disappointing. However, it was observed that the main difference seemed to be in the length of corresponding applications along the temperature axis. It was recognised that this could well be due to the effects of strip braking. Strip braking varies in magnitude from material to material and is caused by the non-uniform pressure distribution across the radial width of the friction pads, such that work is not done uniformly across the rubbing surface of the disc. Thus if the majority of the work is done at the same radius as the radius of action of the recording thermocouple a considerable increase in temperature is observed within the brake application, and if remote, only a small rise is observed. This in turn varies the length of the recorded application and appeared to account for the variability of results.

Circuits No. 9 and 12 were then chosen for manual correction of this effect as far as possible and Fig. 47 and 48 (shown superimposed) represent the resulting repeatability of individual brake applications separated by no less than 10-1/2 hours of continuous testing over a wide range of temperatures. The repeatability is now extremely good showing that in the uncorrected form, a large part of the apparent scatter, which itself is not great arises from the random variation of centre of pressure of the pads with respect to the measuring thermocouple. Clearly this is an effect which averages itself out over a number of applications accounting for the excellent repeatability of the average value for each completed circuit.

Further consideration of Fig. 47 and 48 and the reasons for the apparent scatter in individual applications in the friction envelope, shows that the real repeatability of friction behaviour must be even better than

that shown in Figs. 47 and 48. The reason for this is as follows :-
The cause of the variation in the temperature rise per application as has already been said, arises from variation in the radius of action of the centre of pressure over the face of the friction material. This in turn means that the coefficient of friction as calculated from the torque generated must be slightly in error because the calculation involves the assumption of a constant nominal radius of action of the centre of pressure.

No doubt this error would account at least in part for the residual scatter in Figs. 47 and 48, but it was considered that further investigation along these lines would be beyond the scope of this thesis.

Further work on the real centre of pressure during each application could be conducted given a knowledge of the temperature distribution across the face of the disc such as could be obtained by employing a number of thermocouples at different radii. However the precision of the friction/temperature envelope was more than adequate for the purpose for which the control system was developed. The further precision shown in Figs. 47 and 48 show considerable improvement again, and to still seek further correction would be of academic interest since the suggested precision is unprecedented, but of no real practical importance.

CHAPTER 15. DISCUSSION15.1. Achievements

The original development target for this work was to provide a rapid, reliable a comprehensive method of testing at low cost. Reliability requires that the test results be both repeatable and relevant, and relevant means in this context that results from the dynamometer must be quantitatively the same as would be obtained on a vehicle if it were possible to achieve perfect reliability on the vehicle itself.

It is the authors belief that this target has been met, but in order to provide rigorous proof, further work would be necessary to advance vehicle testing to the standard which has now been reached in dynamometer tests.

15.1.1. Correlation with the vehicle

A system has been developed for testing friction materials using proprietary brakes on a conventional inertia dynamometer. The dynamometer is automatically programmed in such a way that the test schedule is truly representative of the duty imposed on the brake when run on a vehicle under normal or abnormal conditions on the public road. Experience in testing by this technique shows that all features of behaviour exhibited on the dynamometer are quantitatively representative of behaviour on the corresponding road vehicle provided that the following conditions are satisfied :-

1. That the friction materials used on vehicle and dynamometer are carefully selected to be equivalent in every way.
2. That the metallurgical properties of the disc or drum used on the dynamometer are reproduced in the discs or drums used on the vehicle.
3. That the previous history of testing on both vehicle and dynamometer are equivalent both for the friction material and for the cast iron rotor.
4. That the effect on behaviour, of standing unused between parts of a test, say for example over night, over weekend, or over lunch time are either

made equal on both machine and vehicle or time is allowed for such transient effects to disappear before comparisons are made.

However, to demonstrate the quality of correlation with vehicle results is difficult for three reasons :-

1. It is difficult to ensure that differences in cast iron rotors and friction material between vehicle and dynamometer do not introduce uncontrolled differences.
2. Most vehicles are fitted with different types of brake on front and rear axles, i.e. disc front, drum rear or 2 leading shoe front, leading/trailing shoe rear, and all vehicles have uneven distribution of energy dissipation front to rear, usually higher on the front axle. Thus the performance of the vehicle brakes represents a combination of interacting brakes and cannot be compared accurately with the performance of a single brake on a dynamometer.
3. The control of vehicle testing is much less advanced than the control of dynamometer testing, and it is not possible, therefore, in the present state of the art to achieve reproducibility between vehicle tests which approaches that of the dynamometer.

The best evidence of good correlation is therefore derived indirectly and the following is just one example of such evidence. In many cases during vehicle testing slight imbalance can be detected between the performance of the two front brakes either by observing slight differences between the temperature of the two discs or drums, or by the vehicle tending to veer slightly to one side during braking. Whenever brakes from such a vehicle have been tested in turn on the dynamometer not only has the imbalance been reproduced, but reproduced over the correct temperature range even in cases where the imbalance has changed direction throughout the temperature range.

Figs. 49 - 55 show the correspondance between vehicle and machine results during an exercise to investigate brake pull. A vehicle was purchased on which the two front discs, made by the same foundry were exhibiting differences in behaviour such that during braking the car pulled violently

to the left. Fig. 49 shows the individual front disc temperatures during a 60 mile road circuit in which a wide range of temperatures could be expected. Clearly the nearside brake was doing considerably more work than was the off side. It was concluded that the near side disc was exhibiting untypically high friction and it was changed for a 'normal' disc.

Fig. 50 shows a second similar run of 67 miles after the new disc had been bedded and it is clear that the discrepancy is much smaller, but still present. Fig. 51 shows a third run after the off side disc had been replaced by a second 'normal' disc and rebedded. The discrepancy has now completely disappeared showing that the two discs were a similar pair.

All four discs were then re-ground on the operating surfaces and tested on the dynamometer.

Figs. 52 - 55 show the four discs tested in turn and clearly demonstrates a very large discrepancy indeed between the first two discs, and equivalent results on the two replacement discs. Thus a clear indication is given that both vehicle and dynamometer are in detailed agreement in their measurement of the behaviour of the brakes.

Many other similar cases can be quoted, but the qualitative nature of vehicle tests, and the subjective comparisons made to draw conclusions, makes such evidence unsuitable for tabulation.

However, whenever it has been suspected that a failure to correlate has existed, closer inspection of the results has shown comparisons were being made under non-comparative conditions such as at different temperatures or after different amounts of previous testing.

15.1.2. Reproducibility of results

The reproducibility of results on the dynamometer is quite unexpectedly good provided adequate precautions are taken to ensure that both friction materials are equal. Quantitatively, as is shown in the foregoing report the reproducibility can be expressed in terms of the two sigma limits between tests. The calculated values for 2σ limits in coefficient of friction are $\pm 0.003\mu$, and for wear loss in terms of thickness are equal to $\pm 0.002\text{in.}$

Figs. 56 - 66 show the actual machine results summarised in Chapter 13.2. more fully. Five or six pairs of samples were used in total out of each of six batches of material. They were tested in random order, and as has been stated showed a progressive reduction in coefficient of friction as the disc characteristics changed. Closer inspection of the results showed however that there were characteristic differences between samples from each material batch superimposed on the general trend. Two batches which showed the greatest difference (batches 647 and 404) have therefore been included to demonstrate that slight differences in raw materials or production parameters cause real differences in performance characteristics as stated in Chapter 1.4.1. and 1.4.2. Batch 404 is higher in friction, higher in wear rate, and more uniform in friction/temperature characteristics than batch 647. The series also demonstrates the repeatability obtainable in a long series of tests even when sample to sample variation within batches is still present.

15.1.3. Quality of results

A large number of brake applications must be made under representative conditions during a test of friction material in order to assess resistance to wear accurately. By automatic programming and plotting it is possible to record the friction behaviour throughout all applications in a meaningful form instead of recording only a small fraction of the work done as is the case by previous methods. By automatically arranging the plotting of each brake application, in a logical way instead of merely chronologically, it has been possible to assemble each individual result so that the whole envelope of behaviour can be assimilated by the formulator or tester at a glance. Thus an extremely comprehensive test result is presented using all available data without the need for manual interpretation or the cost of computer analysis.

To illustrate these points the complete series of machine results which are summarised in Chapter 13.3. are included (Figs. 67 to 80).

The series Figs. 67 - 73 represents increments of 1% in one ingredient

in the formulation and shows the progressive changes in performance as described in Chapter 13.3. The second series from Figs. 74 - 80 however shows precisely the same series of additions at 1% increments, but in this series a second ingredient was added at the 5% level throughout. Together, the two series show, (A) progressive changes in each series demonstrating consistent and repeatable behaviour and (B) that not only do small changes in composition have marked effects on performance, but that the addition of one ingredient interacts with the effect of the presence of other ingredients as was stated in Chapter 1.4.

15.1.4. Cost and speed of testing

A full evaluation of a friction material including friction and wear over a range of three duty levels with repeat tests to evaluate the effects of previous duty can be completed in 24 hours.

The cost of testing consists solely of the power required to drive the dynamometer plus depreciation, with the only labour cost involved being that required to fit the brake up and measure the material for wear losses. By current accounting figures the cost of a 24 hour test is £50 compared with £160 for an equivalent test by previous technique.

15.1.5. Reliability

Routine maintenance on the controller involving mainly removal of accumulated wear dust is currently performed every thousand hours of operation.

15.2. Why results are better than expected

When the work was started it was expected that a substantial improvement would be achieved both in relevance and in precision. Final analysis however showed the precision to be $\pm .003\mu$ which in terms of percentage at a coefficient of friction of 0.4 equals $\pm 3/4 \%$. This is of course far better than was expected and it is therefore interesting to consider why such precision was obtainable.

In the first instance the measurement of dry friction has always been considered to be subject to large errors, whether in academic work or say

metal to metal friction or in practical engineering work on dry bearings, machines slides etc., or in dry brake lining testing.

When, in the past therefore, dynamometer results showed variability, it was considered acceptable, on the grounds that considerable scatter was only to be expected in work on friction. It was also accepted that friction materials could not be made to close limits of behaviour, particularly as they consist of a number of naturally occurring raw materials, and this again was regarded as adequate justification for poor repeatability. Finally, it was known that particularly under repetitive testing conditions, unstable surface films could be built up which due to their instability would introduce further scatter.

Because of these 'known' sources of variation it was taken in this work as axiomatic that the dynamometer results should be completely beyond reproach, and that repetitive test conditions should be avoided and replaced by repeatable, but continuously varying programmes. Hence the emphasis on retrospective cross checking.

Having gained complete confidence in the validity of testing procedures it became clear that 'random' variations between samples of material could be eliminated by attention to detail in raw material selection and production methods. Once more consistent materials became available, coupled with enhanced confidence in test procedure it became more reasonable to attribute residual variation to other sources, however unreasonable they appeared, such as variations within and between cast iron discs. Having identified and allowed for two major sources of variation by exercising control by selection of discs and friction material, the further elimination of sources of error then becomes self propagating in that the removal of each source of error gives better precision to enable progressively smaller errors to be identified and eliminated.

The final scatter shown in Figs. 47 and 48 can still be improved by multiple regression analysis on rate of change of temperature, effects of speed and energy dissipation rates etc. and this leads to speculation as to

why such precision can be obtained in the measurement of friction.

In many friction experiments the results obtained depend for their consistency on the existence of films between the rubbing surfaces of either oxide, contamination, or lubrication. When these break down, catastrophic wear occurs with a large change in the frictional forces. The truth of this statement is obvious in 'lubricated' friction, but is also probably true in say 'pin and ring' tests where oxidation of the metal takes place at the same time as the oxide film is being worn away. In many cases welding can take place between the two rubbing surfaces but its onset is critically dependent on surface contamination.

Brake lining materials are designed to avoid welding, and are used under conditions where continuous replenishment of the surface by substrate can occur without gross damage to the opposing surface. Thus the effect of airborne contamination is masked by the continuous formation of wear debris without in turn risking welding as would occur between two metal surfaces. The process is of course not fully understood and therefore opinions must be largely speculative, but it seems that the absence of metal to metal welding, and the continuous scrubbing of surfaces by mildly abrasive wear products must contribute to the remarkable consistency of performance shown in Figs. 47 and 48.

Finally, although at first sight continuously varying the test conditions would appear to oppose consistency, it is the authors opinion that such a procedure improves consistency by avoiding the formation of unstable surface films.

15.3. Retrospective view of other dynamometer test facilities

The most important cause of variability in previous dynamometer test facilities is without doubt the failure to control test conditions by temperature. The next important factor is less easy to prove, but could well be the almost exclusive use of repetitive applications under fixed conditions. Had these two features been introduced earlier, the author believes that sufficient confidence would have been inspired in the testing procedure to search

out and find all the remaining sources of variation.

In terms of correlation with vehicles, it has been said many times and reported in Chapter 2 (historical) that the precise conditions pertaining on the vehicle must be simulated on the dynamometer if good correlation is to be obtained. Although this has been said, it has not to the authors knowledge every previously been done.

CHAPTER 16. FUTURE WORK

Future work can conveniently be divided into three parts as follows :-

16.1. Practical

Although rigorous proof has yet to be demonstrated that perfect correlation exists between vehicle and dynamometer results, experience has shown that no conflict exists between the two, which cannot logically be attributed to variability on the vehicle side. For this reason it is felt that the expense of improving vehicle tests to a level at which the validity of dynamometer results could be tested is unwarranted. That is not to say that some improvement would not be advantageous, and work will continue in this direction.

Again work could be continued towards converting dynamometers to double, or four brake machines in order to enable vehicle results to be predicted more accurately. This however will not be undertaken except in special cases for the following reason. The material formulators task is to produce better friction materials, and this can best be done by testing materials individually under controlled conditions. Provided that the formulator can predict the results he will get on a vehicle from dynamometer tests, the dynamometer is satisfactory for the purpose for which it was designed and the experience over 2,500 tests shows this to be the case within the limitations of single vehicle tests.

It is the present view that further work should be directed towards improving the ability to predict the effects of known changes in single brakes on the performance of the whole vehicle system by further study of the dynamics of vehicle braking.

16.2. Academic research

There is great scope for further investigation of the causes of residual variation shown in Figs. 47 and 48, Chapter 14.3. Multiple regression analysis has shown that part of the cause is a real effect of rate and direction of change in temperature, and three dimensional graphs have

shown that further definition can be obtained if temperature changes during a single brake application are separated from bulk temperature at the beginning of applications, by plotting μ against the two temperatures θ_1 and θ_2 simultaneously. Further effects would be expected by separating the effects of speed or instantaneous rate of energy dissipation by further multiple regression analysis, but preliminary investigation suggests that these are small.

It is the authors belief that the precision and reliability obtained in this section of the work provides great scope for investigation into the mechanism of friction and wear of resin/asbestos composites and that such investigations might even throw light on friction and wear generally.

16.3. Miscellaneous

The brakes divisions of three large motor manufacturers in the U.K. have all had problems of braking which could not be explained by conventional testing but which have been resolved by the use of programmed machines employing this technique of testing. As further problems emerge minor modifications will be required including specific cases of double brake testing, further investigations of brake noise, investigations into brake judder, and a continuation of the work on brake rotors to include the causes of thermal damage.

Continuation of investigations of the behaviour of vehicle braking systems is facilitated by the ability to separate brake behaviour from behaviour of the vehicle, i.e. suspension characteristics etc. which could not adequately be done while the validity of dynamometers was in doubt.

CHAPTER 17. CONCLUSIONS

- (1) An inertia dynamometer can be used to measure the frictional characteristics of brake linings with great accuracy and reproducibility.
- (2) The wear rate of brake linings under a range of operating conditions can be accurately evaluated on an inertia dynamometer.
- (3) Fade tests can be conducted on a dynamometer giving repeatable and meaningful results.
- (4) Brake noise can be measured on dynamometers which correlates well with that on a road vehicle.
- (5) The coefficient of friction measured on a brake depends not only on the instantaneous speed, pressure and temperature etc., but also on the rate and direction of temperature change.
- (6) The temperature change within a brake application has a different effect on coefficient of friction than temperature change between applications.
- (7) Complex patterns of frictional behaviour during changing operating conditions are not random variations, and can be repeated with great precision.
- (8) All the behaviour of a single brake on a dynamometer can be shown to relate well to the behaviour patterns experienced on a vehicle.
- (9) In the development of friction materials, the study of a single brake on a dynamometer can be used to predict the behaviour of a total brake system and to separate vehicle characteristics from brake characteristics.
- (10) In order to programme a dynamometer satisfactorily it is necessary to use brake application temperature as the control parameter.
- (11) Non-repetitive programming is necessary to achieve meaningful results.
- (12) Facilities for retrospective cross checking of all important parameters is highly 'cost/effective' in work on tribology.

- (13) Cross checking facilities should refer to the whole measuring system rather than the measurement transducer alone.
- (14) Facilities for retrospective cross checking form a useful addition to frequent calibrations.
- (15) Potentiometric instruments such as torque transducers can be arranged in such a way that the presence of sensitivity errors or zero errors can be continuously recorded, whilst eliminating their effects on accuracy.
- (16) The adoption of brake temperature as the primary control parameter enables accelerated testing to be used without adverse effects on the validity of results, thus achieving substantial economy of testing in both time and money.
- (17) The use of an XY plotter for recording results of friction tests enables the results to be plotted automatically in any desired form such as friction/temperature or friction/rate of change of temperature etc., without the need for processing.
- (18) The use of an XY plotter for recording, facilitates the presentation of every brake application made without either losing detail or over complicating the presentation.
- (19) The use of an XY plotter for recording results enables test evaluations to be available immediately on completion of the test, without manual or computer processing, or even to be observed while the test is in progress.
- (20) Programming to a continuously varying sequence of brake applications, results in a situation where it is valuable to record every brake application, because consecutive applications do not tend to equilibrium behaviour.

- (21) The combination of programmed sequences of brake applications, and the recording of all applications made, results in a vastly more comprehensive picture of frictional behaviour than could be achieved by repetitive testing.
- (22) In order to evaluate small losses in thickness accurately it is necessary to use a micrometer which eliminates human error in operation.
- (23) Different cast iron discs and drums show important differences in frictional behaviour even though they may be made to a constant specification.
- (24) Different samples of cast iron also show difference in their wear rates and that of the material against which they are run.
- (25) A given cast iron disc or drum will show important changes in frictional behaviour with time and running, long after conventional bedding has been completed.
- (26) The changes which occur in cast iron behaviour are not associated with operating temperatures which approach the transition temperature in bulk.
- (27) Changes in cast iron can not be related to observable changes in the metallography of micro sections.

APPENDIX 1

Three-factor analysis of variance on each of
two material groups with replication

Friction level		Group 1						Group 2					
		A1		A2		A3		A1		A2		A3	
C1	B1	.38	.41	.34	.53	.36	.38	.39	.48	.46	.50	.33	.38
	B2	.42	.50	.37	.39	.33	.33	.41	.50	.33	.36	.38	.49
	B3	.37	.43	.35	.36	.39	.39	.34	.35	.37	.40	.43	.45
C2	B1	.34	.48	.29	.35	.37	.40	.35	.35	.29	.31	.38	.40
	B2	.35	.40	.36	.45	.38	.39	.36	.40	.39	.41	.36	.38
	B3	.38	.44	.40	.40	.33	.34	.42	.51	.37	.39	.35	.38
C3	B1	.42	.46	.36	.40	.27	.34	.42	.43	.33	.34	.42	.43
	B2	.35	.42	.33	.39	.38	.40	.34	.34	.34	.36	.41	.42
	B3	.35	.36	.38	.45	.39	.41	.38	.43	.41	.43	.35	.36

Source	Degrees of freedom	Group 1	Group 2
		Mean Squares	Mean Squares
A	2	.00643	.00436
B	2	.00005	.00037
C	2	.00057	.00250
AB	4	.00101	.00007
AC	4	.00043	.00064
BC	4	.00063	.00474
ABC	8	.00557	.00870
Residual	27	.00201	.00091

For a difference significant at the 95% level between tests calculate $t_{.95} \sigma \sqrt{\frac{2}{n}}$ where the number of measurements in a test (n) is 15. For group 1 this is $.034\mu$ and for group 2 $.023\mu$.

APPENDIX 2MIXED DUTY SCHEDULEGIRLING TYPE 16 SINGLE FRONT DISC BRAKE

Purpose : Rapid wear and friction assessment during mixed duties.

Brake :

Summary of Schedule

Girling type 16 front disc brake caliper/s.	1. Bedding
9-3/4in x 1/2in discs.	2. Measure, including swell/shrink
Cylinder dia. 2-1/8in.	3. 3 apps. from 62 mph to rest, 30%g, 80°C.
<u>Test Prefix</u> : SG	4. 1 app. from 72 mph to rest, 50%g, 80°C.
<u>Rig Details</u> :	
2-1/2 flywheels	5. 30 apps. from 62 to 30 mph, 30%g, 300°C.
1 sq.in. torque cyl.	6. 1 app. from 72 mph to rest, 70%g, 300°C.
24in torque arm rad.	
0/500 lb.in. ² recorder (torque)	7. 48 apps. from 52 to 30 mph, 30%g, 300°C.
0/1500 or 0/2500 lb.in. ² recorder (pressure)	
21in Sirocco fan.	8. 1 app. from 72 mph to rest, 70%g, 300°C.
	9. 8 apps. from 52 to 30 mph, 30%g, 300°C.
	10. 12 apps. from 52 to 30 mph, 50%g, 400°C.
	11. 8 apps. from 52 to 30 mph, 50%g, 400°C.
	12. 12 apps. from 52 to 30 mph, 30%g, 300°C.
	13. 15 apps. from 62 to 30 mph, 30%g, 250°C.
	14. 1 app. from 72 mph to rest, 50%g, 250°C.

Summary of Schedule - Cont....

15. 3 apps. from 62 mph to rest, 30%g,
250°C.
16. 3 apps. from 62 mph to rest, 30%g,
150°C.
17. Measure, including swell/shrink.

Duration : 4 hours

OPERATING INSTRUCTIONS

- (a) Temperature to be controlled from rubbing thermocouples.
- (b) Cooling air to be set at 30 mph, for the whole of the test.
- (c) Except during bedding, all applications are required to be recorded.
- (d) Except during bedding, note as many initial and final temperatures as time allows.
- (e) Control torque by Unitork throughout.

APPENDIX 3

<u>Application</u>	<u>Light</u>	<u>Medium</u>	<u>Heavy</u>
	1. 800	920	1200 rev/min
	2. 670	760	1000 " "
	3. 540	620	810 " "
	4. 300	340	430 " "
<u>Release</u>	5. 470	550	710 " "
	6. 380	450	580 " "
	7. 230	270	340 " "
	8. 0	0	0 " "

Pressure 1 = 200 psi. Pressure 2 = 300 psi.

Speeds are programmed as follows, with the corresponding line pressures required, alongside :-

<u>Applcn.</u>	<u>T. Speed</u>	<u>B. Speed</u>	<u>Press.</u>	<u>Applcn.</u>	<u>T. Speed</u>	<u>B. Speed</u>	<u>Press.</u>
1	2	8	1	26	2	6	1
2	4	8	1	27	2	5	1
3	2	6	1	28	3	6	1
4	2	7	1	29	1	5	1
5	3	6	1	30	2	6	1
6	2	7	1	31	3	7	1
7	4	8	1	32	1	8	1
8	2	6	1	33	2	6	1
9	2	7	1	34	2	5	1
10	4	8	1	35	2	5	1
11	2	5	1	36	3	7	1
12	2	6	1	37	2	5	1
13	3	8	1	38	2	5	1
14	2	6	1	39	3	8	1
15	2	7	1	40	2	7	1
16	1	6	1	41	2	5	1
17	2	5	1	42	2	6	1
18	2	8	1	43	3	7	1
19	4	8	1	44	2	6	1
20	2	6	1	45	3	6	1
21	1	8	2	46	2	5	1
22	3	6	1	47	3	7	1
23	2	7	1	48	2	7	1
24	2	6	1	49	3	8	1
25	3	6	2	50	2	7	1

The above repeated 3 further times to make up a total of 200 applications.

APPENDIX 4CHART LENGTH

Nomenclature :

A	Piston Area	sq.in.
I	Dynamometer Inertia	lb.ft. ²
c	Chart length	cm
C	Total chart length	cm
n	Total number of applications in series	
P	Brake pressure	lb/sq.in.
R	Effective radius of brake	ft.
t	Time	sec.
t _b	Braking time	sec.
T	Braking torque	lb.ft.
u	Chart speed	cm/sec.
w	Dynamometer speed	rad/sec.
μ	Coefficient of friction	

Suffixes :

- s refers to start of application
 e refers to end of application
 r refers to rth application

$$\text{The brake torque } T = 2\mu APR \text{ lb.ft.} \quad (1)$$

Applying Newton's 2nd law and integrating for the rth application

$$t_{br} = \frac{I}{gT} (w_{sr} - w_{er})$$

$$\text{from which } c_r = \frac{uI}{gT} (w_{sr} - w_{er})$$

Summing over the whole series and substituting T from (1)

$$C = \frac{uI}{2ARg} \sum_{r=1}^n \frac{(w_{sr} - w_{er})}{\mu P}$$

or if μ and P are considered constant

$$\mu = \frac{uI}{2APRg} \sum_{r=1}^n (w_{sr} - w_{er}) \frac{1}{C}$$

Thus, since the total number of applications and the application and

release speeds remain unaltered for a given duty level, μ is inversely proportional to C. Some applications were of course carried out at a higher pressure but these were a small proportion of the total and hence the above equation was a good approximation.

APPENDIX 5

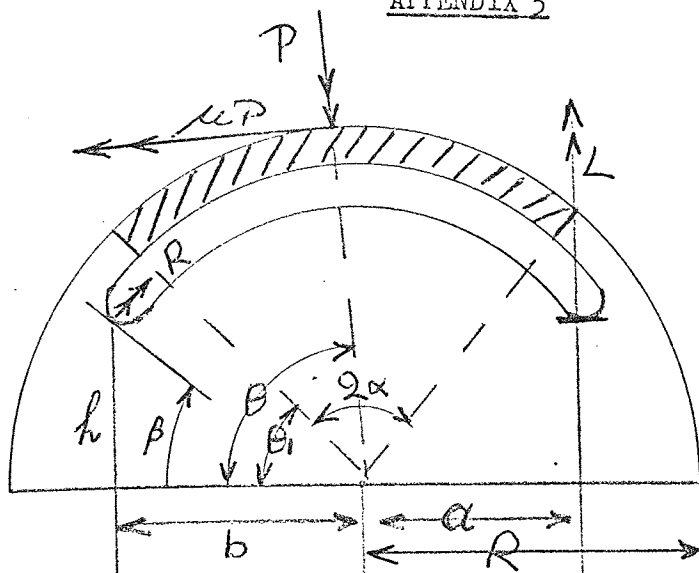

$$\alpha = 56.5^\circ$$

$$\theta = 37^\circ$$

$$\beta = 29^\circ$$

$$a = 5.7\text{in}$$

$$b = 4.9\text{in}$$

$$r = 7.625\text{in}$$

$$R = 3.0\text{in}$$

For FORD D800
Brake

Resolving Vertically

$$L + R \cos \beta - r \int_{\theta_1}^{\theta_1 + 2\alpha} P \sin \theta d\theta - \mu r \int_{\theta_1}^{\theta_1 + 2\alpha} P \cos \theta d\theta = 0$$

Resolving Horizontally

$$R \sin \beta + r \int_{\theta_1}^{\theta_1 + 2\alpha} P \cos \theta d\theta - \mu r \int_{\theta_1}^{\theta_1 + 2\alpha} P \sin \theta d\theta = 0$$

Taking Moments

$$La - Rb \cos \beta - Rh \sin \beta + \mu r^2 \int_{\theta_1}^{\theta_1 + 2\alpha} P d\theta = 0$$

Pressure $P = A \cos \theta + B \sin \theta$

Shoe factor $S = \text{Drag at drum radius per unit shoe tip load}$

$$= \frac{\mu r}{L} \int_{\theta_1}^{\theta_1 + 2\alpha} P d\theta$$

$$T = \text{S.P.A.} \times \frac{r}{12} \text{ lb.ft.} = 7625S.$$

If $\mu = .1$	$S = .257$	$T = 1960$	lb.ft.
.2	.616	4700	" "
.3	1.126	8600	" "
.4	1.877	14400	" "
.5	3.041	23200	" "
.6	4.991	38000	" "
.7	8.719	66600	" "

REFERENCES

1. Bockius and Hunt S.A.E. Journal 30th anniversary 1935 issue.
2. Sisman I.A.E. Journal Dec. 1936
3. Taylor and Holt Journal of Research National Bureau of standards. Vol. 24, May 1940.
4. Kragelskii and Gudchenko Bulletin of Academy of Science USSR. Vol. 25, No.11 1955.
5. Construction and Operation of Brake testing Dynamometers S.A.E. Annual Meeting 1953 Detroit.
6. Carpenter Engineer June 1957
7. Sinclair and Gulick S.A.E. Journal March 1962
8. Sinclair Proceedings of Institute of Mechanical Engineers. 1962 - 3. Vol. 8.
9. Meek S.A.E. Journal, Jan. 9 - 13. 1967, 670070
10. Finchk A.T.Z. Oct. 68. Vol. 70, No. 10.
11. Howard and Winge Automotive Engineering Congress, 1967, 670144.
12. Brake lining quality control test procedure. S.A.E. recommended practice J661A.
13. Anderson, Gratch and Hayes S.A.E. Paper, 670079, Jan. 1967.
14. Wright-Baker Engineering June 1958
15. Hatch and Goddard Proc. Inst. Mech. Eng. 1966 - 7. Vol. 181, Part 2A.
16. Wilson Proc. Inst. Mech. Eng. 1966 - 7. Vol. 181, Part 2A.
17. Muzechuk S.A.E. Chicago, May 15 - 19, 1967.
18. Moore and Watton Proc. Inst. Mech. Eng. Vol. 185. 12/71.
19. Odier Proc. Inst. Mech. Eng. Vol. 186. 7/72.

20. Variable load fatigue testing. M.I.R.A. Report No. 1, 66/14.
21. Bell and Burdekin Proc. 8th M.T.D.R. Conf. Manchester 1967.
22. Newcomb Automobile Engineer. 1960, Vol. 50
P.326.
23. Fazekas Trans. S.A.E. N.Y. 1953, Vol. 61.
P.279.

GENERAL ARRANGEMENT OF FIRST BRAKE DYNAMOMETER (N.P.L.)

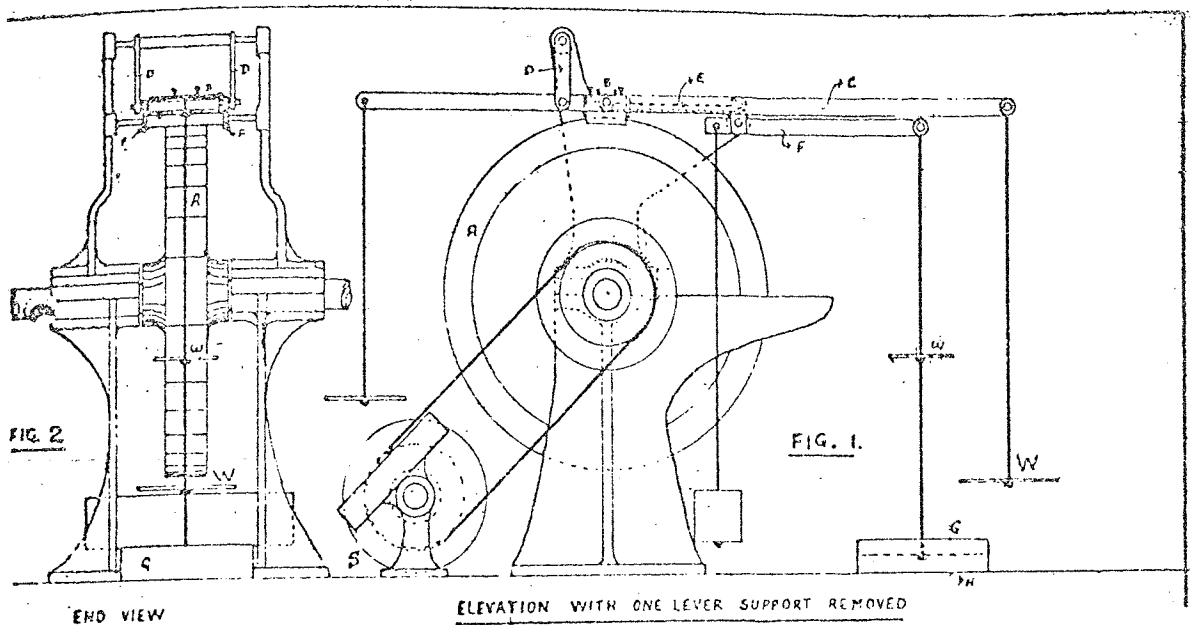

END VIEW

ELEVATION WITH ONE LEVER SUPPORT REMOVED

SCALE $\frac{1}{8}$ FULL SIZE

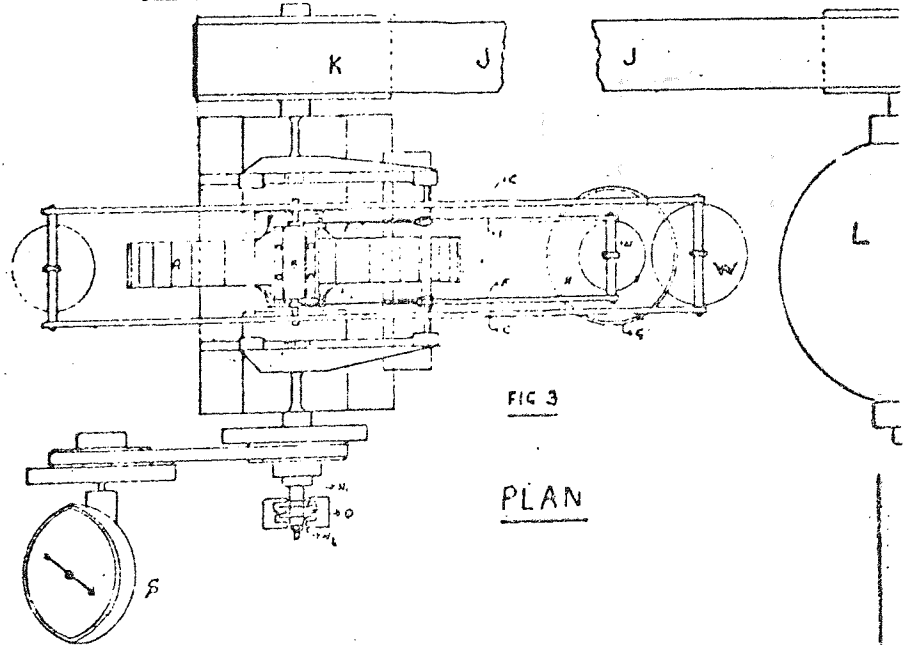

FIG 3

PLAN

A	FRICITION WHEEL.
B	FRICITION BLOCK HOLDER.
C	LOADING LEVER
D	LINKS
E	COUPLING RODS.
F	FRICITION LEVER.
G	ORISK-FOT.
H	DAMPING PLATE.
J	BELT
K	DRIVING PULLEY
L	MOTOR
M	THERMOMETER SLIP RINGS
N	MERCURY TAPMAN
S	THERMOMETER
W	LOAD
X	FRICITION TRACE.

APPARATUS FOR TESTING BRAKE LININGS
FOR THE HERBERT FR300. C. 67

NATIONAL PHYSICAL LABORATORY
Teddington

N.P.L. 105

Fig. 1

TYPICAL TRACE FROM SIX CHANNEL RECORDER

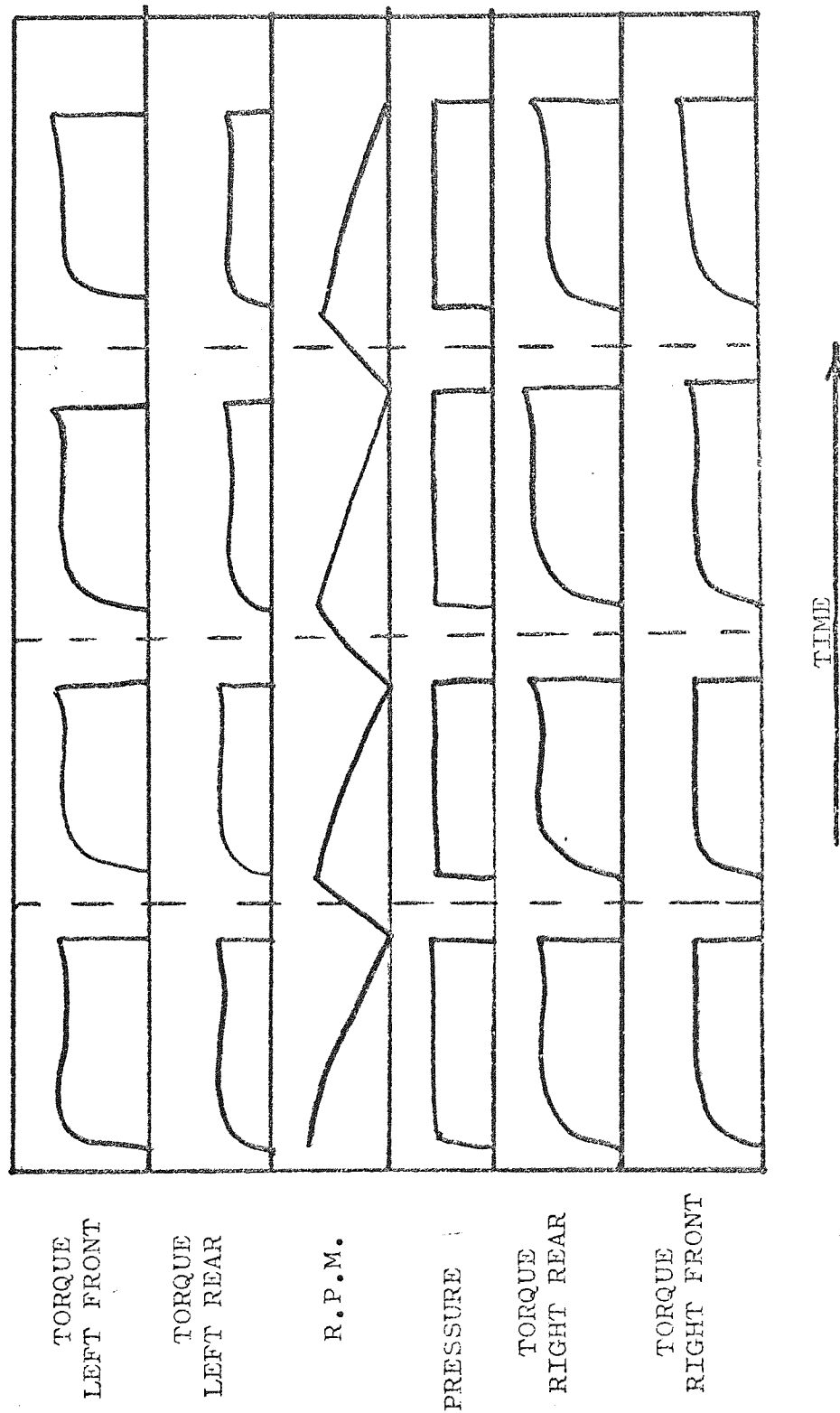
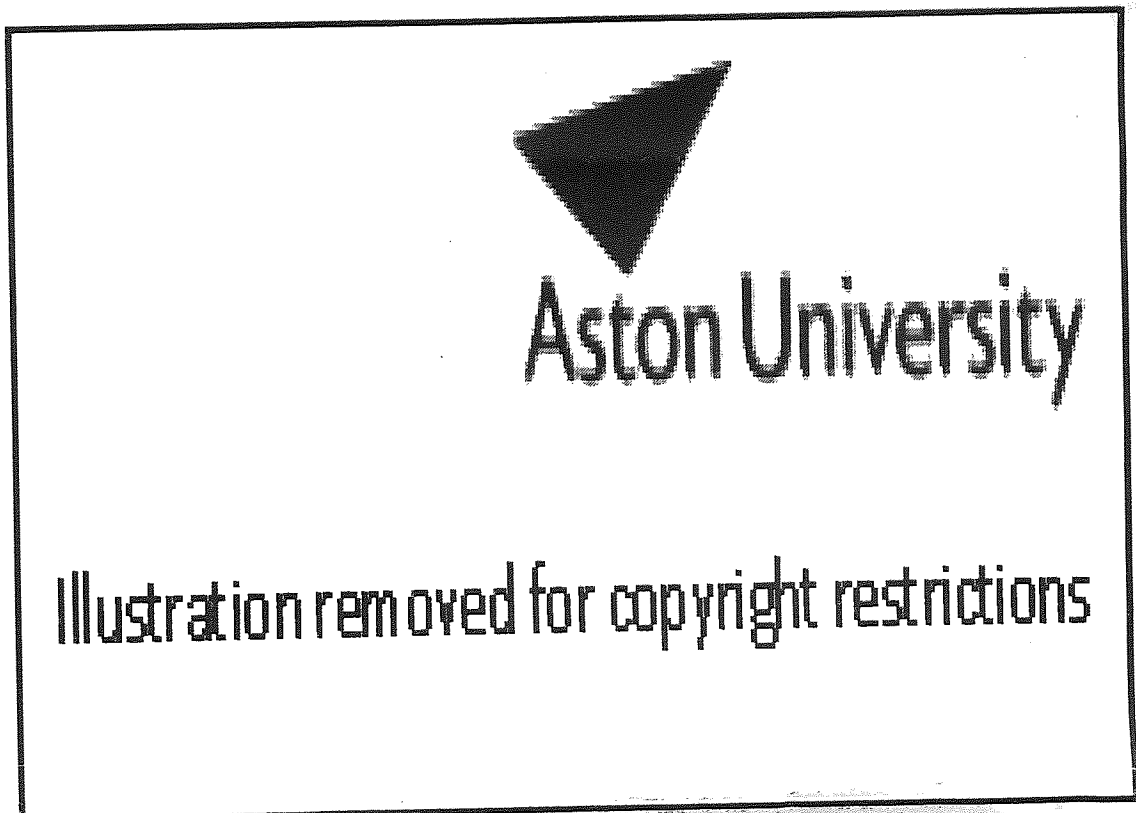
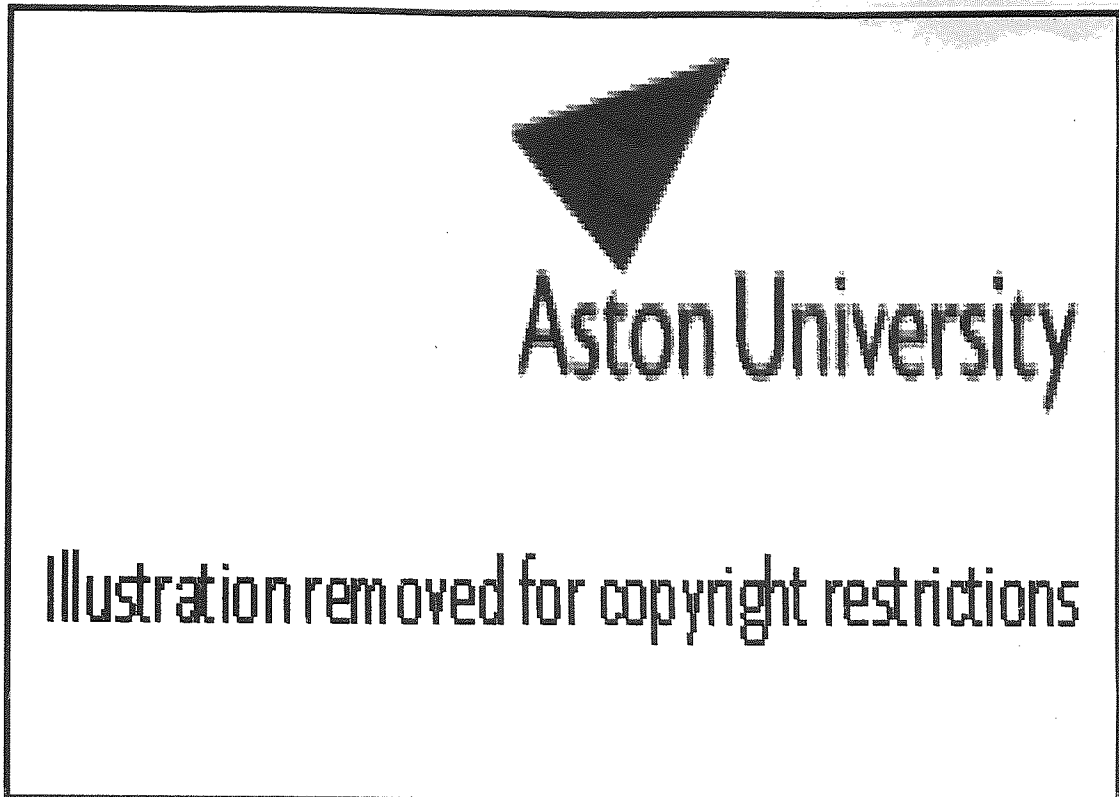

Fig. 2



A cold friction; B friction/temperature; C moderate fade test; D severe fade test; E weight loss; F observations

Fig. 5. Result obtained with a typical test schedule. The shapes of the curves have been chosen to illustrate a large number of the faults that can be identified from the results of this type of test

CORRELATION OF DYNAMOMETER AND VEHICLE RESULTS

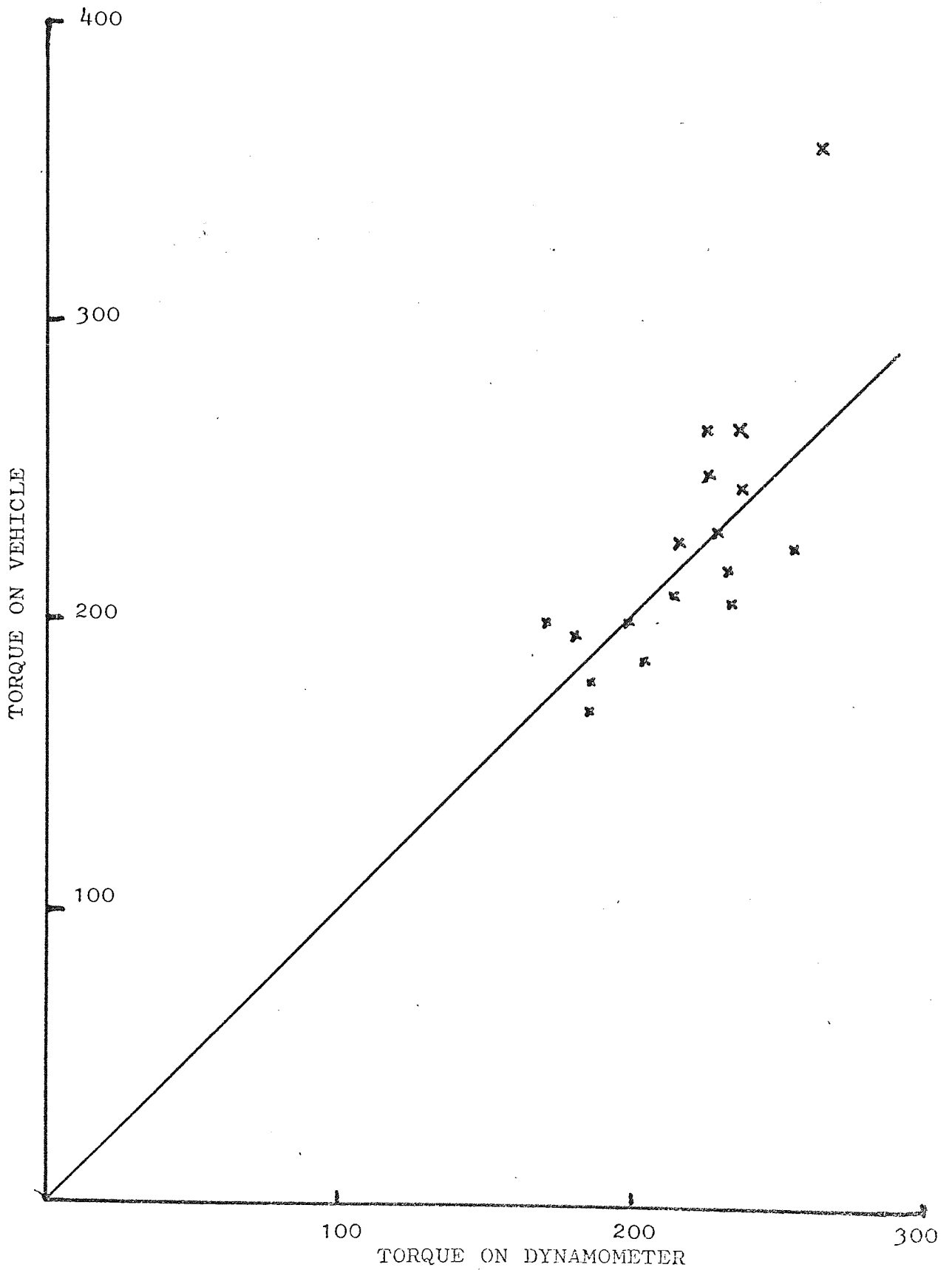

Fig.4

TEMPERATURE/TIME CURVE FOR BRAKE INTERFACE

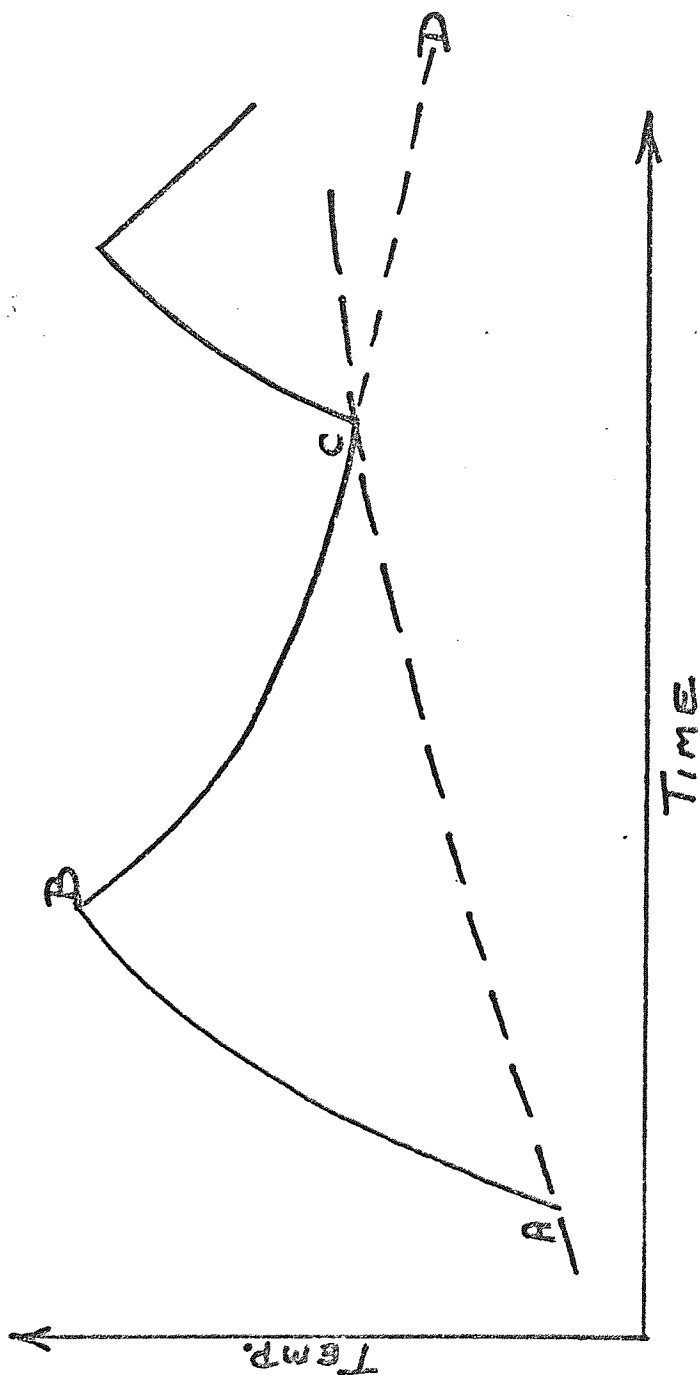

Fig. 5

DOUBLE RUBBING THERMOCOUPLE ASSEMBLY

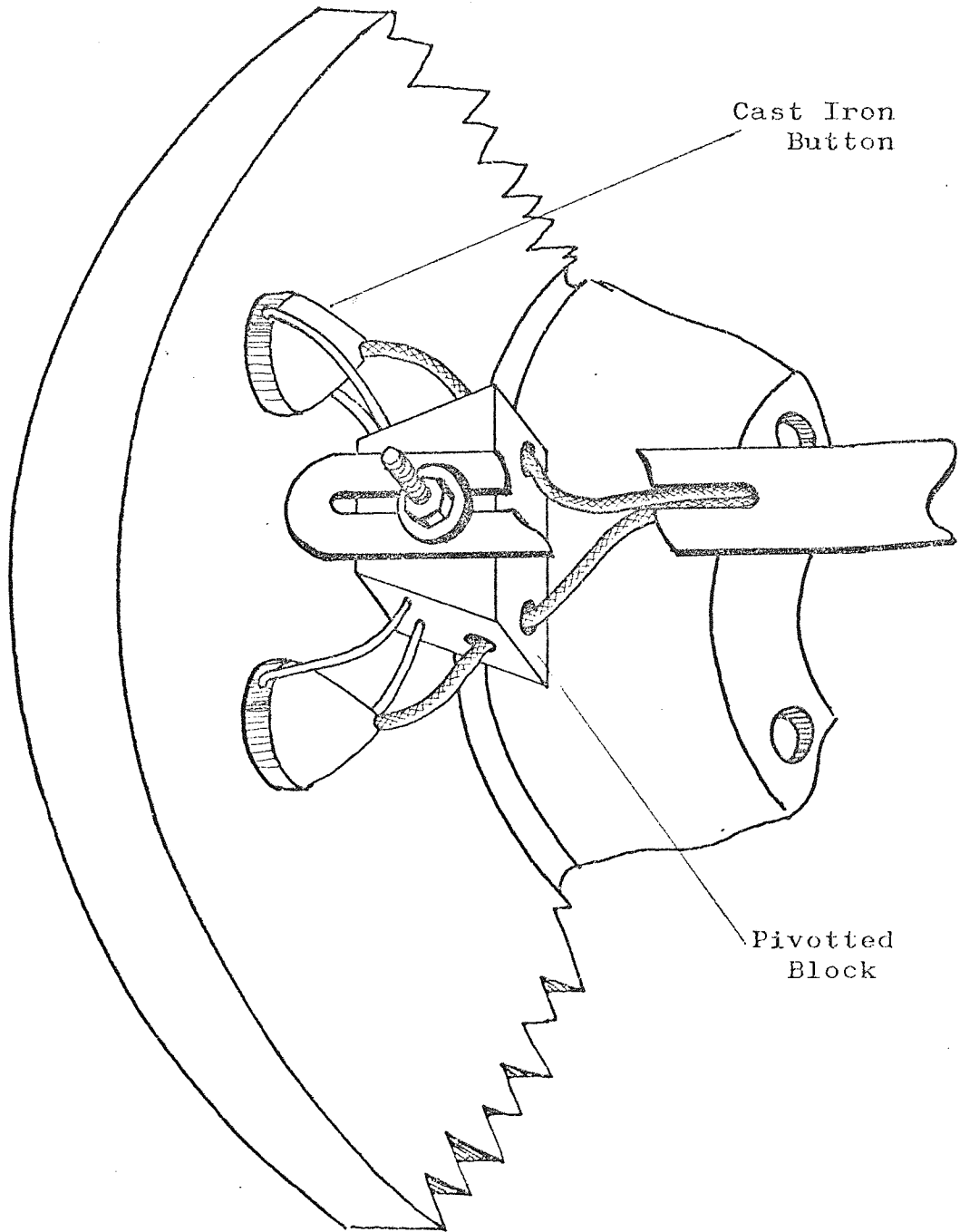

Fig. 6

PROTOTYPE XY PLOTTER/CONTROLLER

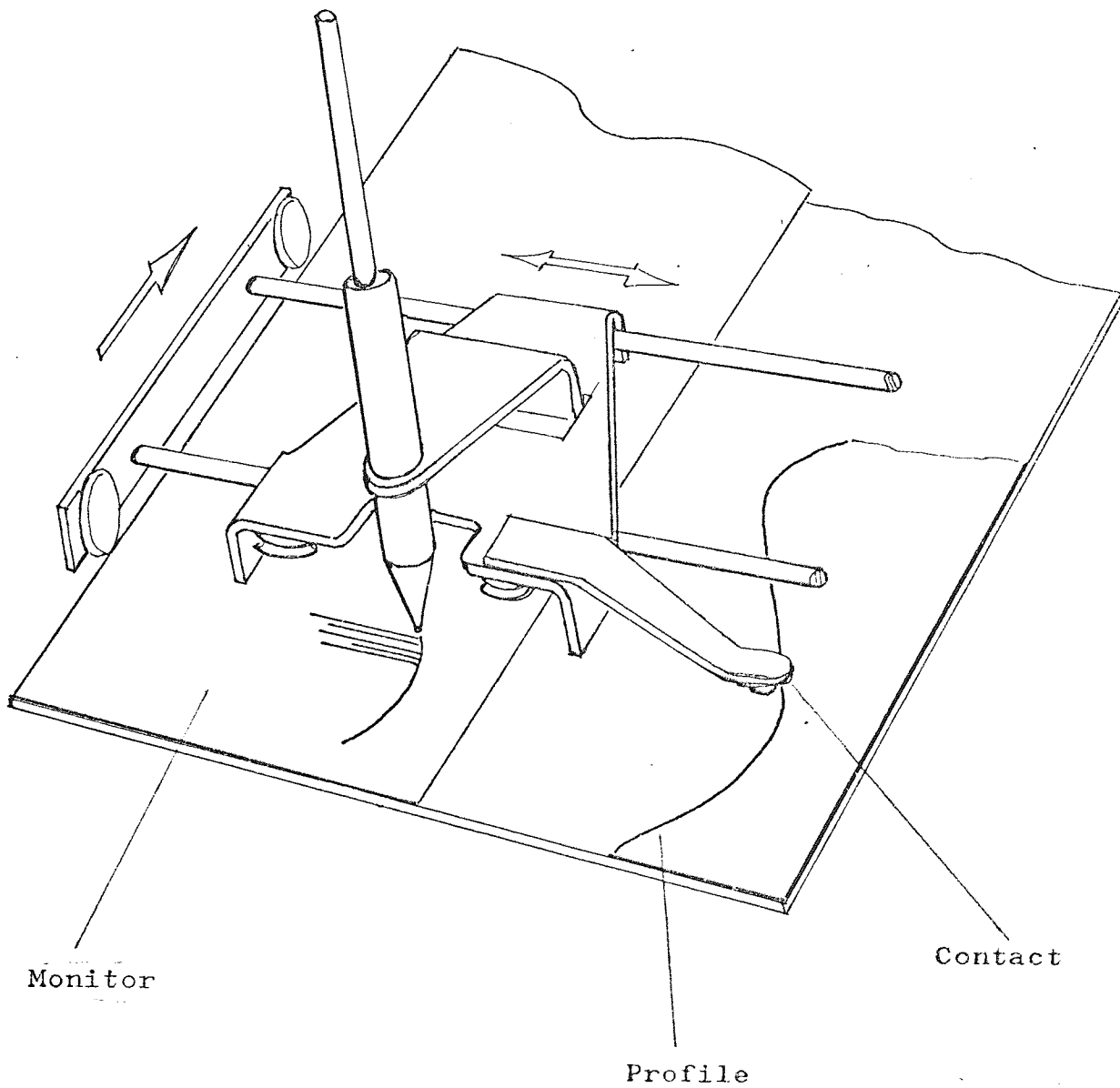

Fig.7

RELATIONSHIP BETWEEN WEAR AND MEAN JOURNEY
TEMPERATURE

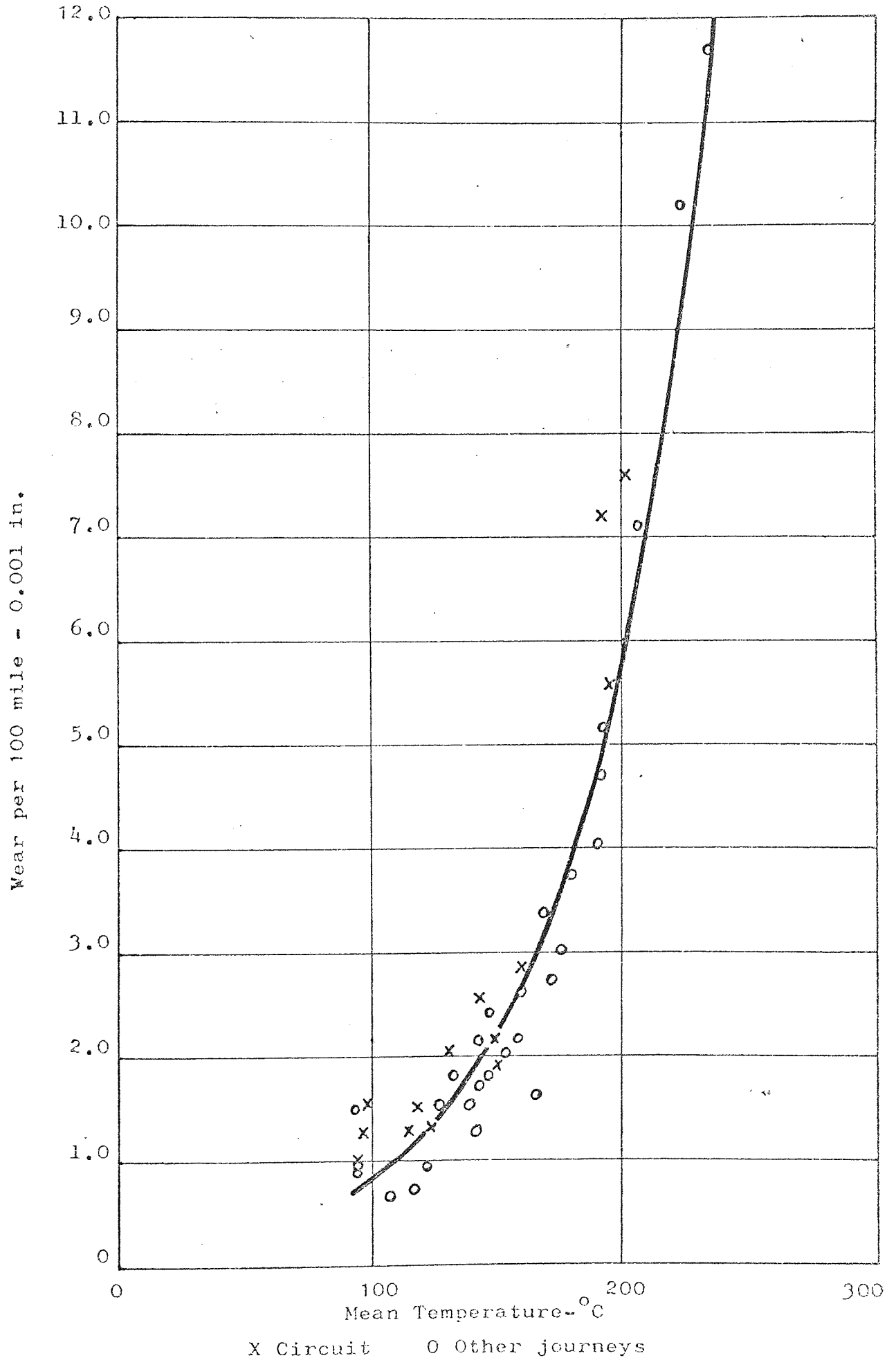
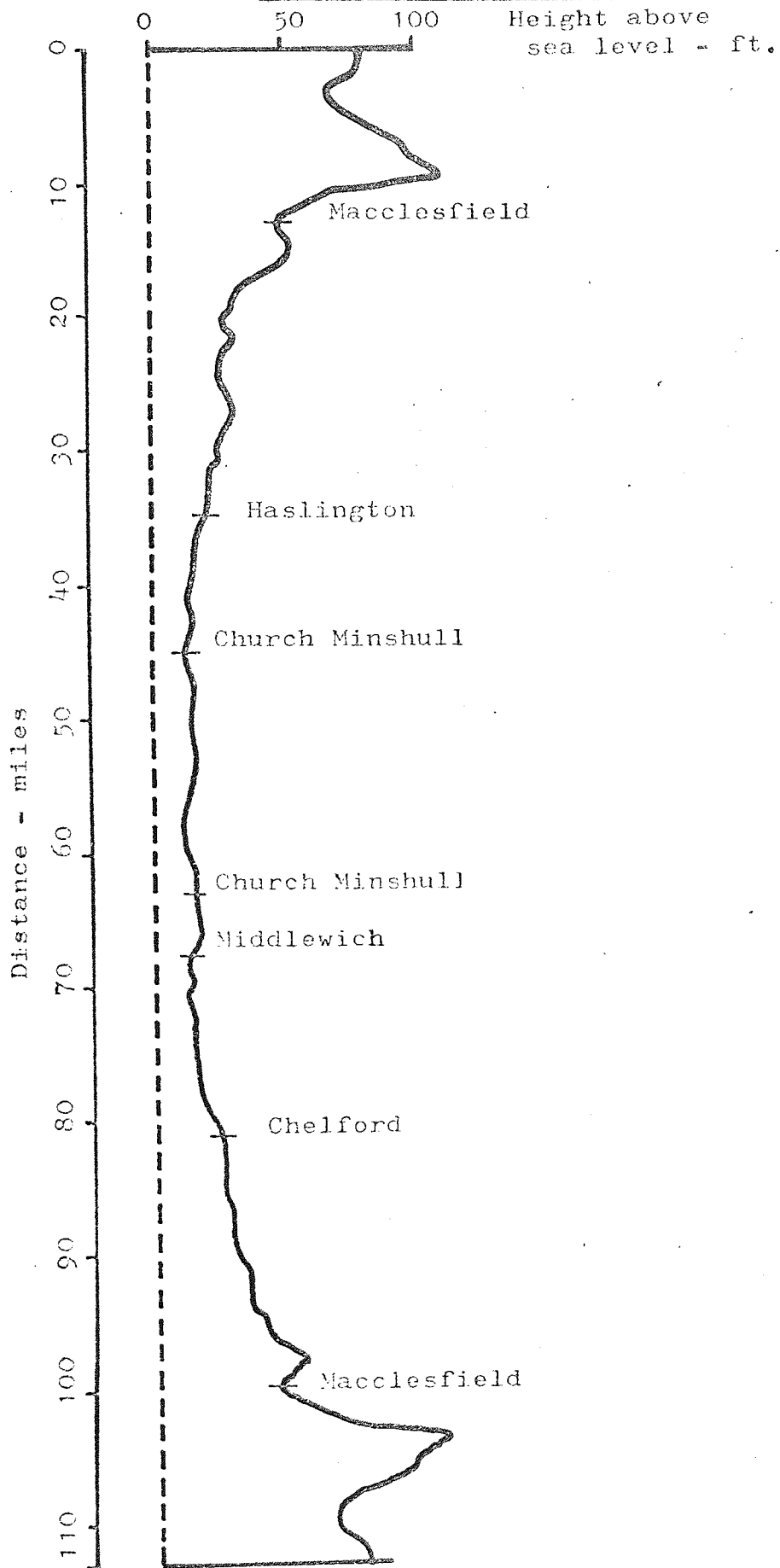

Fig. 8

DIAGRAM OF SIMULATED ROAD CIRCUIT



DISTRIBUTION CURVE OF MEAN CIRCUIT TEMPERATURE

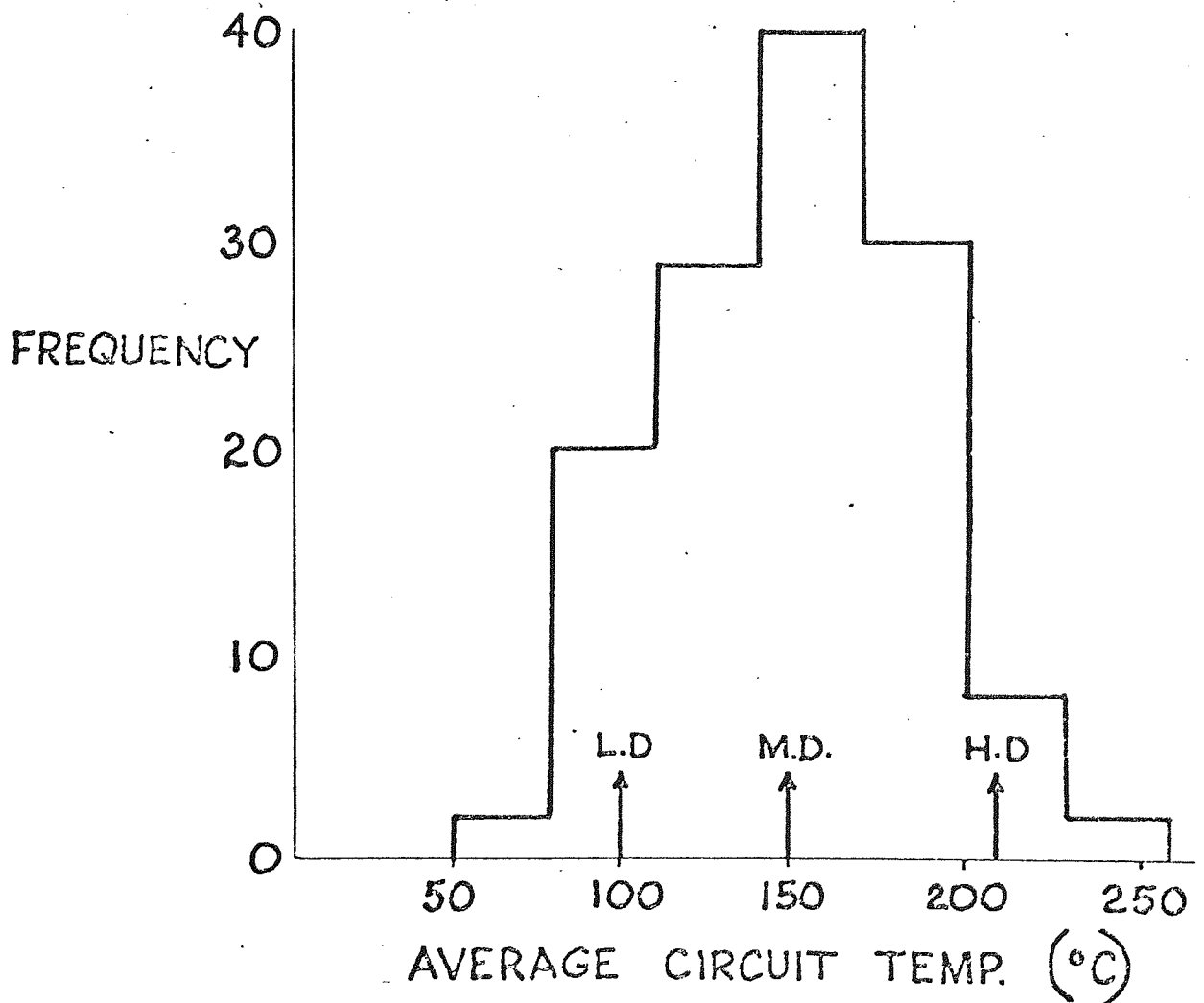

Fig.10

DISTRIBUTION OF TEMPERATURE FOR EACH DUTY LEVEL

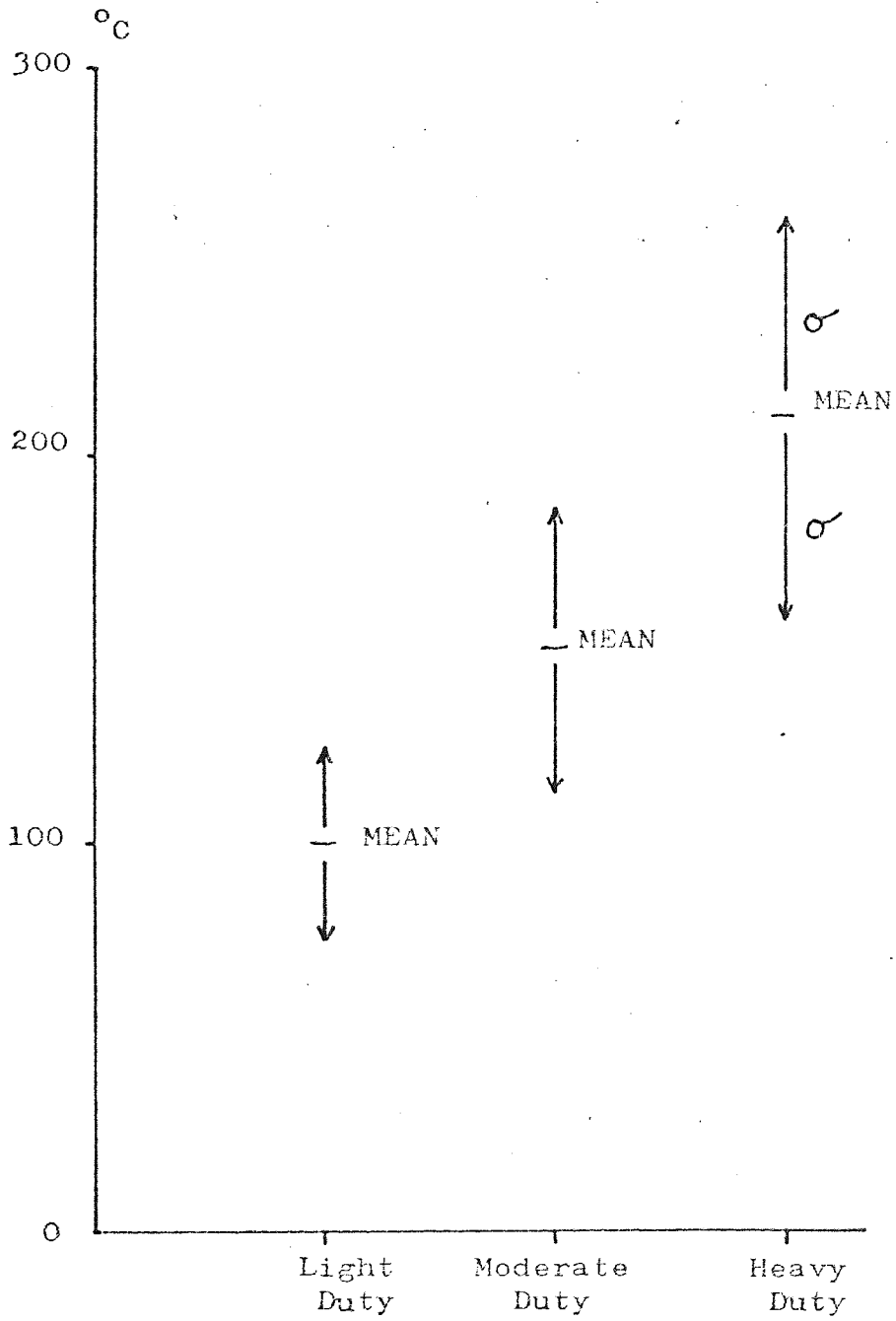

Fig. 11

TEMPERATURE PROFILE FOR EACH DUTY LEVEL

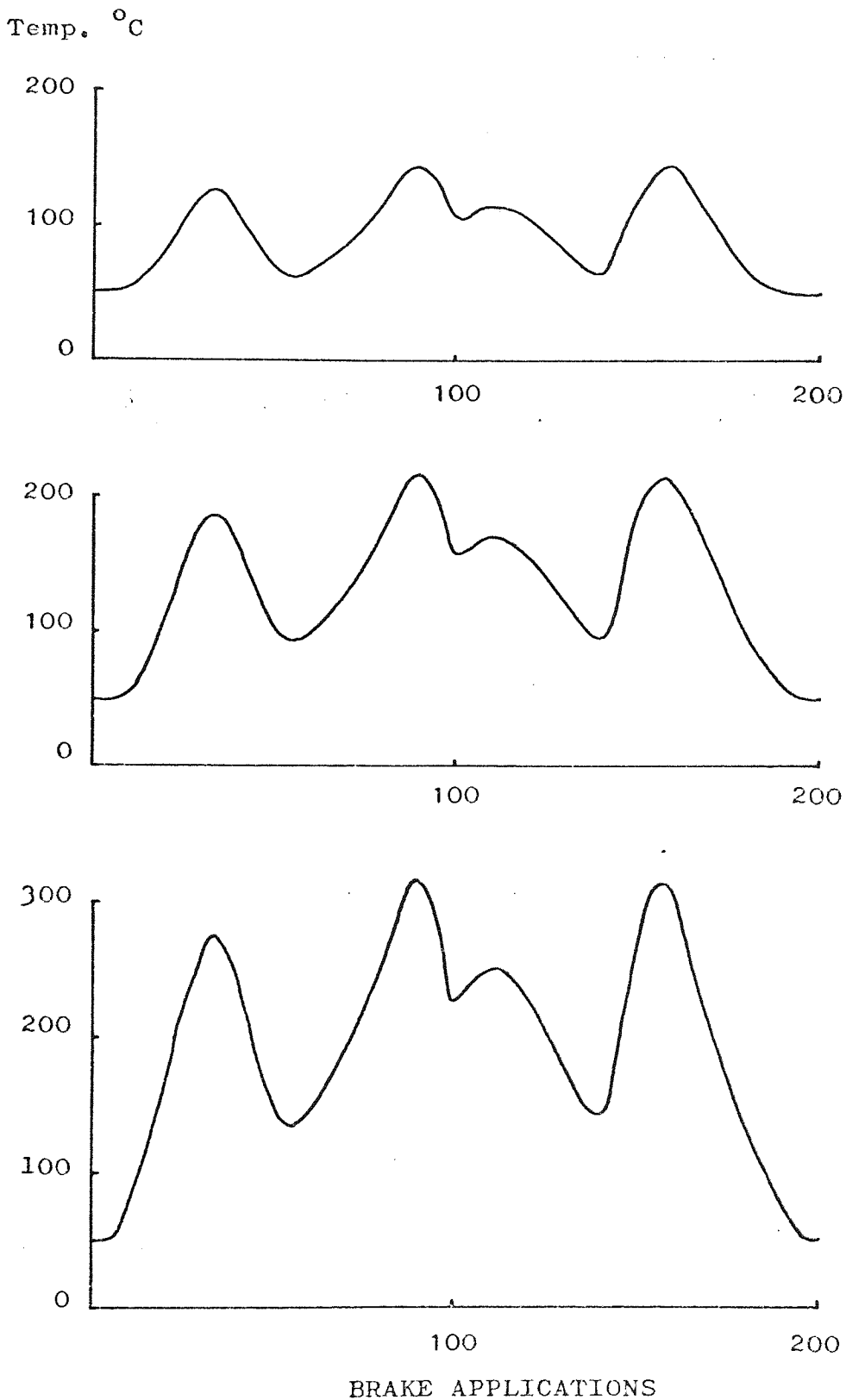

Fig.12

DISTRIBUTION DIAGRAM OF APPLICATION AND
RELEASE SPEEDS

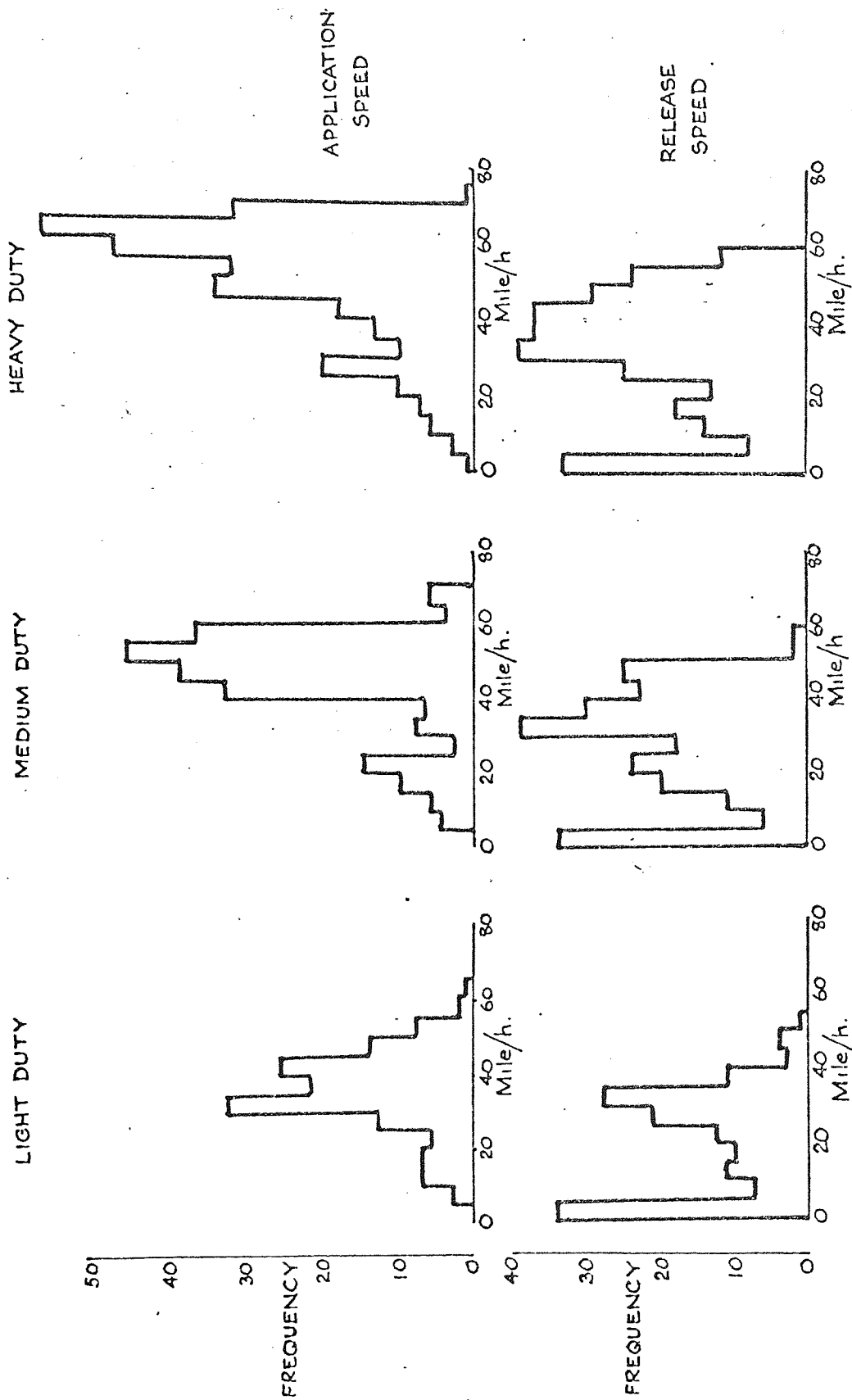
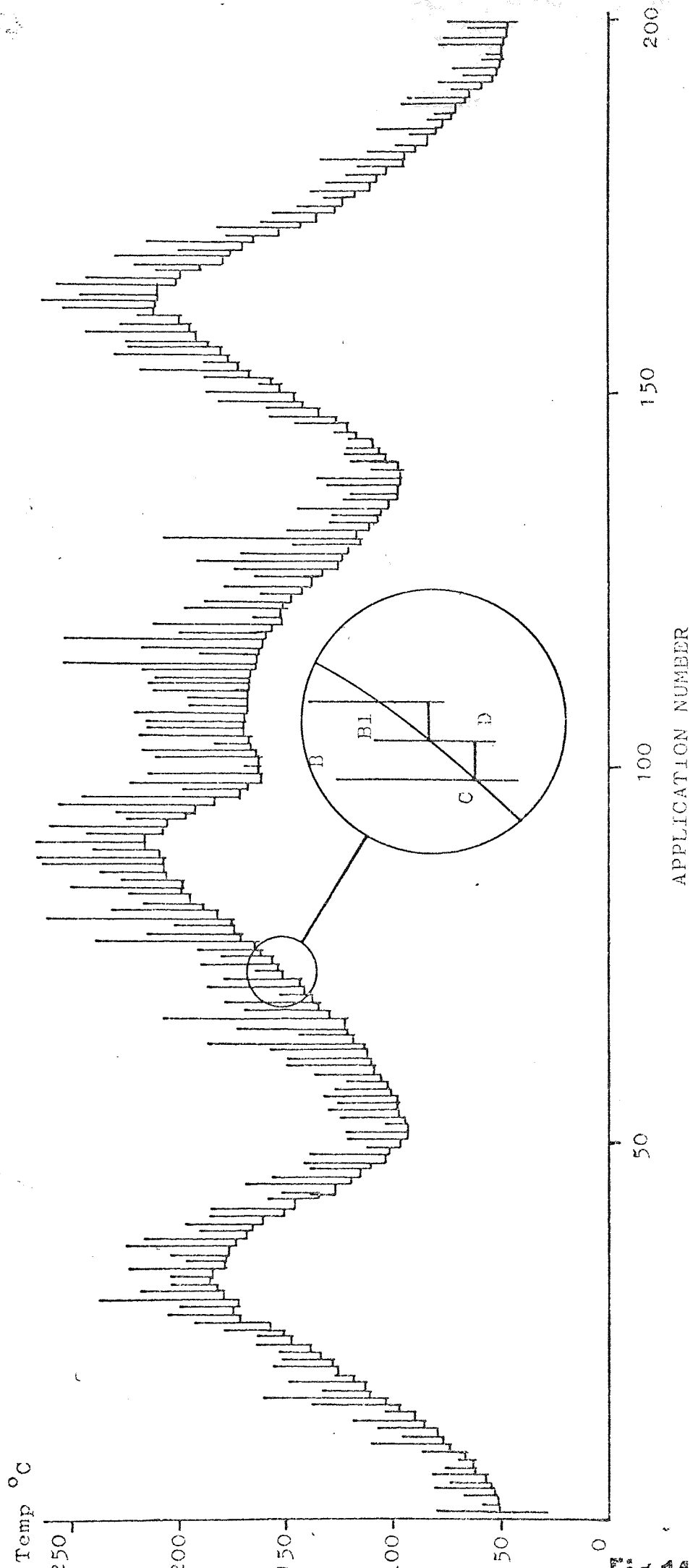

Fig.13

MONITOR OF TEMPERATURE THROUGH 200 APPLICATIONS



FRICTION AND WEAR RESULTS FOR NORMAL AND ACCELERATED COOLING

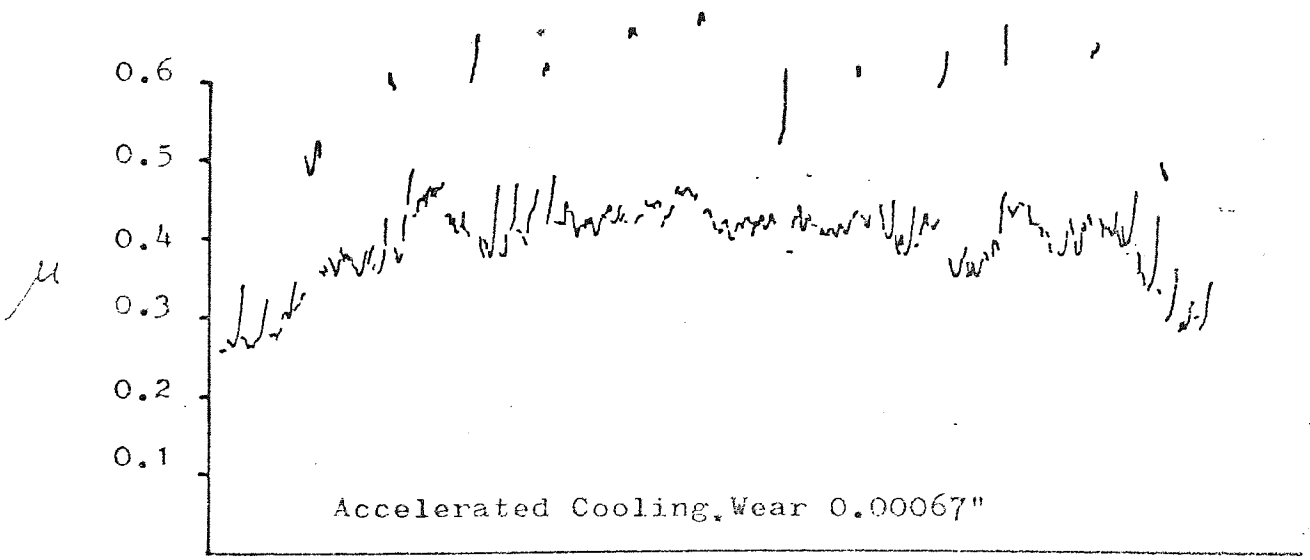
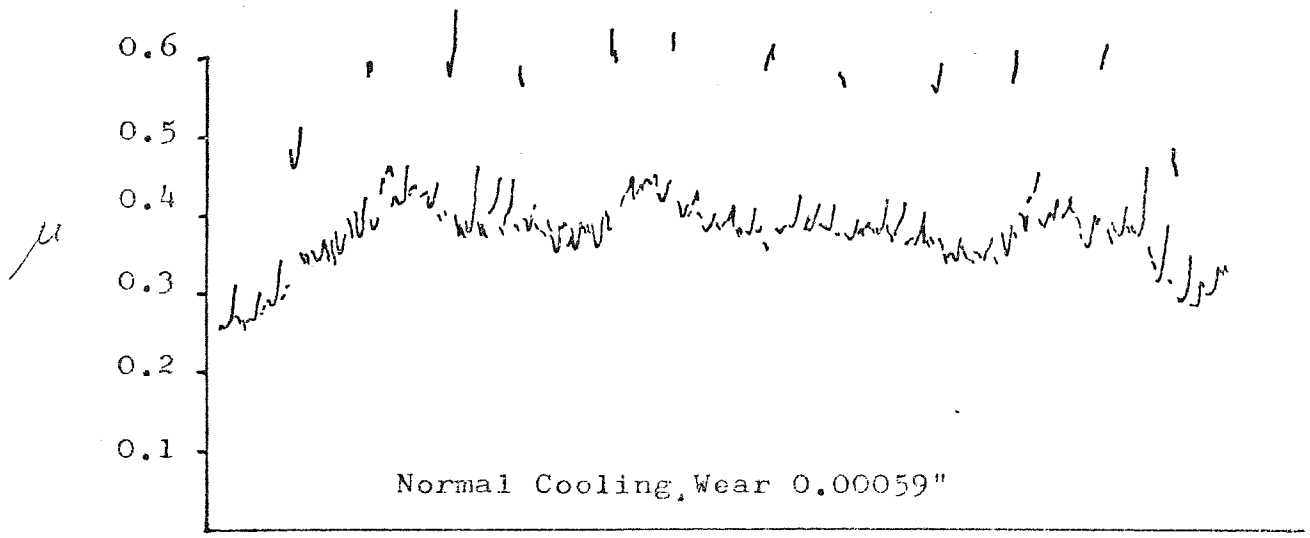
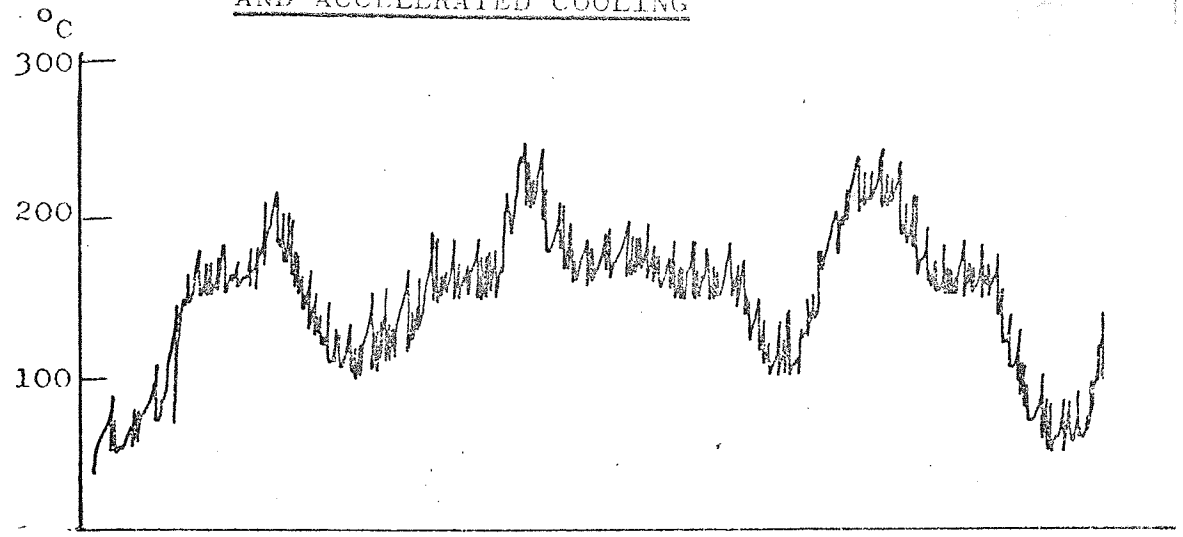

Fig.15

TORQUE AND PRESSURE CURVES FROM TESTS AS
DESCRIBED IN CHAPTER 3.1

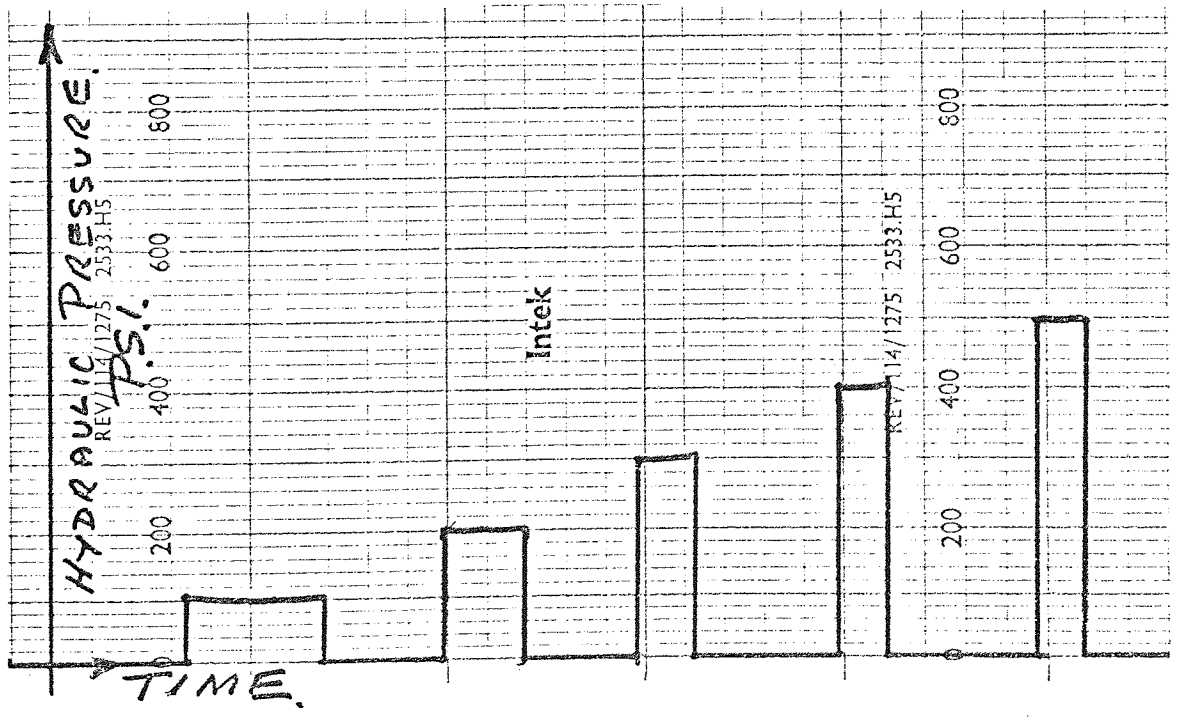
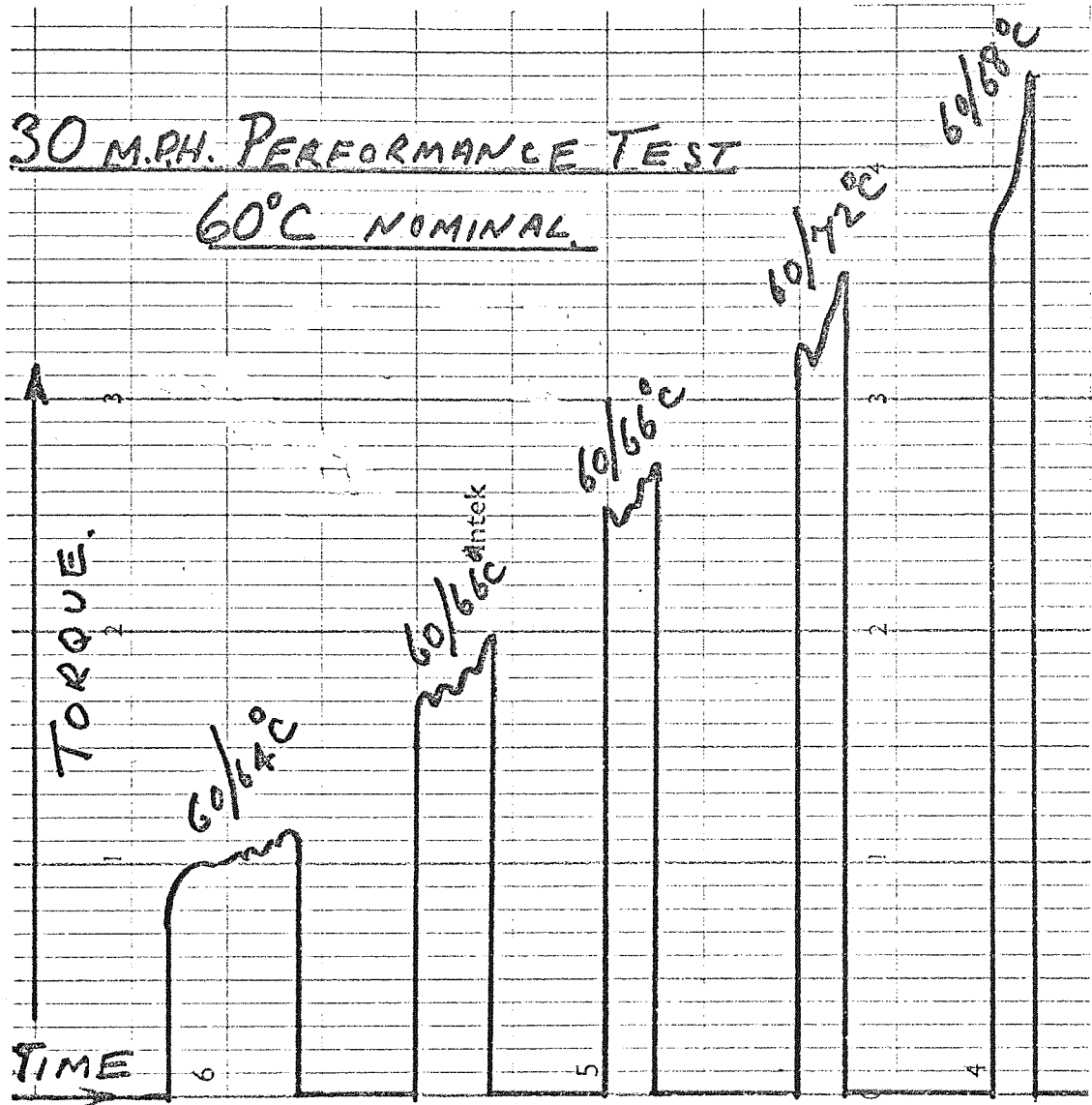

Fig.16

PERFORMANCE TEST PLOTTED FROM THE DATA IN FIG.16

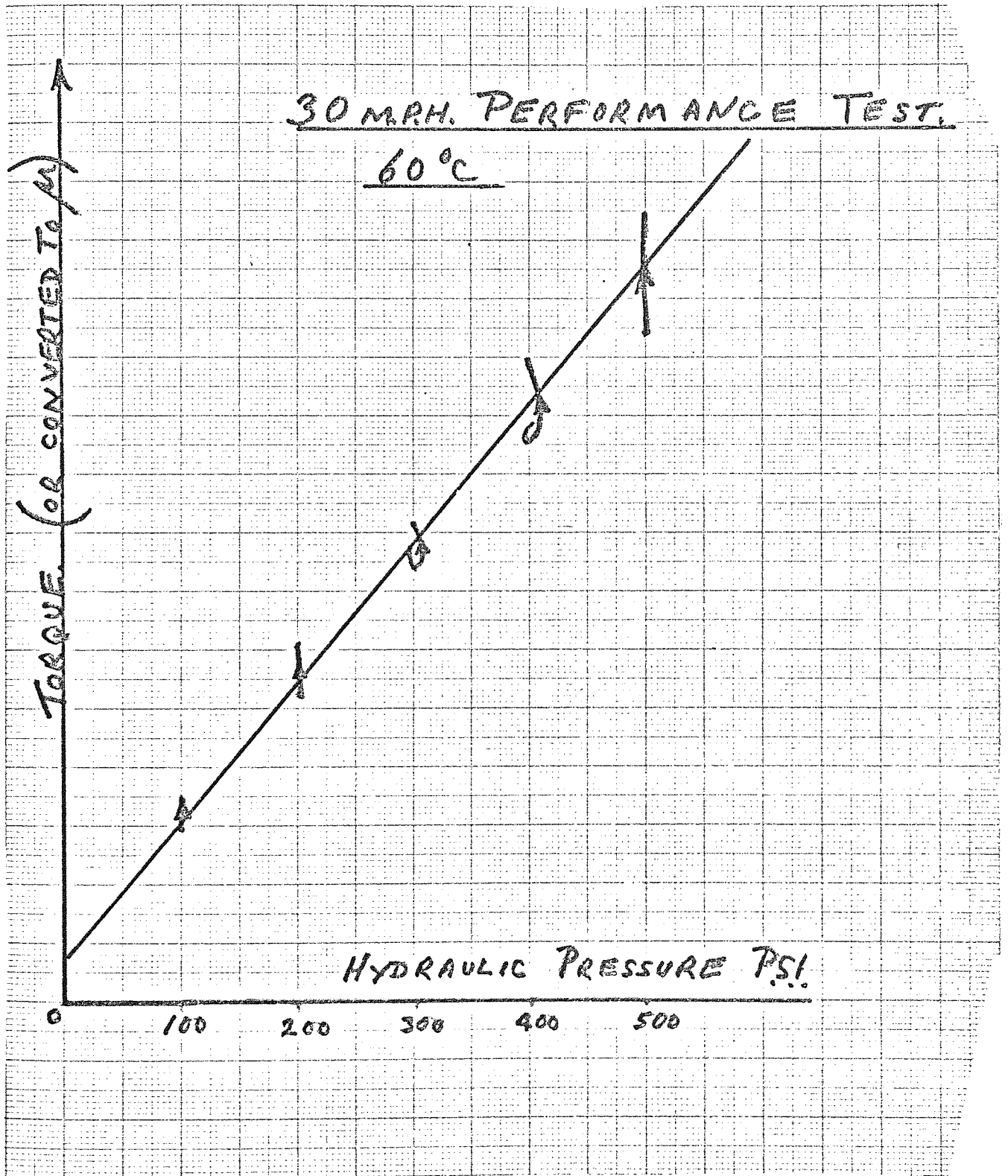

Fig.17

RECORDED μ AND TEMPERATURE PROFILES FOR A MEDIUM DUTY CIRCUIT

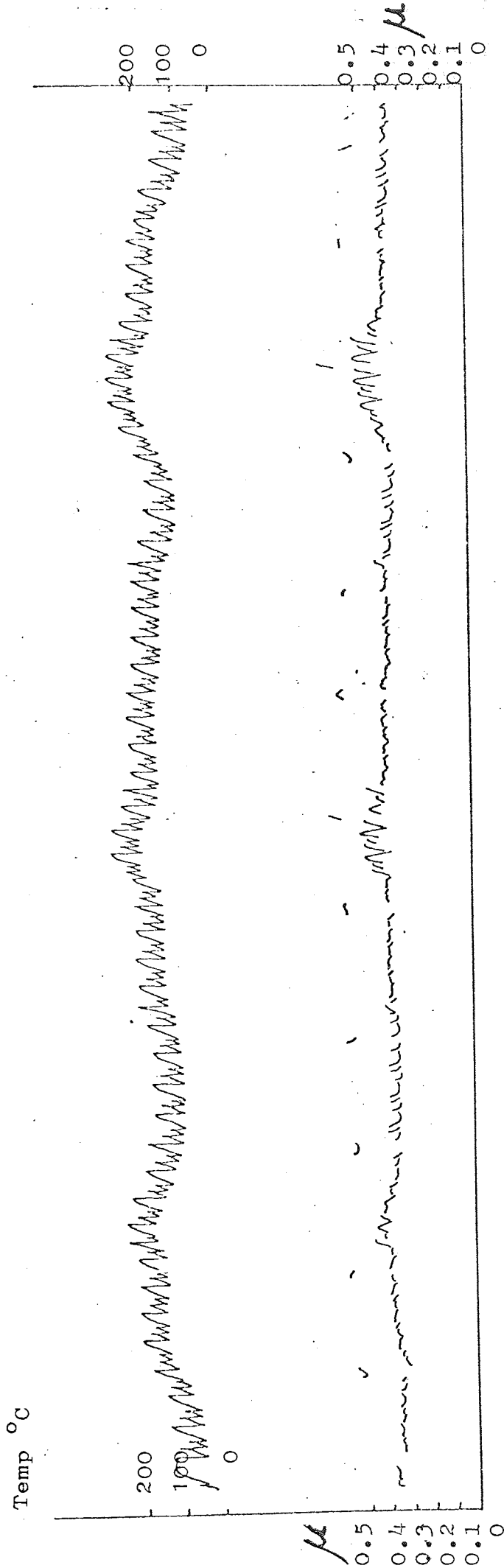

Fig. 18

μ / TIME AND TEMPERATURE TIME CURVES FOR TWO LEVELS OF FRICTION

COMPARISON OF HIGH AND LOW FRICTION MATERIALS

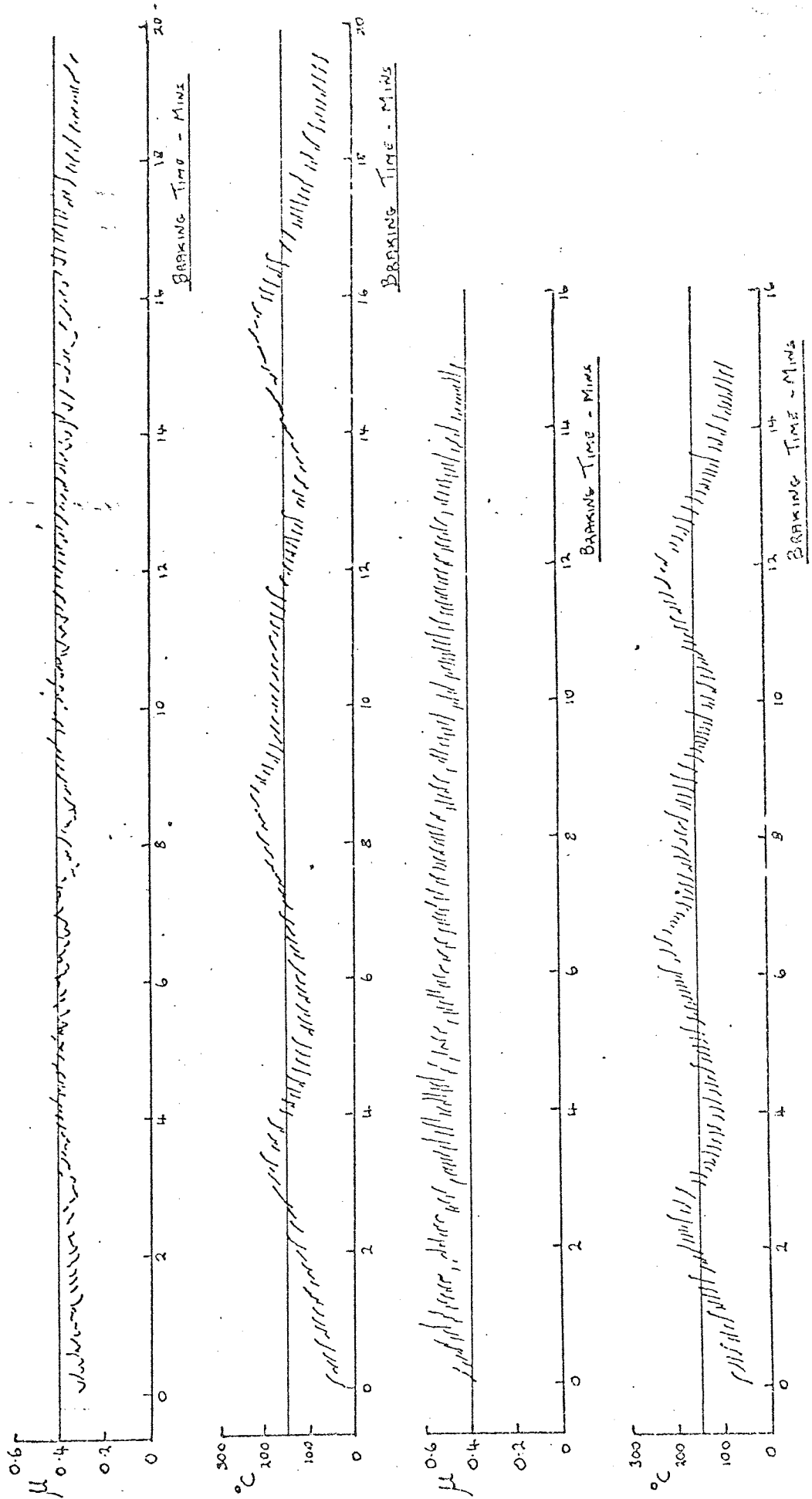
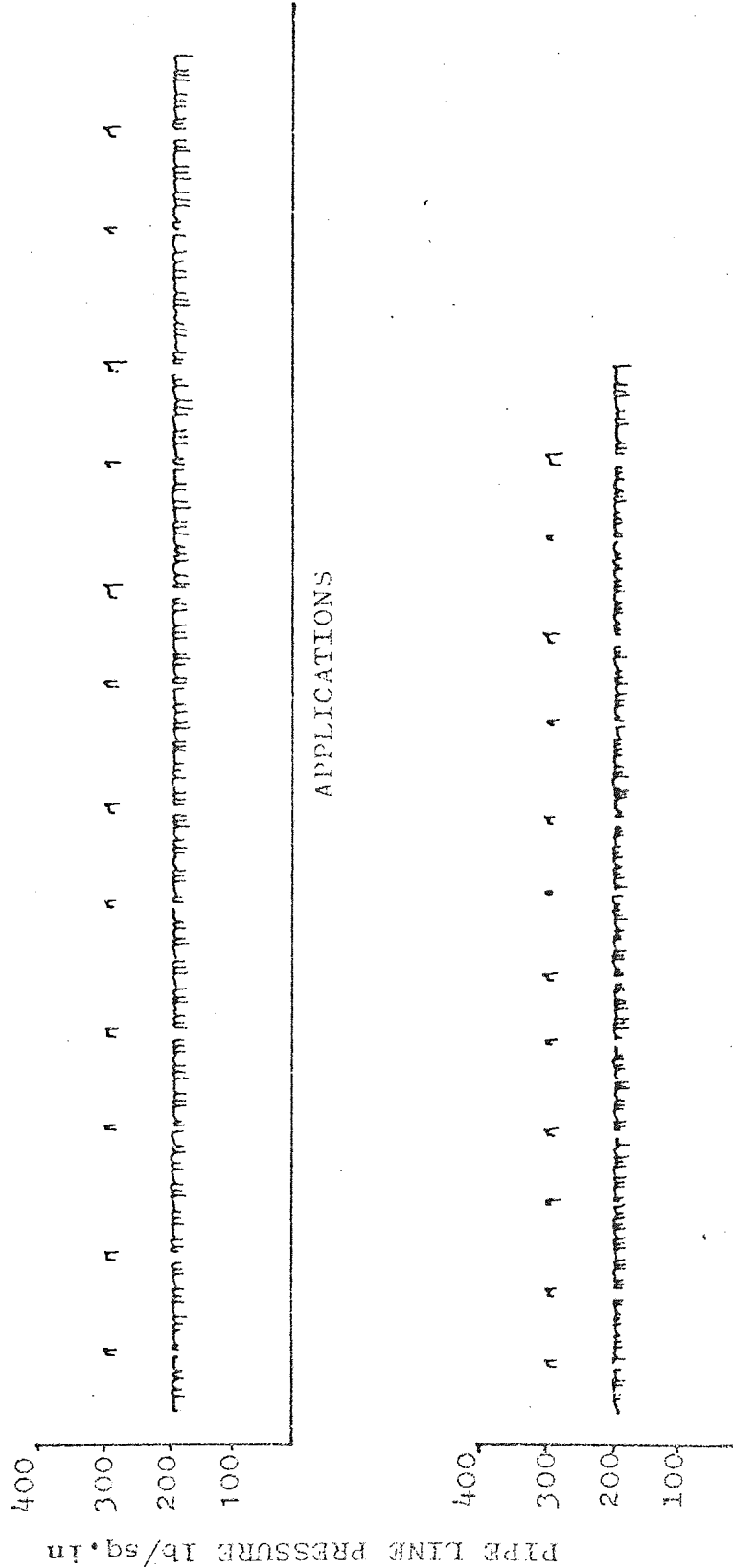

Fig. 19

TWO PRESSURE CHARTS SHOWING DIFFERENT COEFFICIENTS
OF FRICTION



MODIFIED TEMPERATURE/TIME PROFILES WITH CONSTANT TEMPERATURE PERIODS

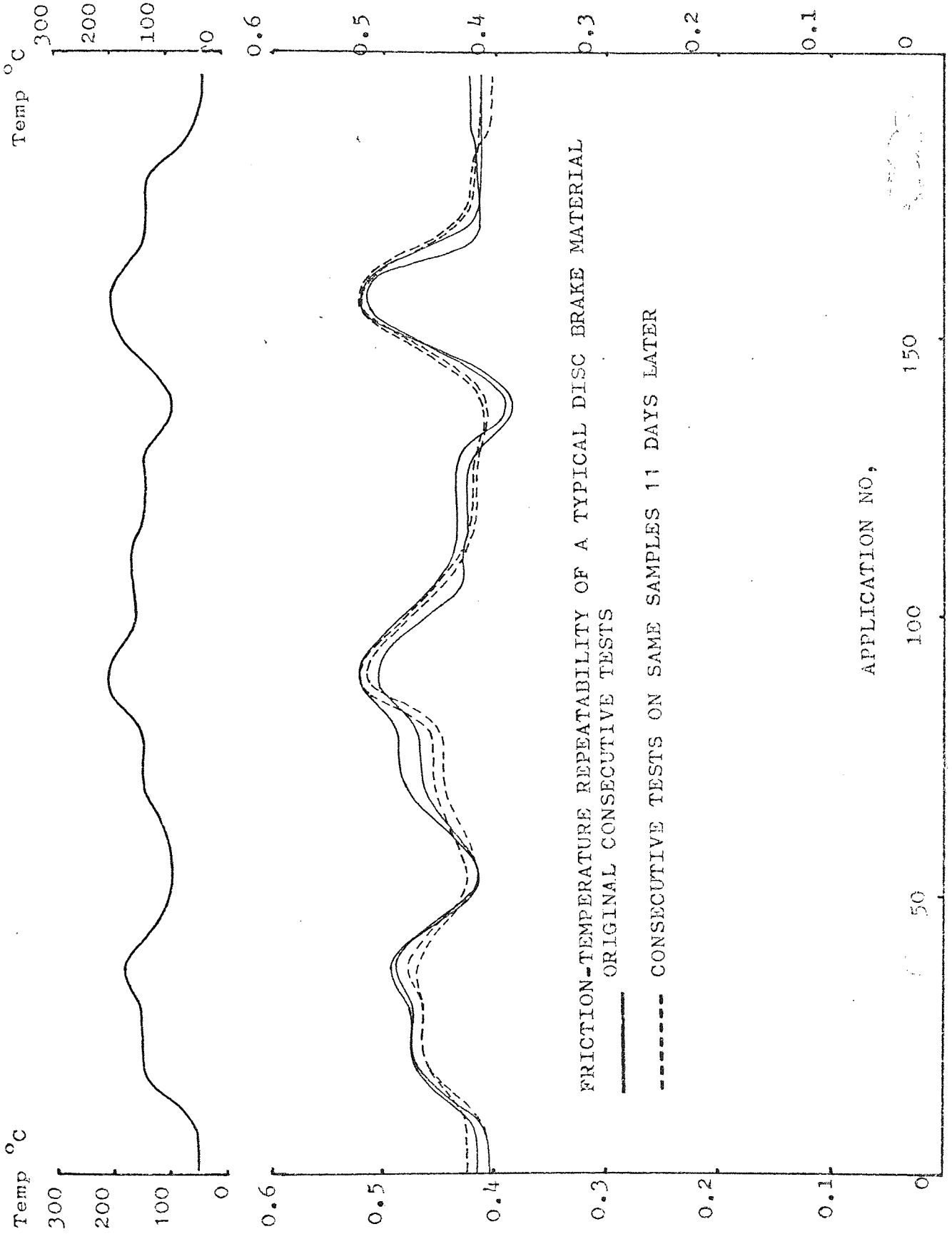

Fig. 21

SINGLE BRAKE APPLICATION AS TORQUE/TIME
AND TORQUE/TEMPERATURE

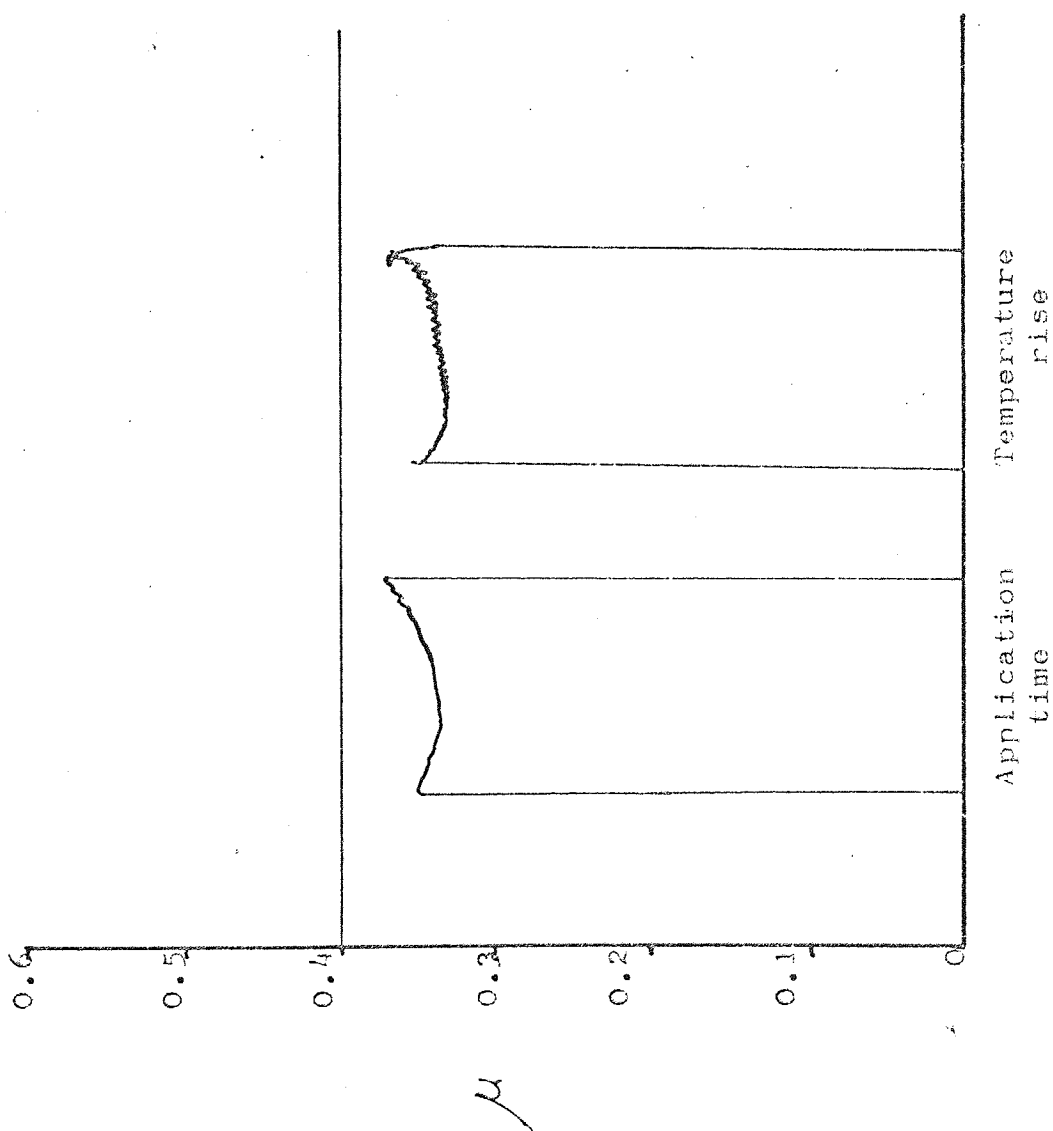

Fig. 22

XY PLOT WITH A FEW BRAKE APPLICATIONS

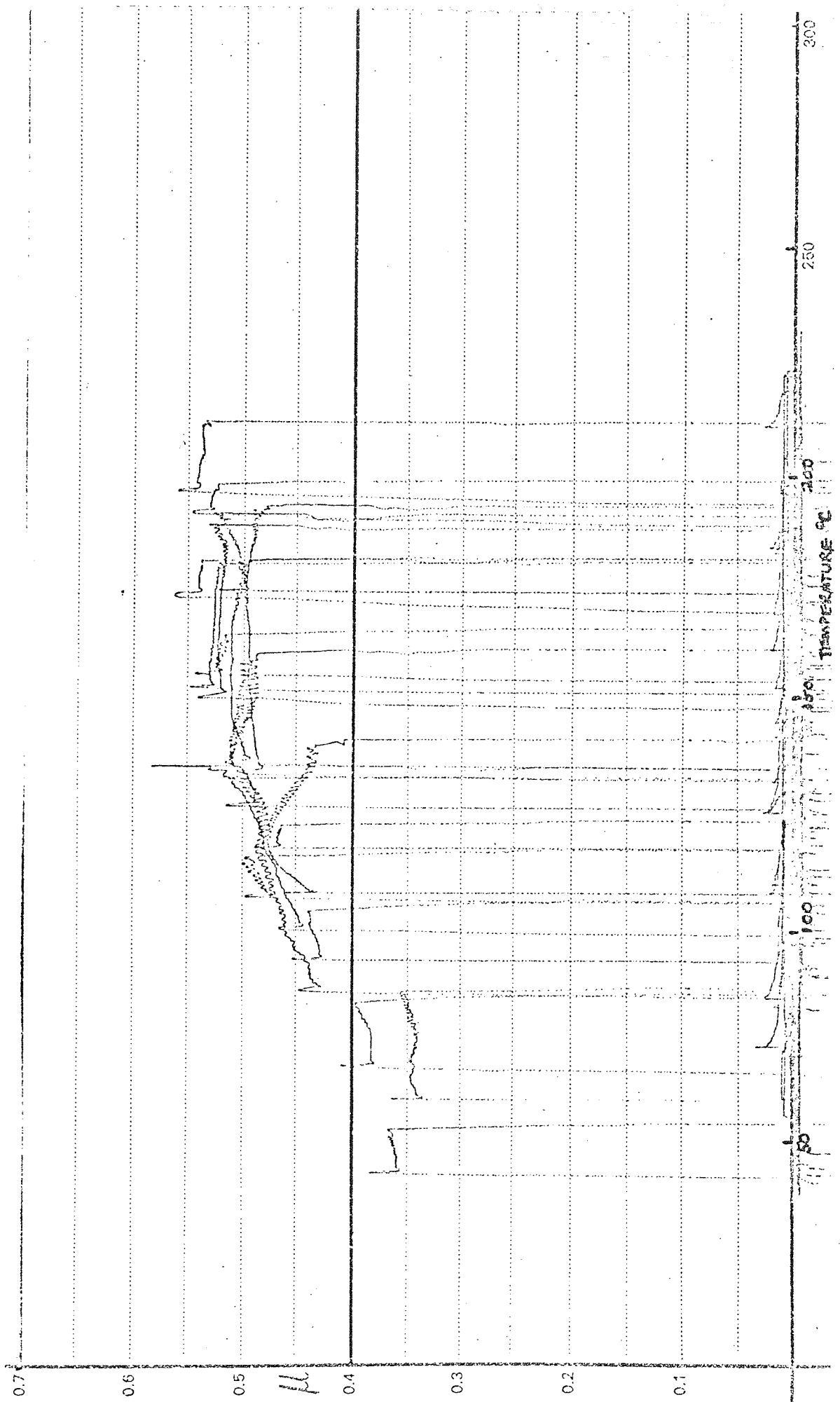

Fig.23

XY PLOT WITH A FULL COMPLIMENT OF BRAKE APPLICATIONS

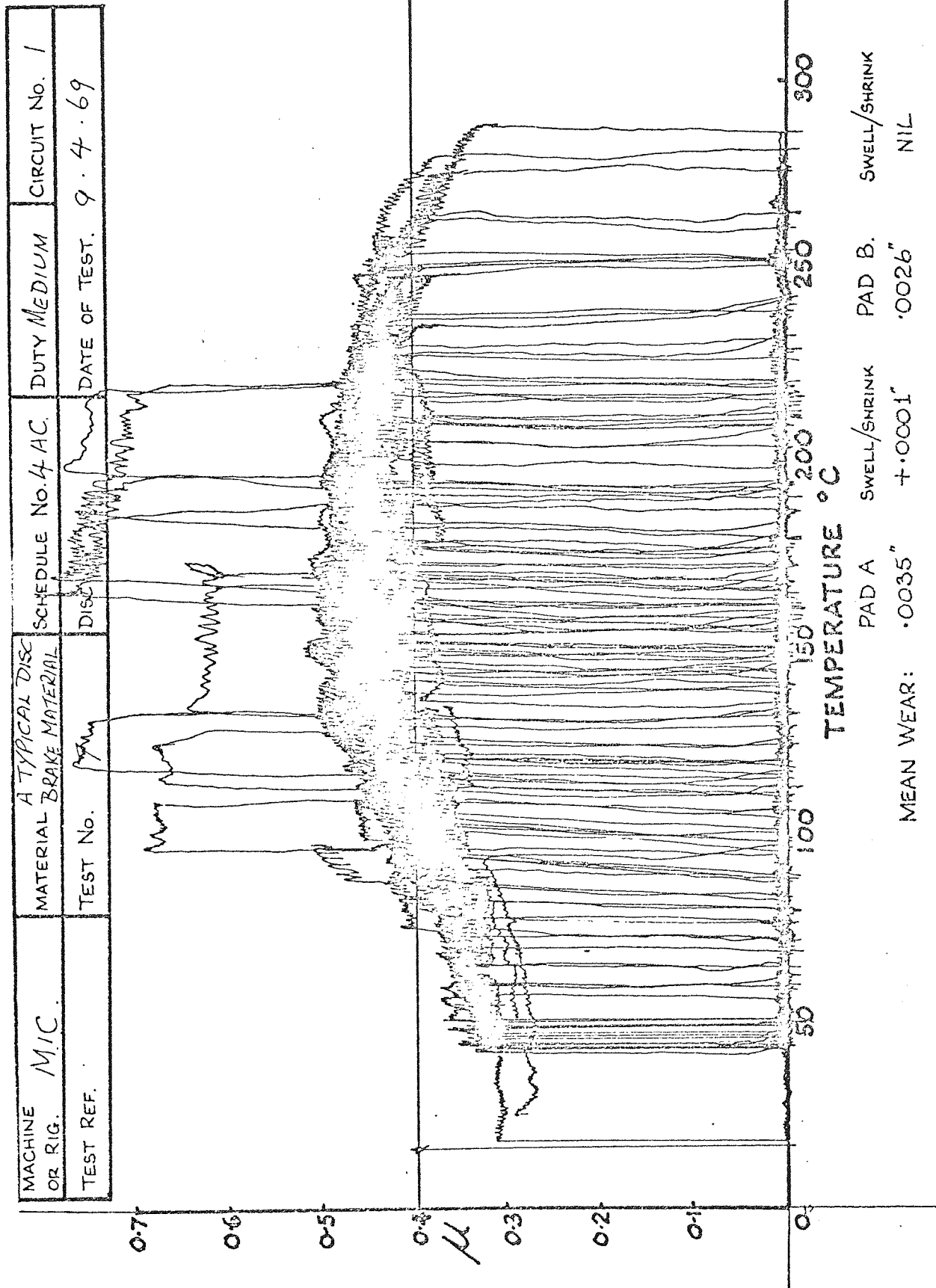

Fig. 24

FRICION/TIME PROFILE WITH CROSS CHECK ON CALCULATED
AVERAGE VALUE

A TYPICAL DISC BRAKE MATERIAL

μ / TEMPERATURE CHARACTERISTICS.

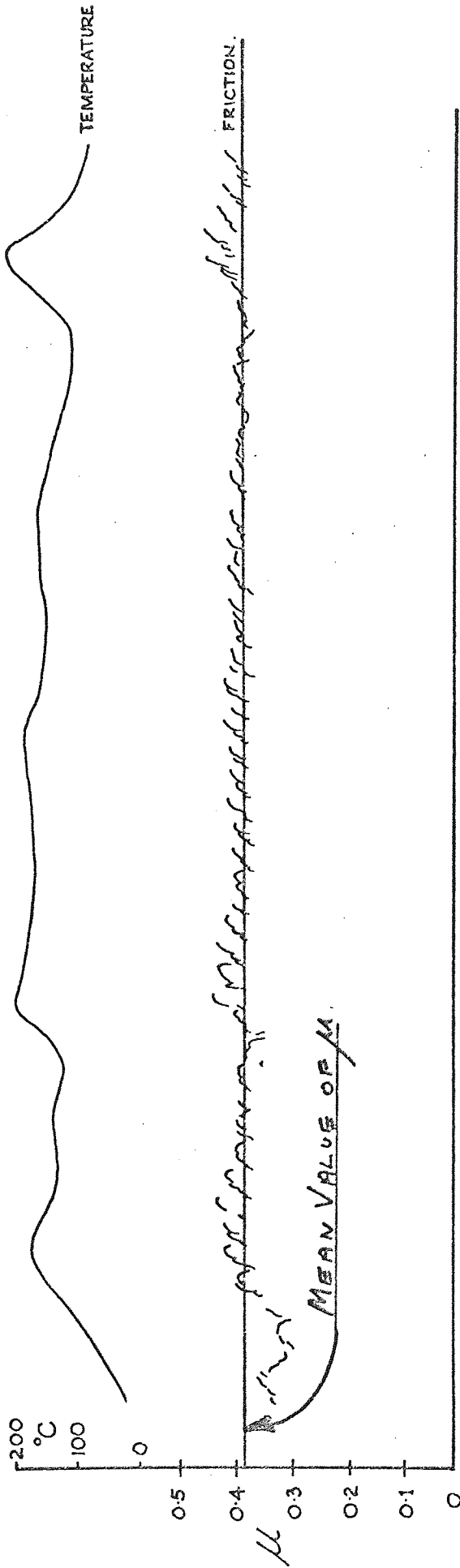
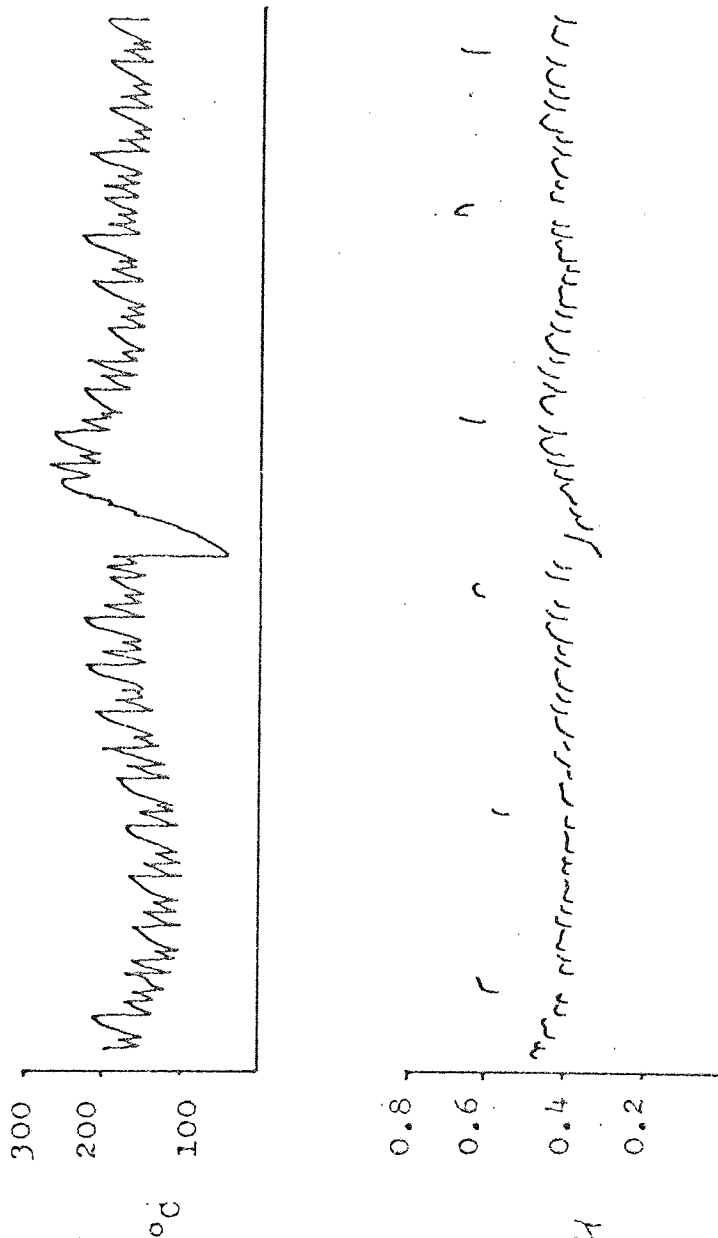

Fig. 25

MAL FUNCTION OF TEMPERATURE MONITOR



Application Number

Fig. 26

MEASURED μ/t CURVES WITH ERRORS IN SENSITIVITY

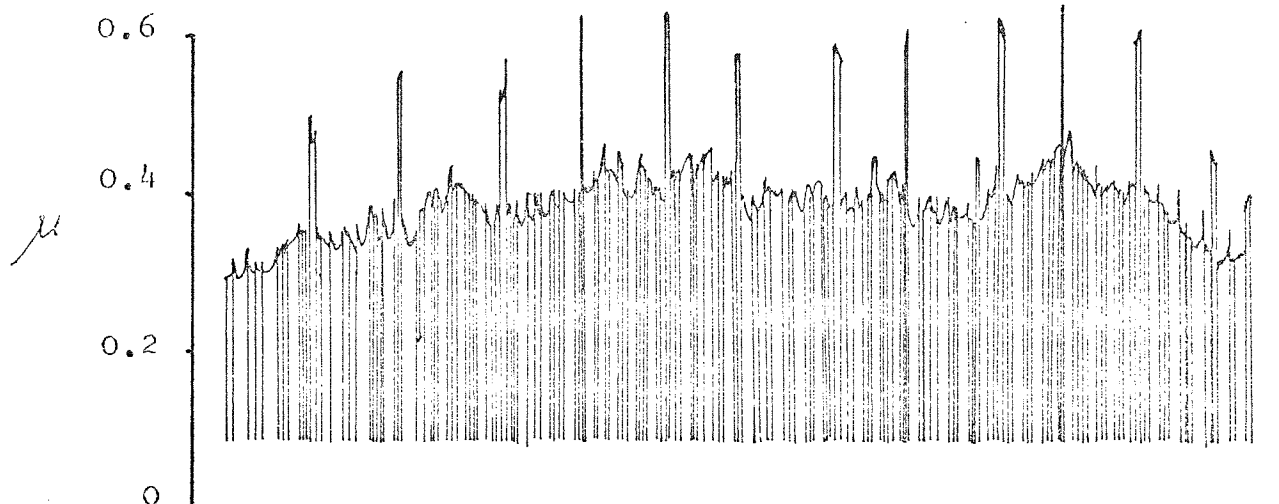

20% Decrease in Sensitivity

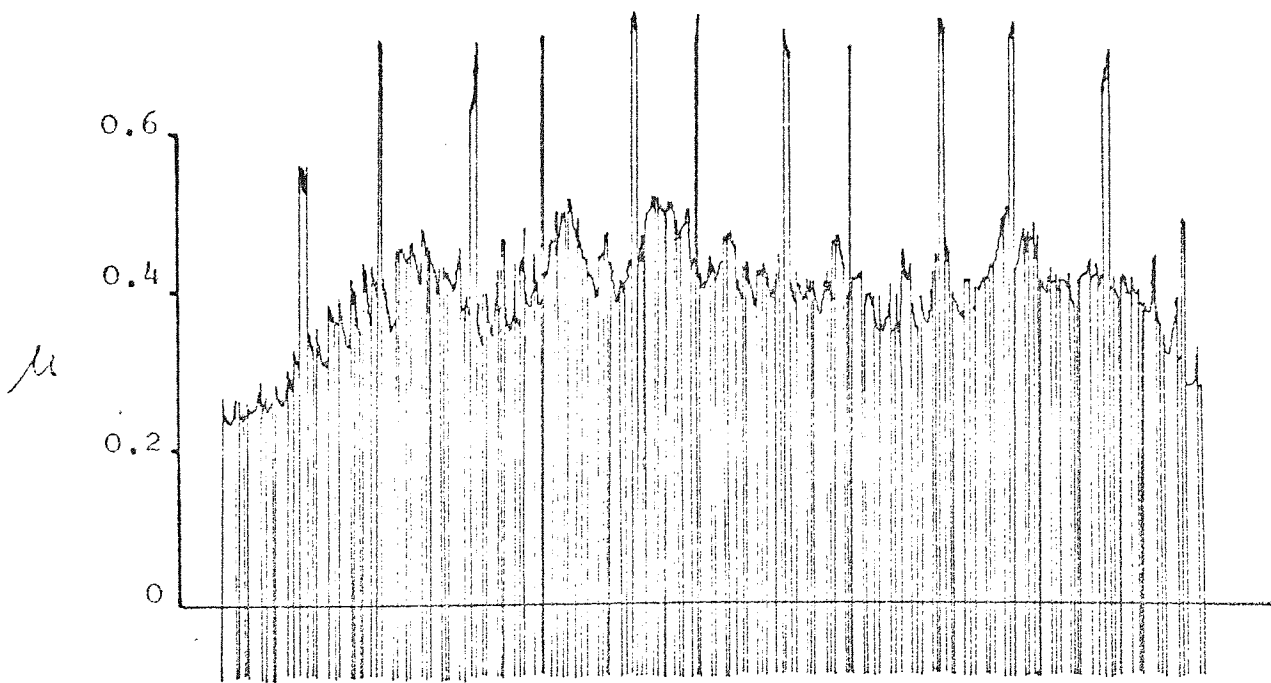

20% Increase in Sensitivity

Fig.27

ALTERNATE TESTS ON TWO SIMILAR MATERIALS

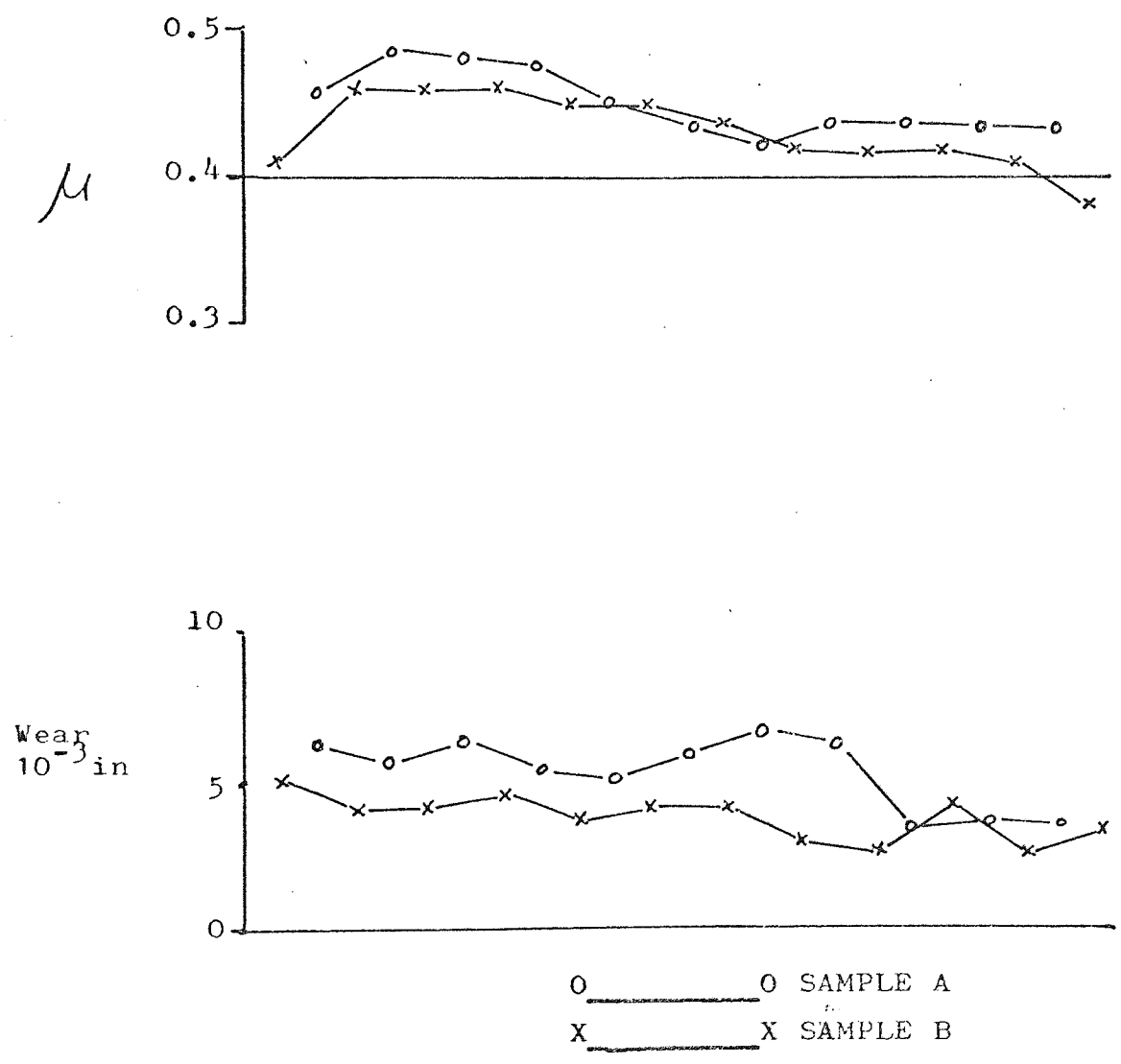

Fig. 28

GRAPH OF WEAR PER CIRCUIT SHOWING DEGREE OF SCATTER

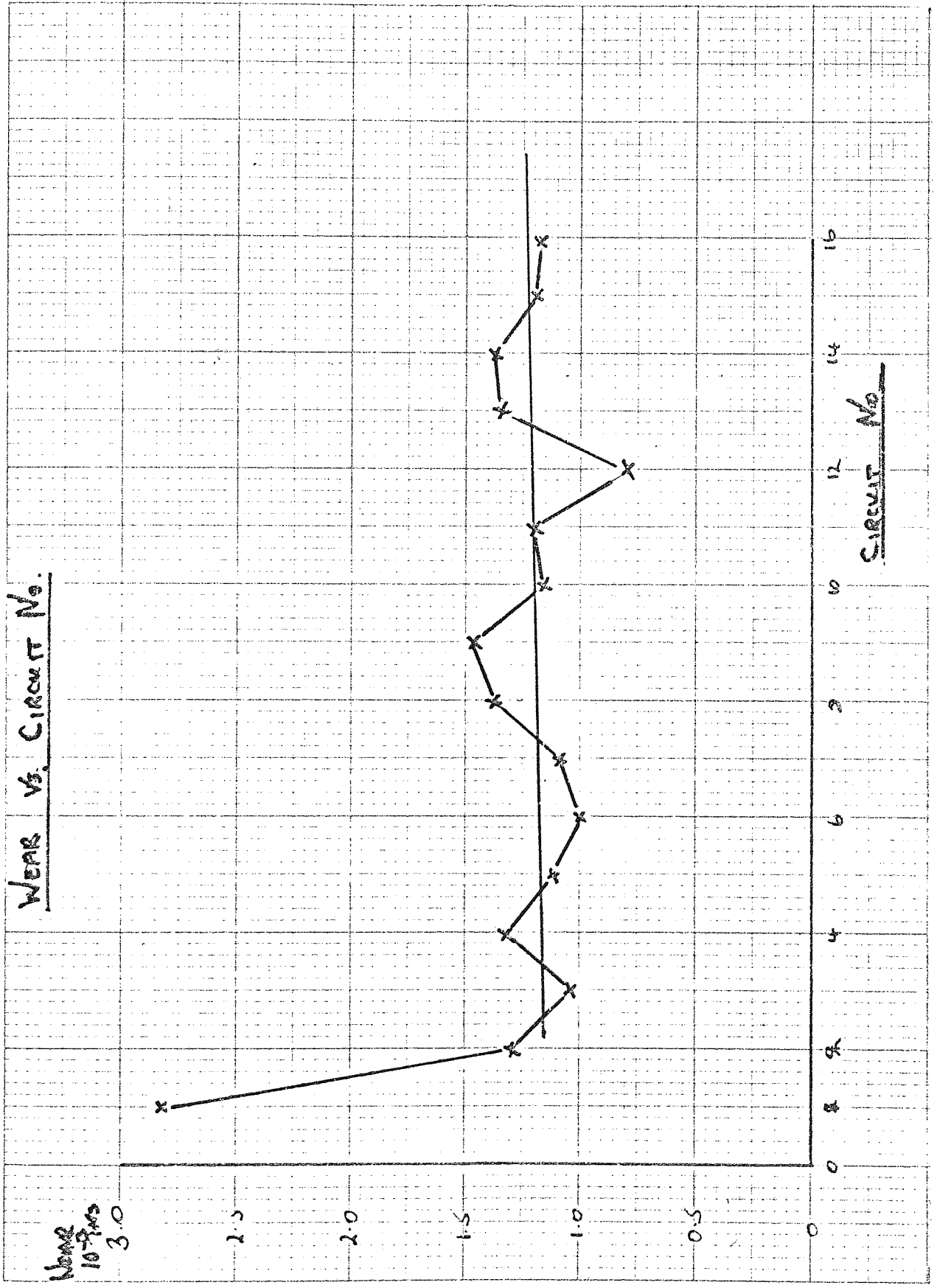

Fig. 29

MODERATE DUTY TESTS PERFORMED CONSECUTIVELY, AT INTERVALS OF ONE WEEK AND ON NEW SAMPLES

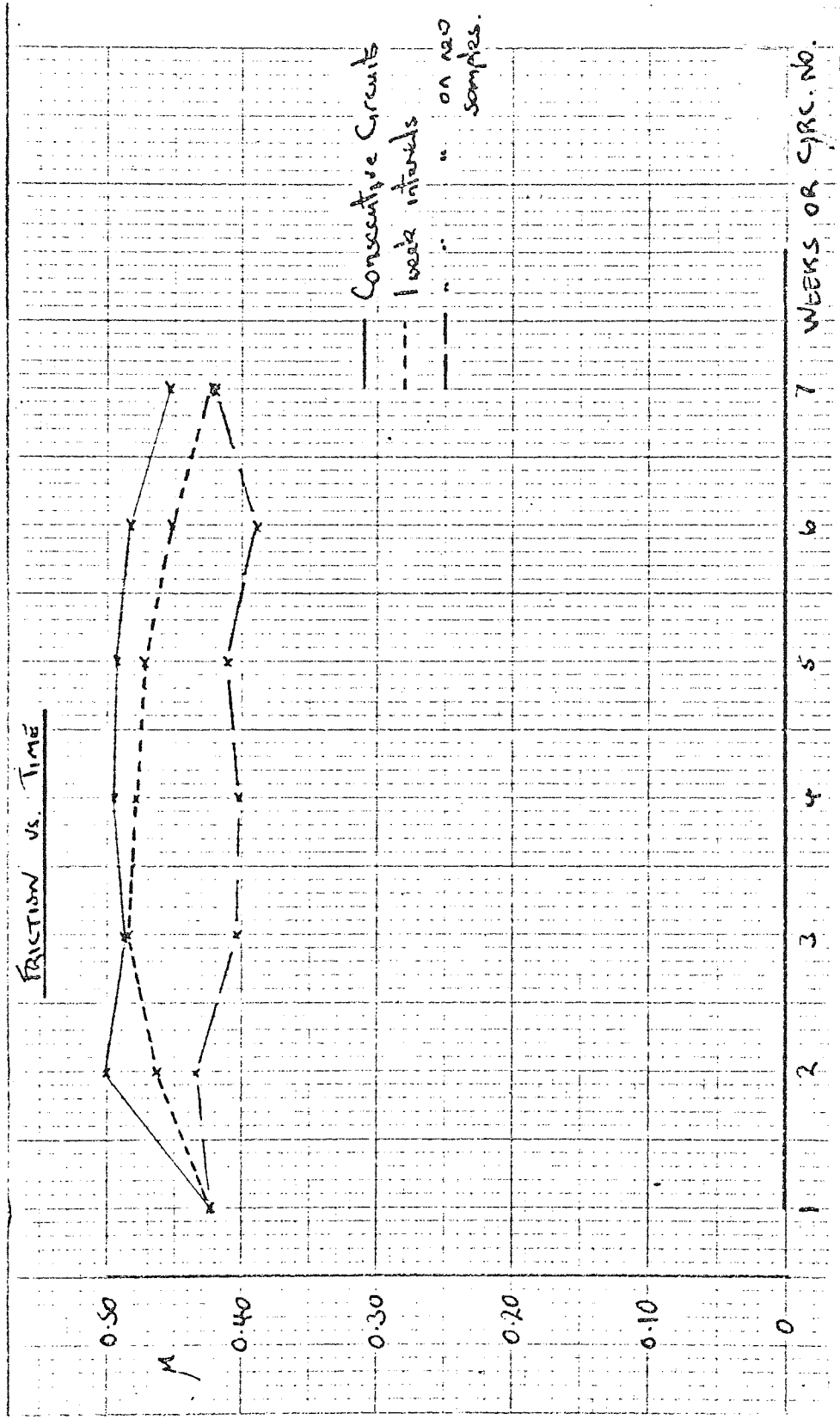

Fig. 30

TABLE OF SOURCES OF VARIANCE

	STANDARD DEVIATION				
	COEFFICIENT OF FRICTION			WEAR	
	WITHIN SAMPLE	WITHIN BATCH	BETWEEN BATCHES	10^{-3} INS.	% AGE OF AVERAGE
MATERIAL 'A'	0.003	0.015	0.015	0.225	4.5
MATERIAL 'B'	0.003	0.005	0.015	0.225	5.6
MATERIAL 'C'	0.003	0.020	0.020	0.070	5.4
MATERIAL 'D'	0.005	0.008	0.008	0.225	7.5

Fig.31

THE COMPLETE CONTROLLER/RESULTS PLOTTER

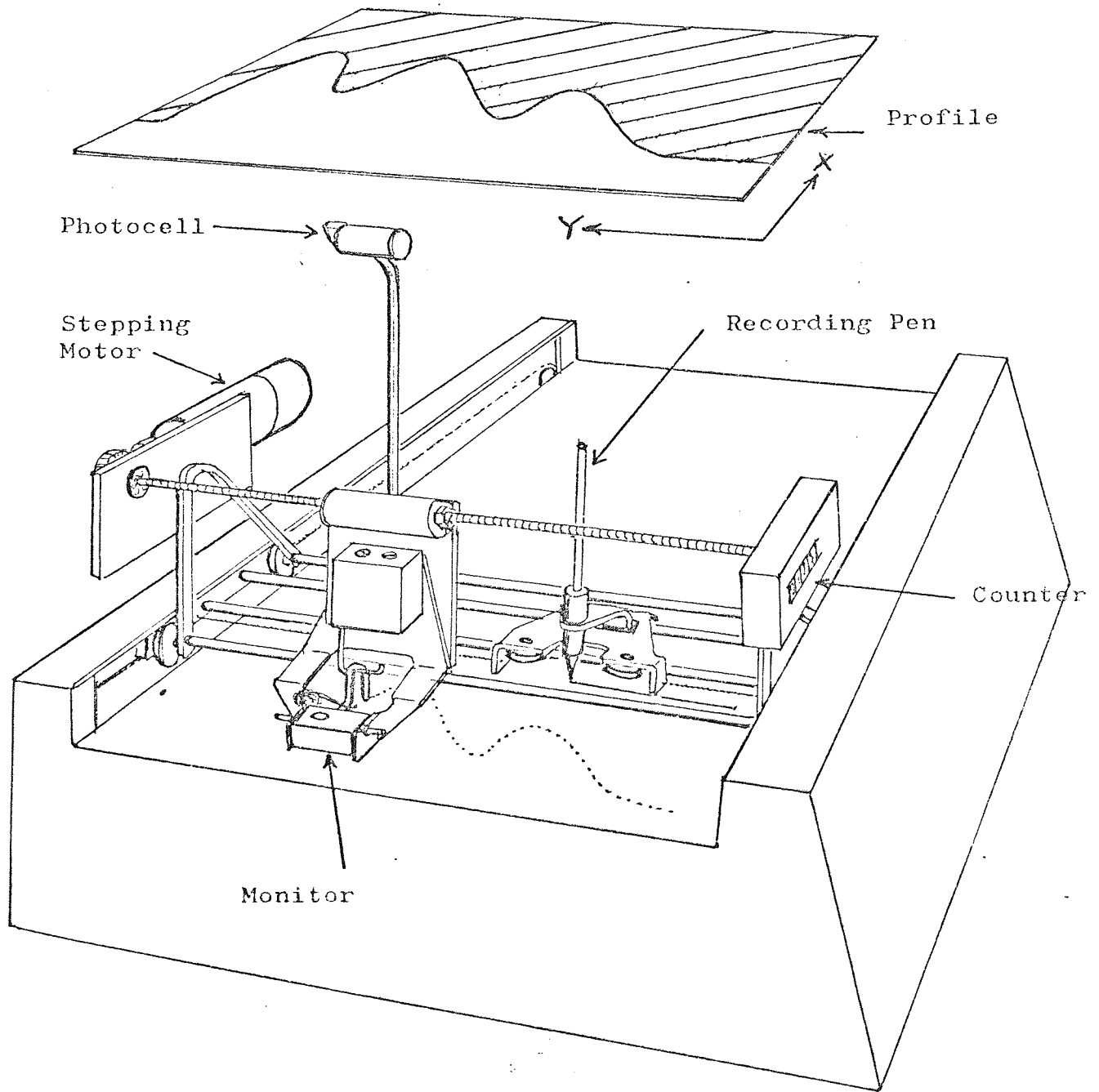

Fig. 32

FRICITION/TEMPERATURE ENVELOPE WITH
TEMPERATURE MONITOR AND PARALLEL
LOCATION LINES

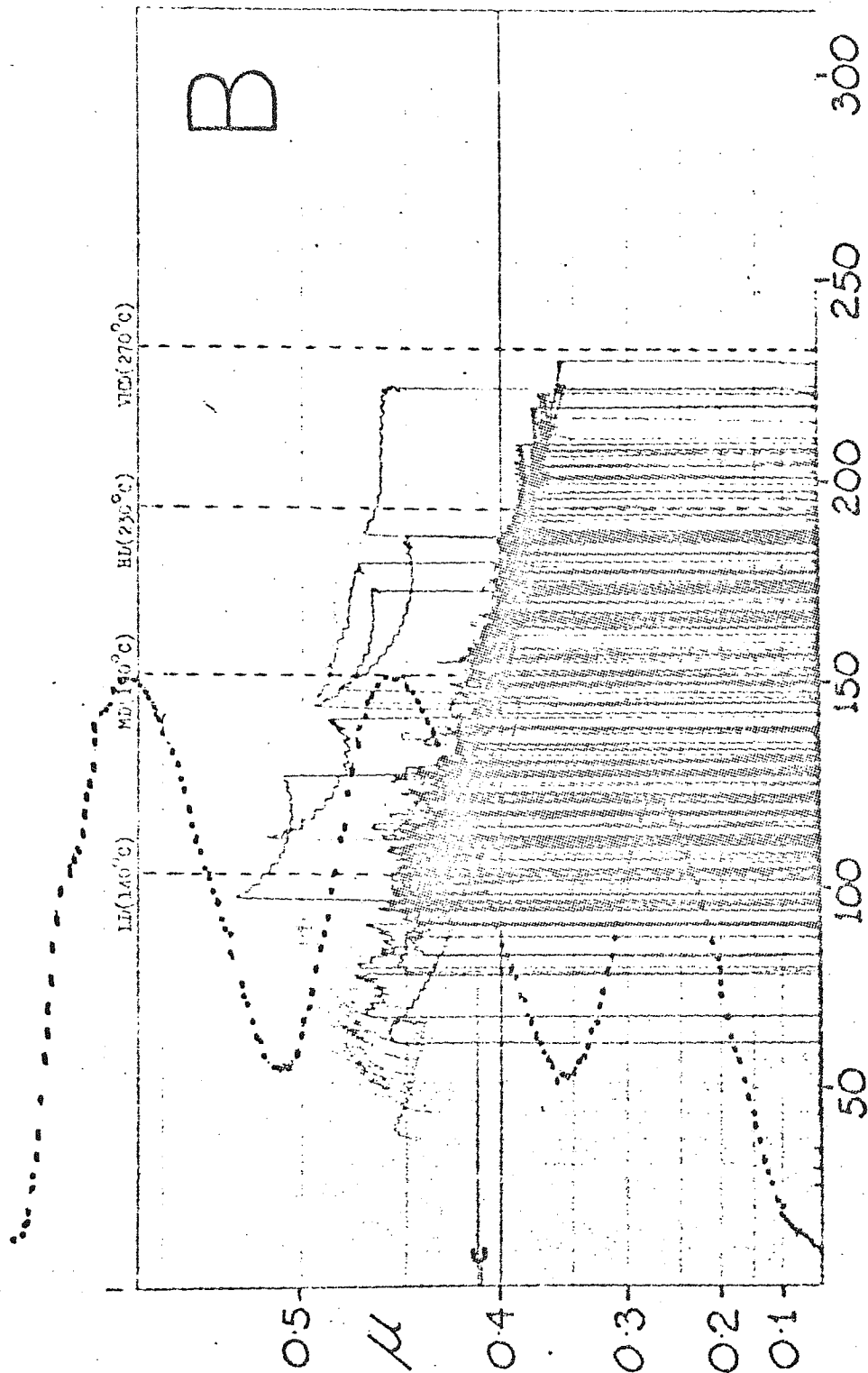

Fig. 33

CIRCUIT DIAGRAM OF RE-TRANSMITTING SLIDE WIRE

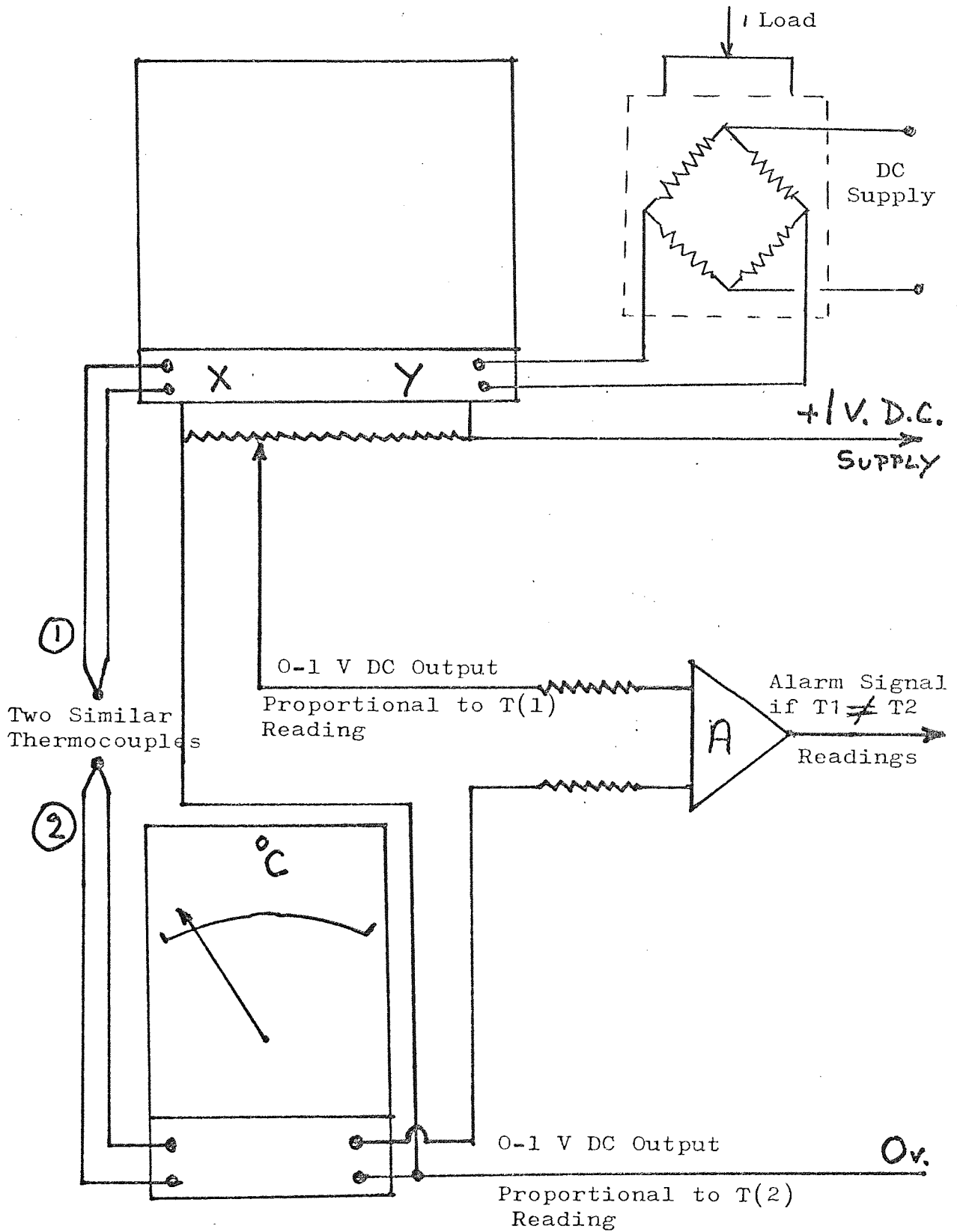

Fig.34

PATCH BOARD CIRCUIT DIAGRAM

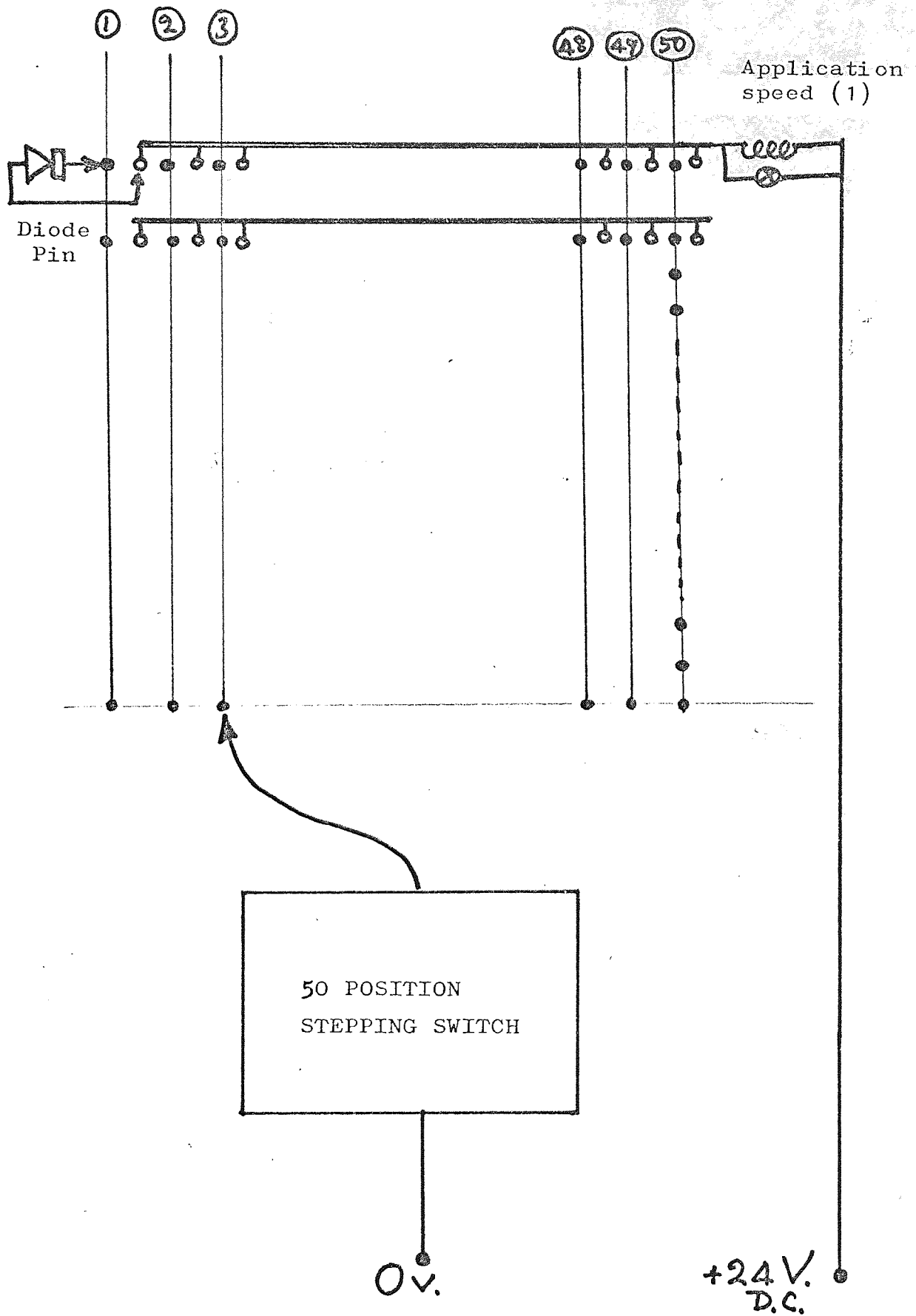

Fig.35

THE COMPLETE CONTROLLER/RESULT PLOTTER WITH DYNAMOMETER

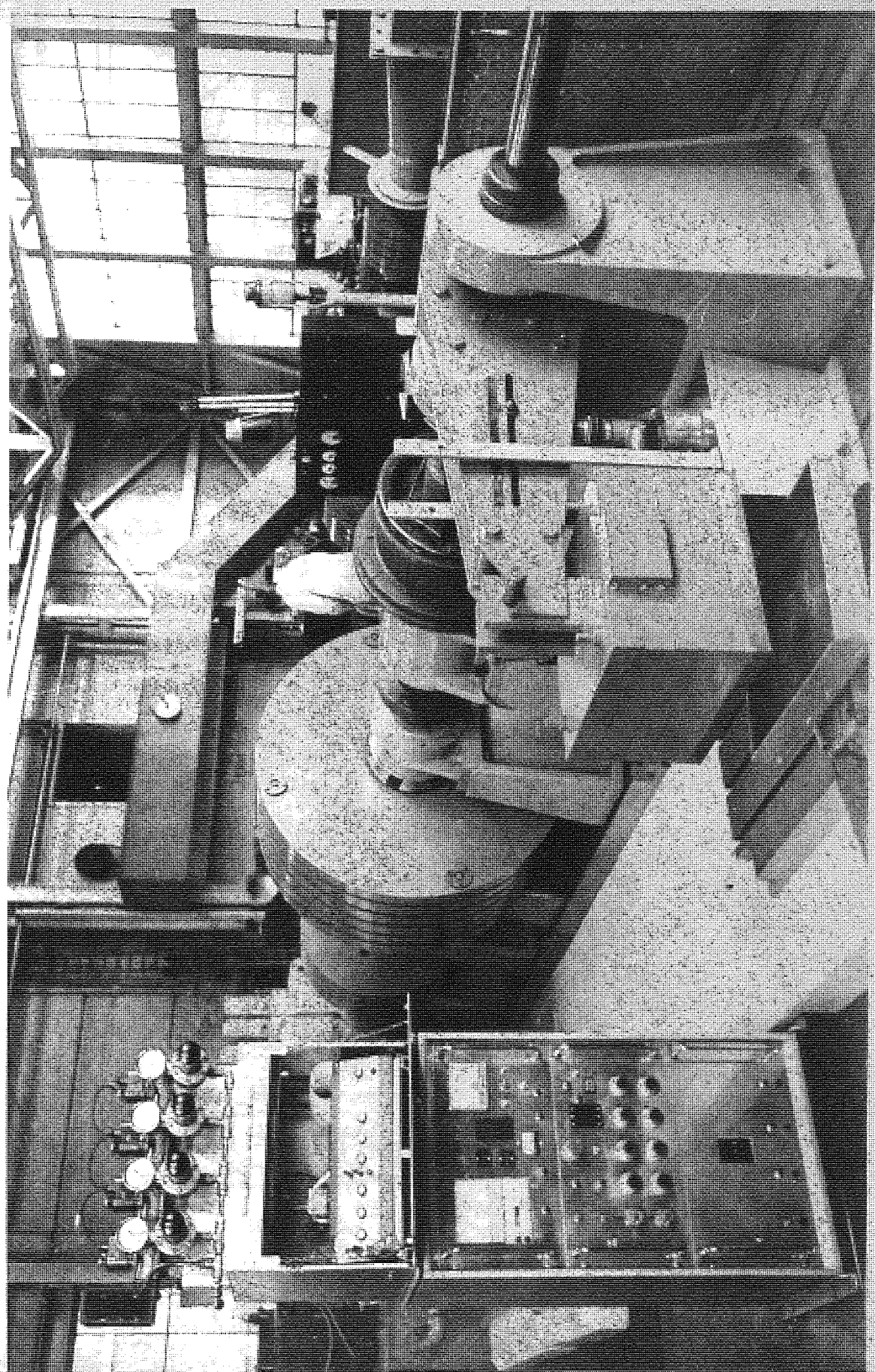

Fig.36

TYPICAL LIGHT, MEDIUM AND HEAVY DUTY CIRCUITS
WITH TEMPERATURE PROFILE

TYPICAL LIGHT, MEDIUM AND HEAVY DUTY CIRCUITS.

A) LIGHT B) MEDIUM C) HEAVY D) NORMAL POSITIONING OF TEMPERATURE MONITOR

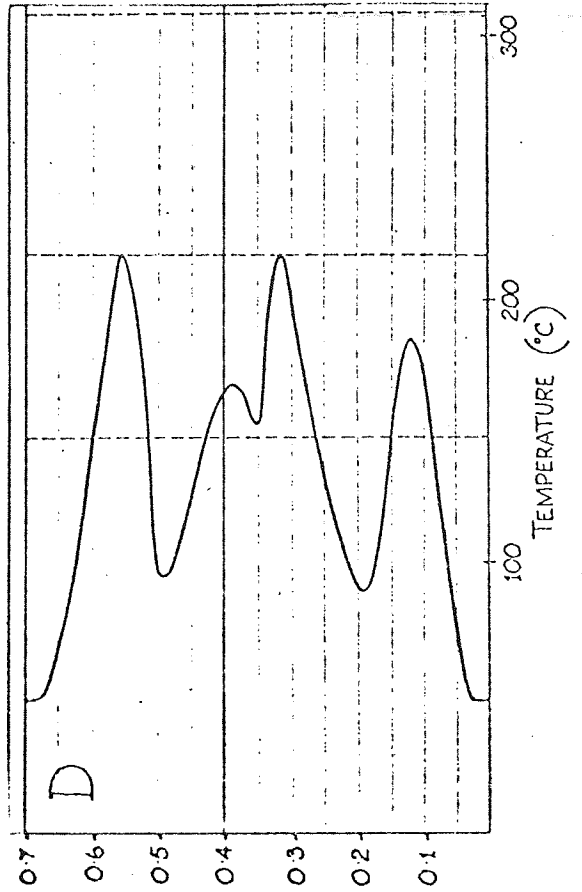
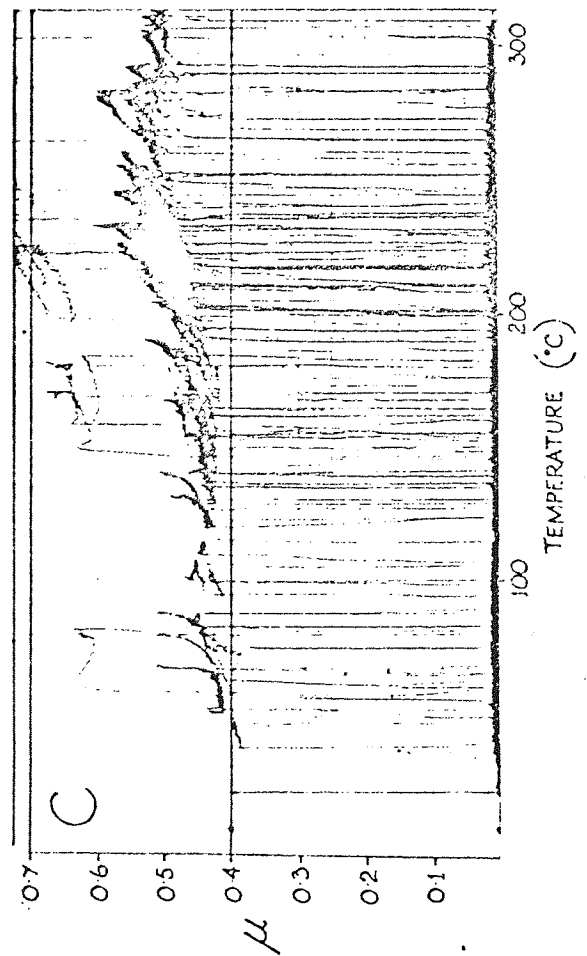
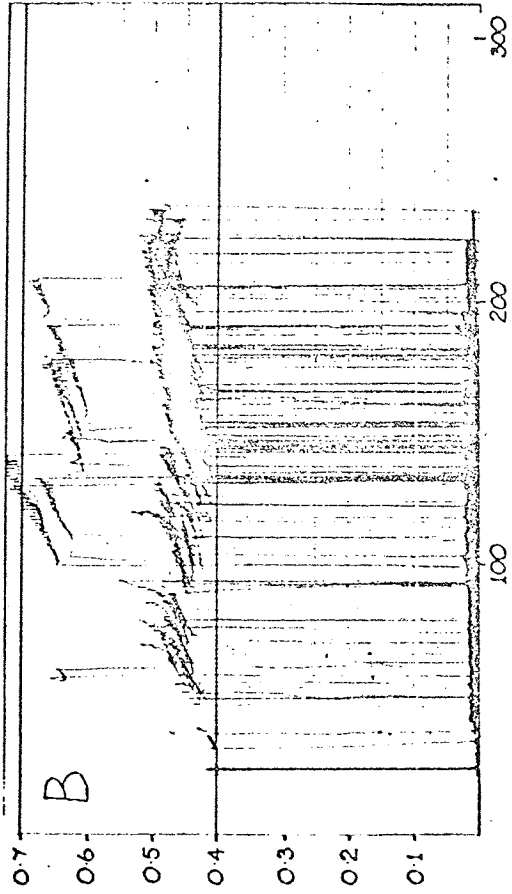
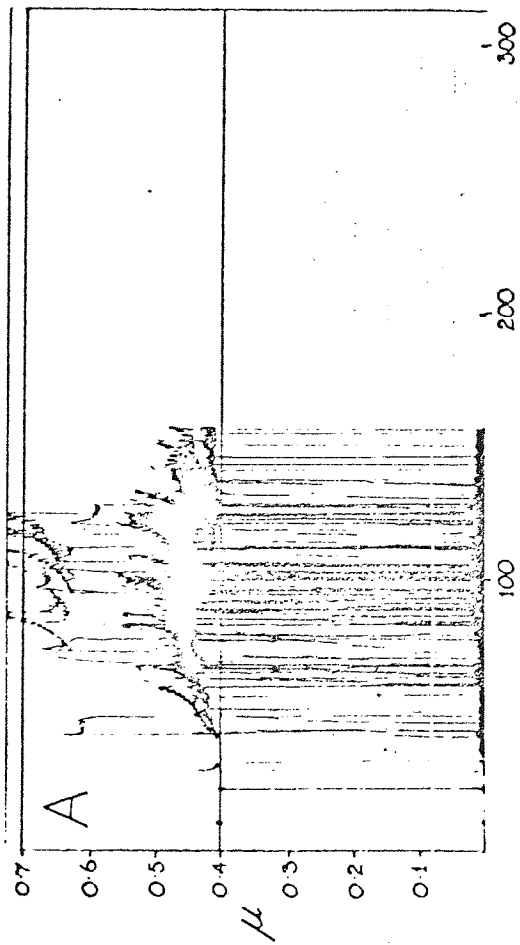

Fig. 37

EFFECT OF CONTINUAL TESTING ON A SINGLE DISC

EFFECT OF DISC USAGE A) TEST 1. B) TEST 13. C) TEST 26. D) TEST 27

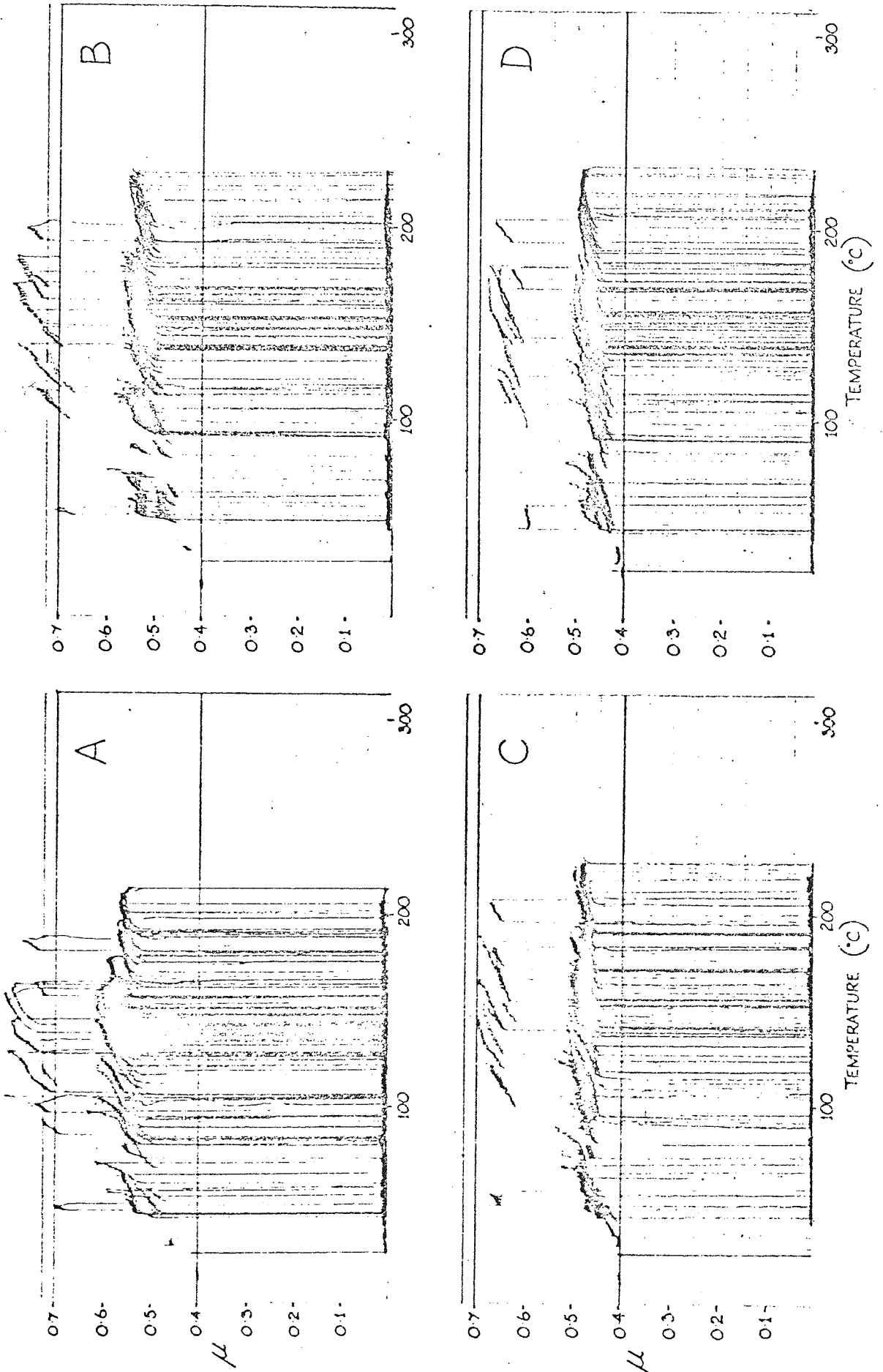

Fig. 38

EFFECT ON PERFORMANCE OF VARYING ONE
CONSTITUENT OF THE FRICTION MATERIAL

EFFECT OF INCLUSION OF A COMMON CONSTITUENT OF DISC BRAKE PADS A) 0 UNITS B) 0.5 UNITS C) 10 UNITS D) 15 UNITS.

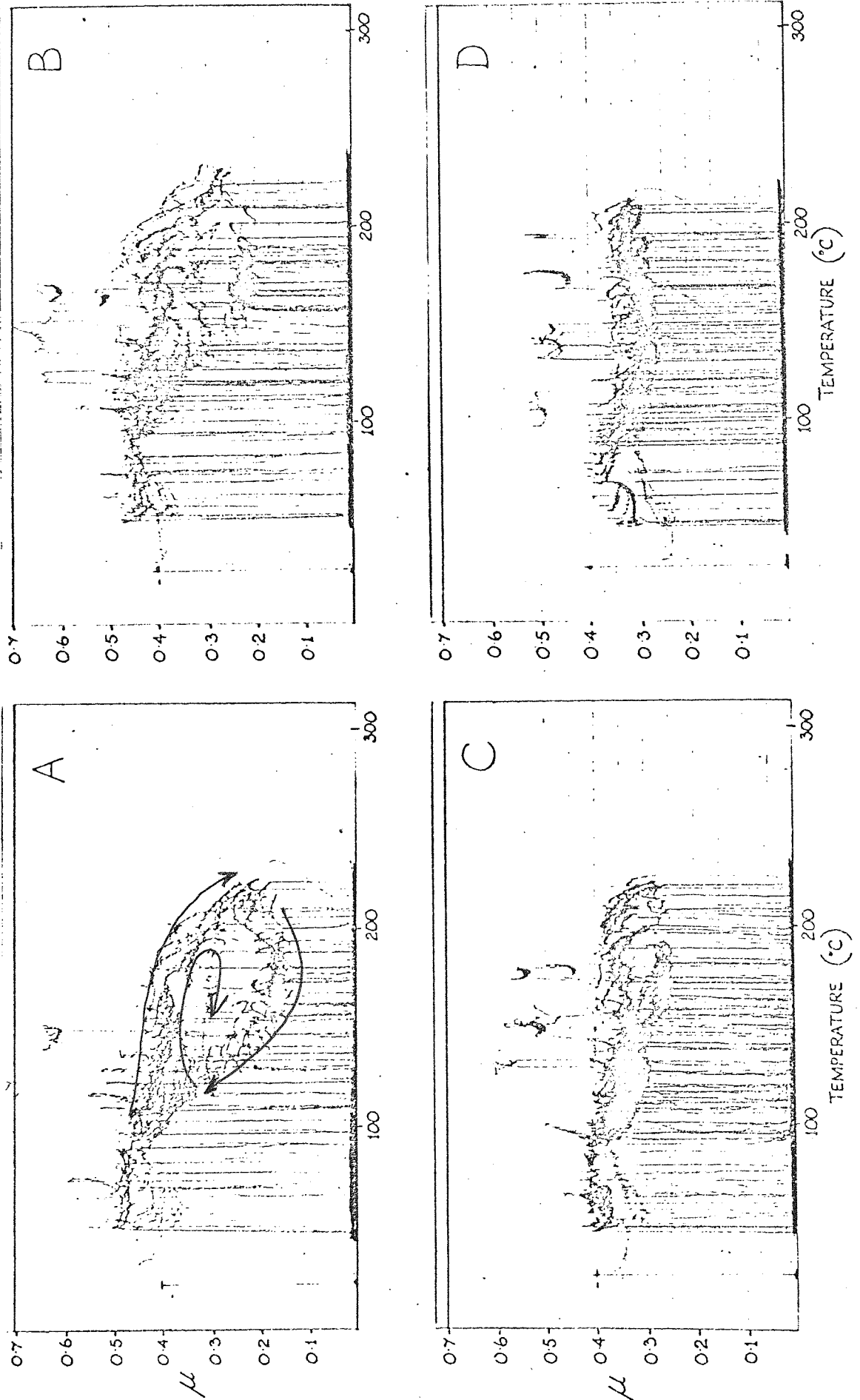

Fig. 39

TYPICAL RESULTS OBTAINED ON A LARGE
COMMERCIAL VEHICLE DRUM BRAKE

TYPICAL LIGHT, MEDIUM, HEAVY AND VERY HEAVY DUTY CIRCUITS. A) LIGHT B) MEDIUM C) HEAVY D) VERY HEAVY.

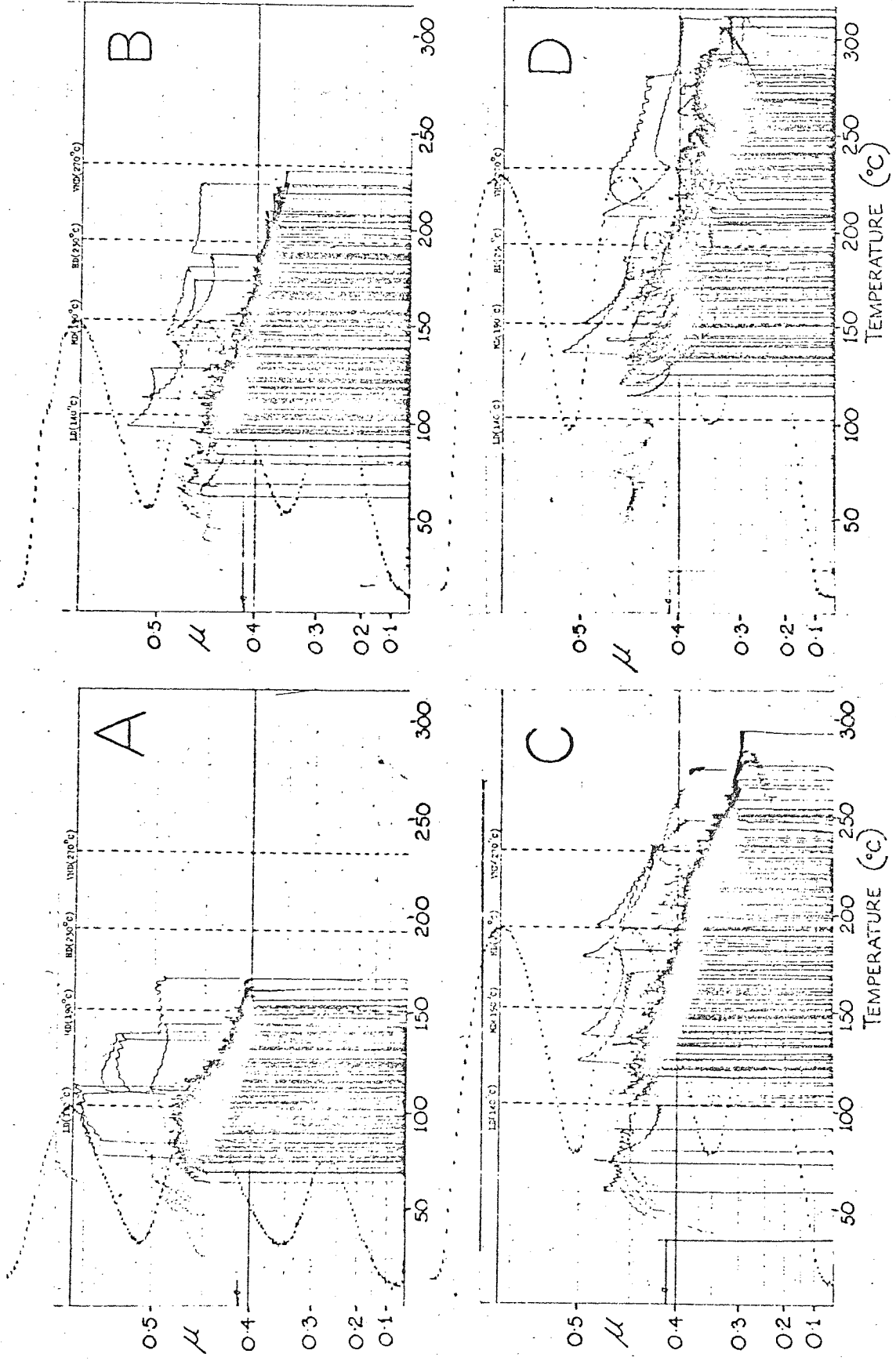
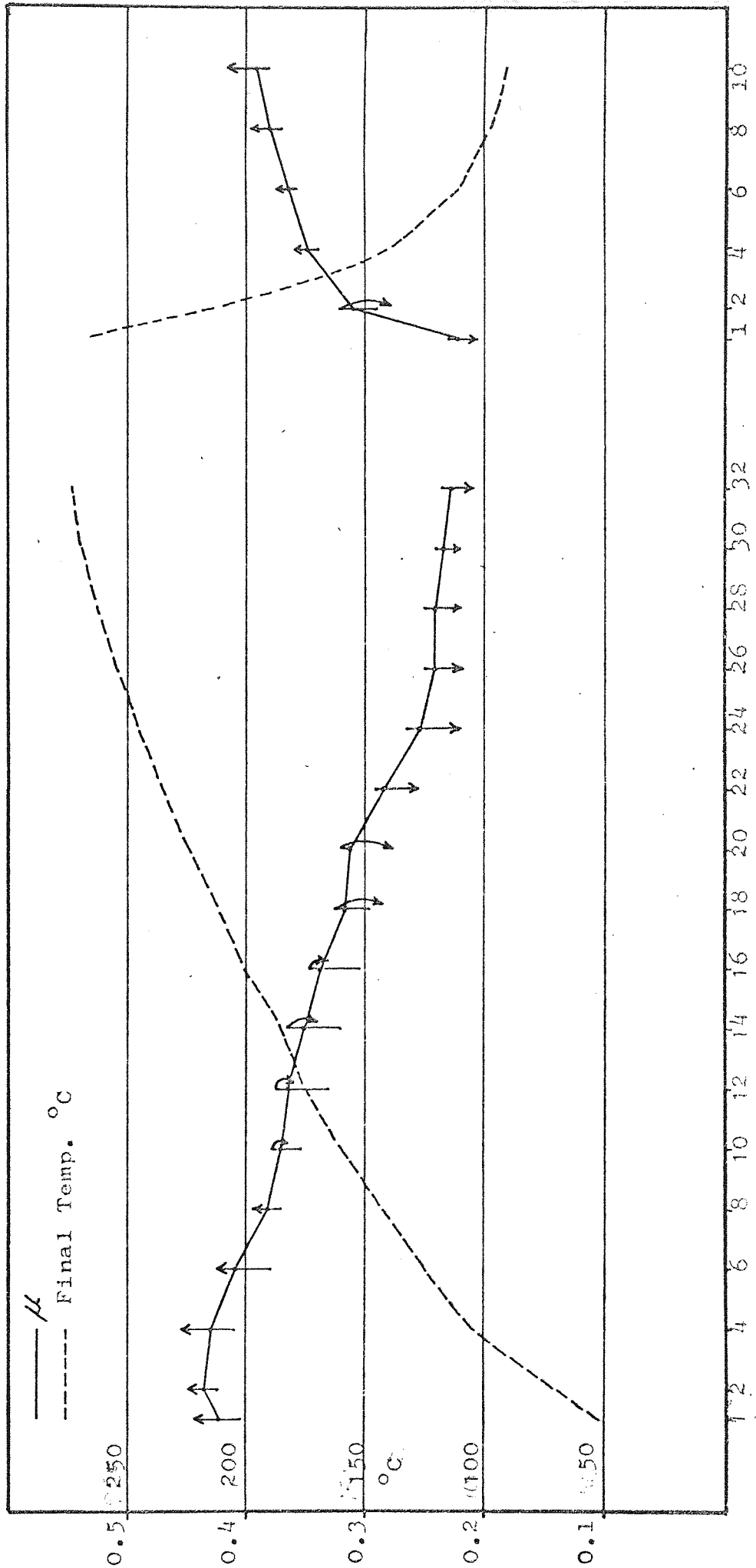

Fig.40

CONVENTIONAL FADE TEST PRESENTATION FOR A LARGE COMMERCIAL VEHICLE DRUM BRAKE

RECOVERY TEST

FADE TEST



STOP NUMBER

Fig. 41

FADE AND RECOVERY TEST AS IN FIG. 41 BUT
PLOTTED BY XY PLOTTER

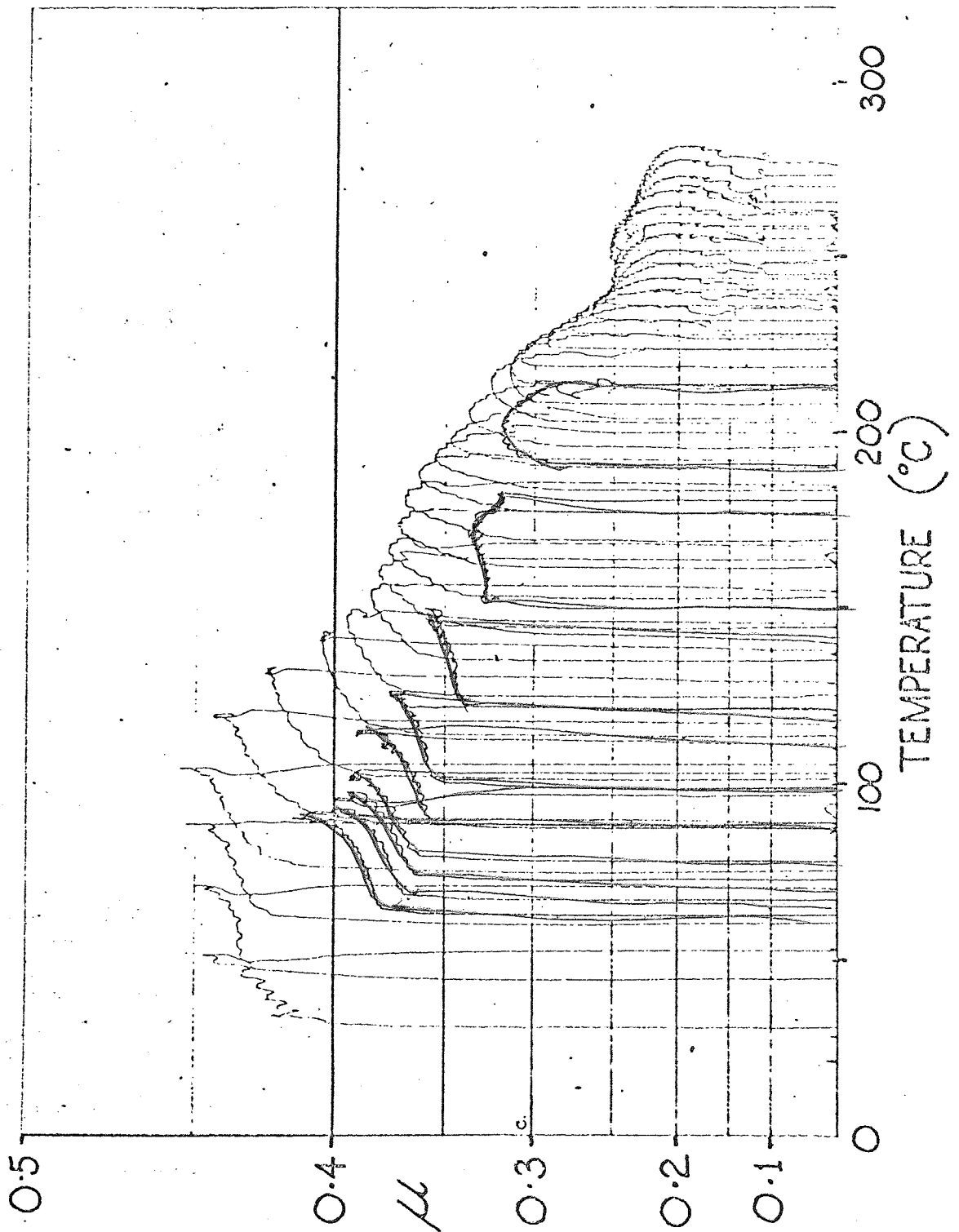
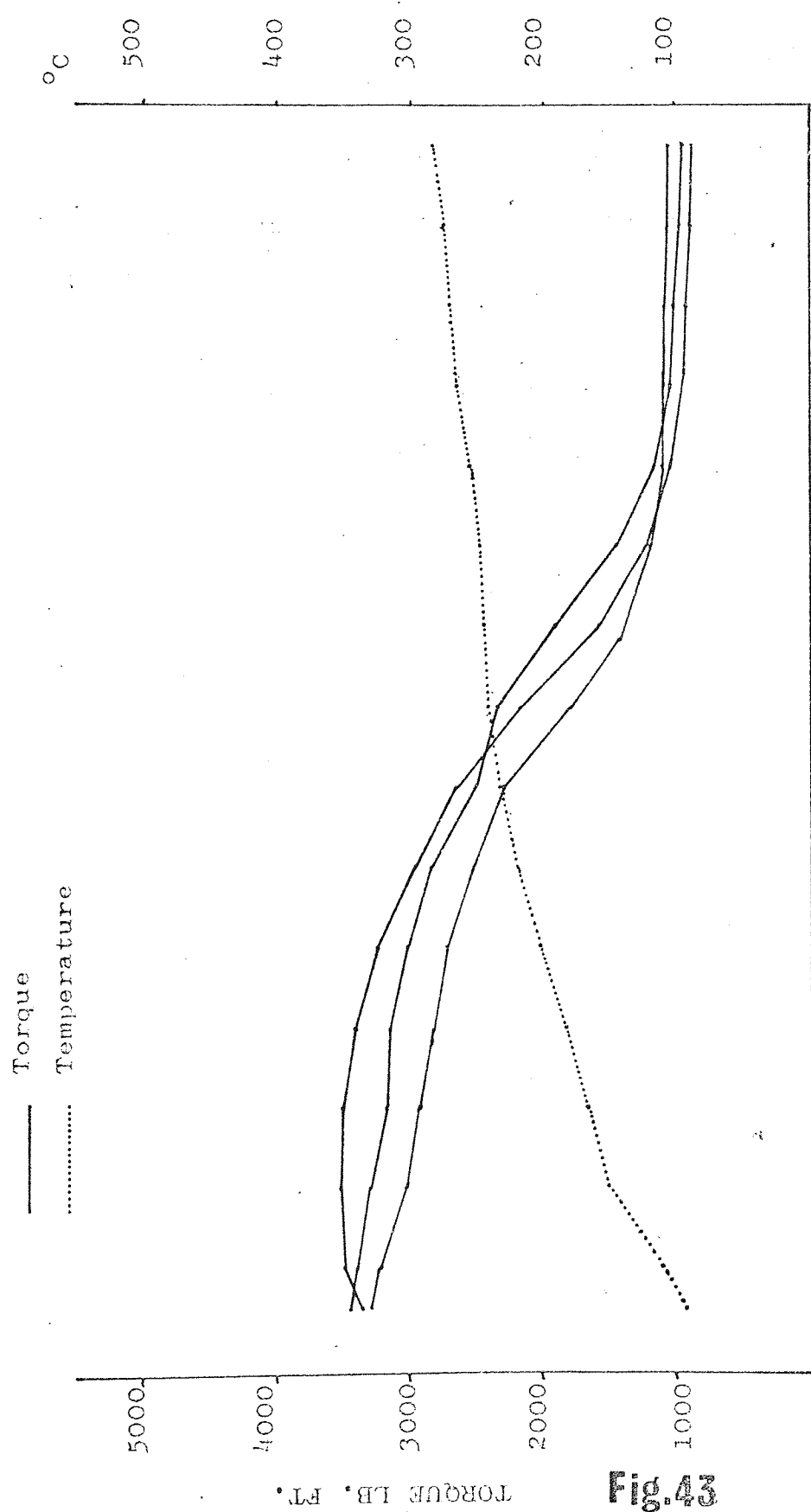

Fig.42

FADE TESTS CONTROLLED BY TEMPERATURE PROFILE



APPLICATION NUMBER

TORQUE LB. FT.

Fig. 43

THREE FADE TESTS AT SLIGHTLY DIFFERENT
TEMPERATURE CONDITIONS

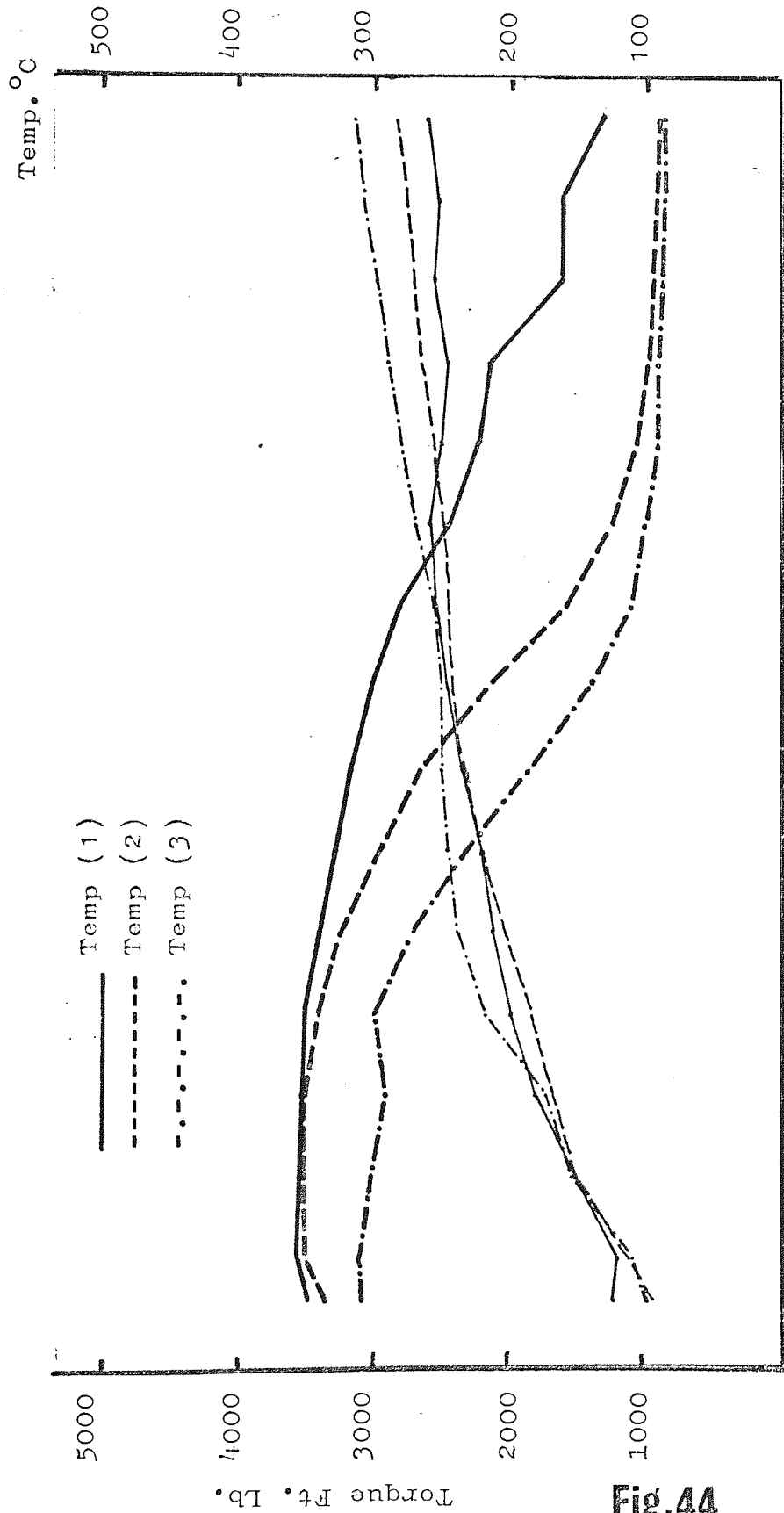

Fig.44

APPLICATION NUMBER

VARIATION IN PERFORMANCE BETWEEN CAST IRON DISCS
TO THE SAME SPECIFICATION

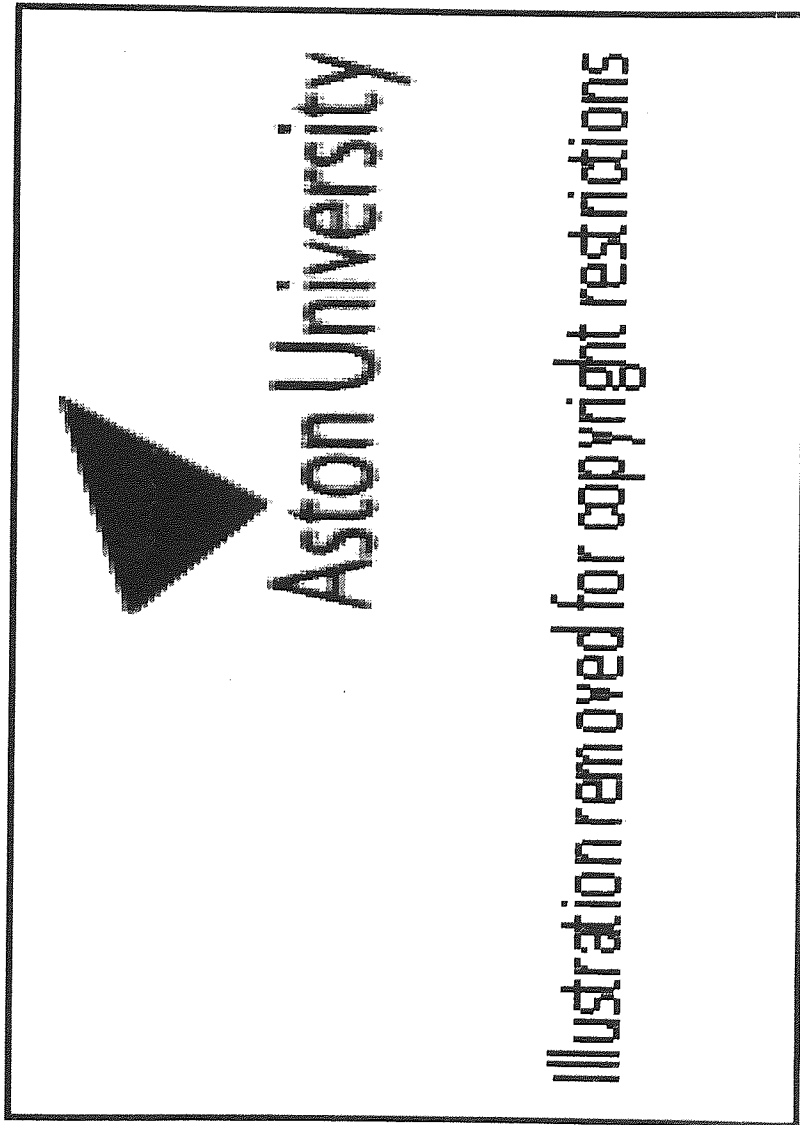
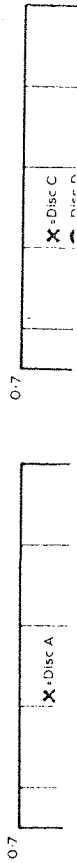

Fig. 45

H Y 48

Fig 3

Fig 4

NOISE MEASUREMENT THROUGHOUT A TEMPERATURE
PROGRAMMED TEST

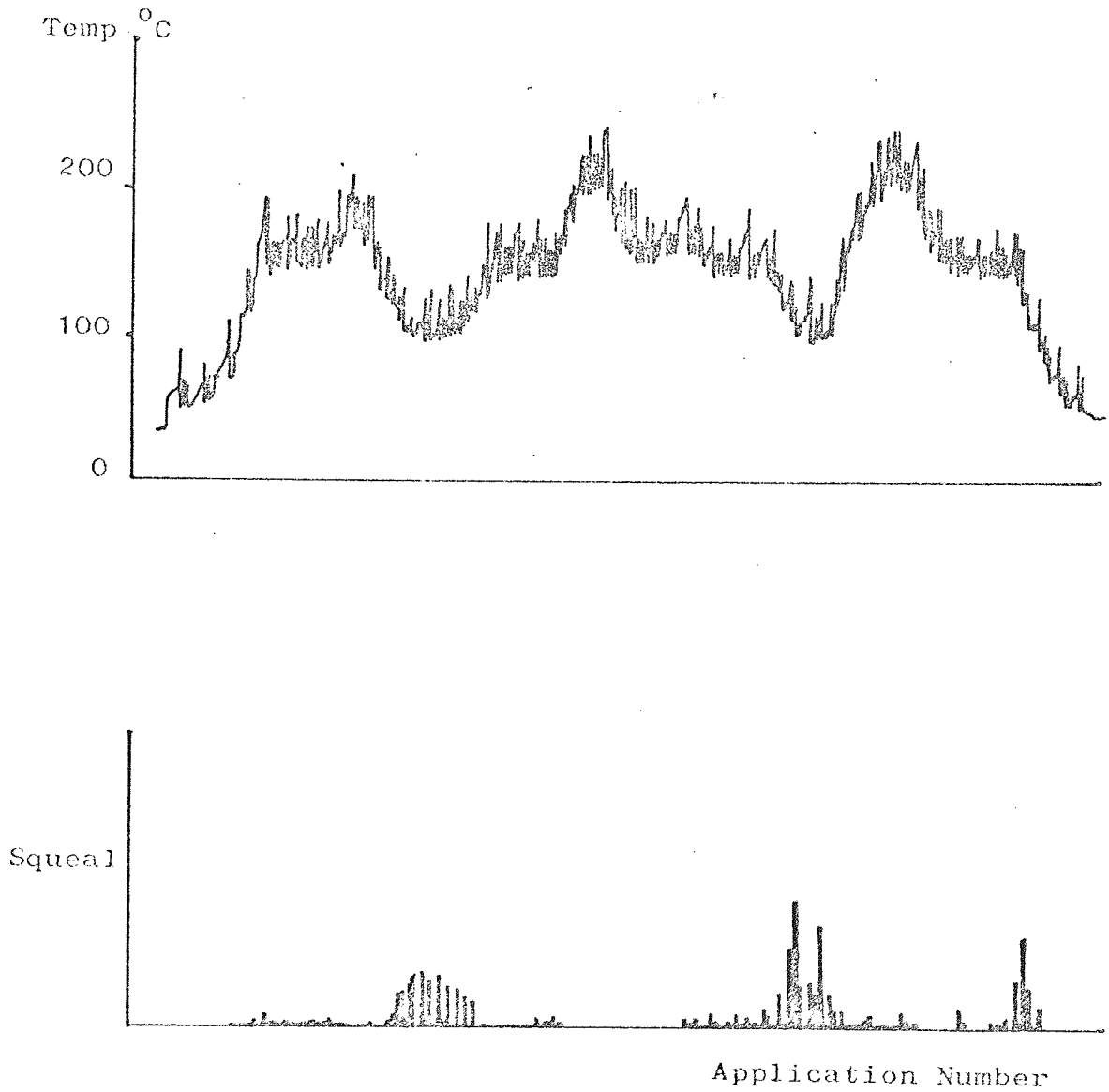

Fig. 46

TWELVE INDIVIDUAL BRAKE APPLICATIONS FROM
THE 9TH TEST CIRCUIT

CIRCUIT No. 9

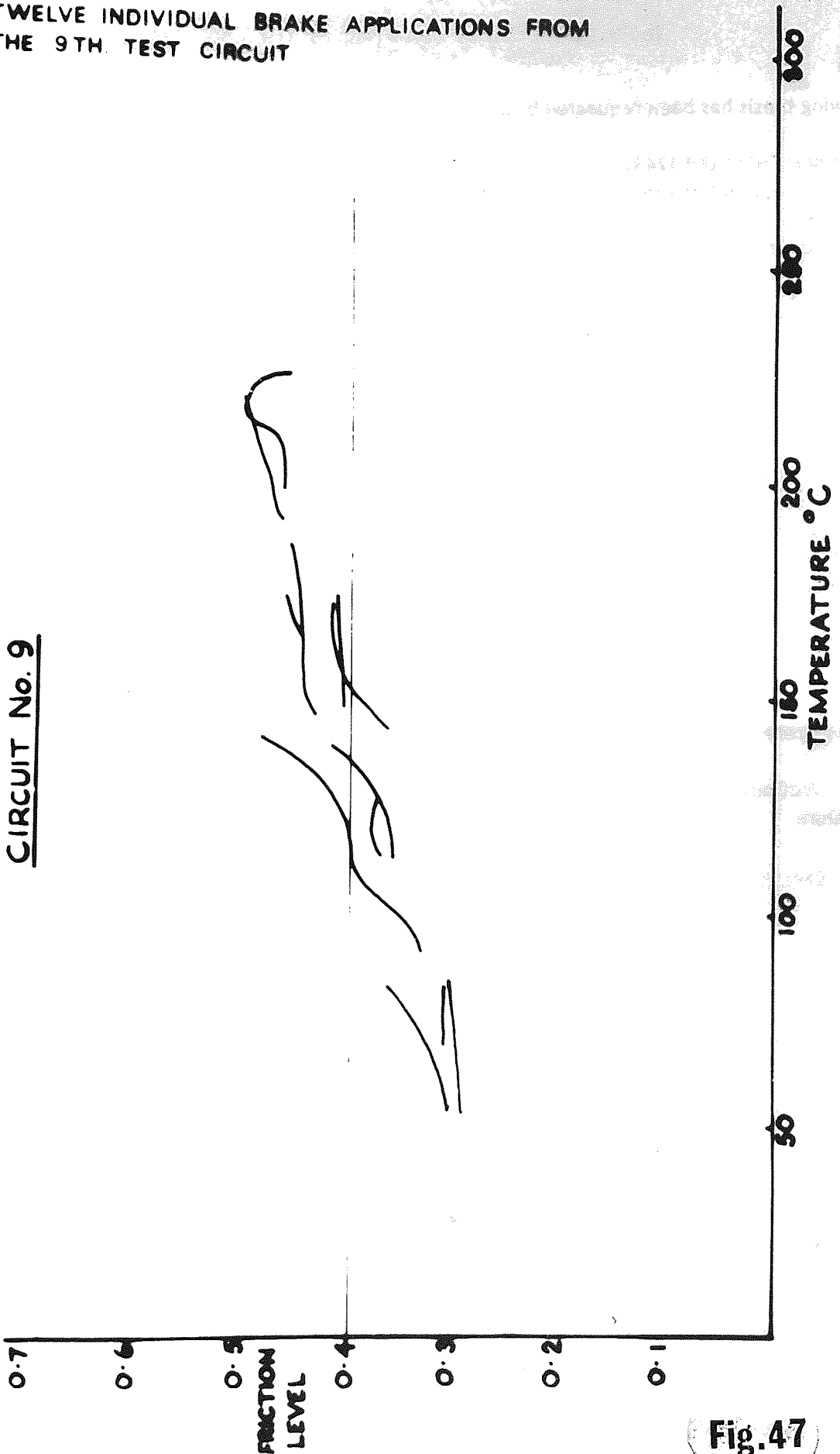

Fig. 47

THE SAME TWELVE INDIVIDUAL BRAKE APPLICATIONS
AS IN FIG. 46 FROM THE 12TH TEST CIRCUIT

CIRCUIT No. 12

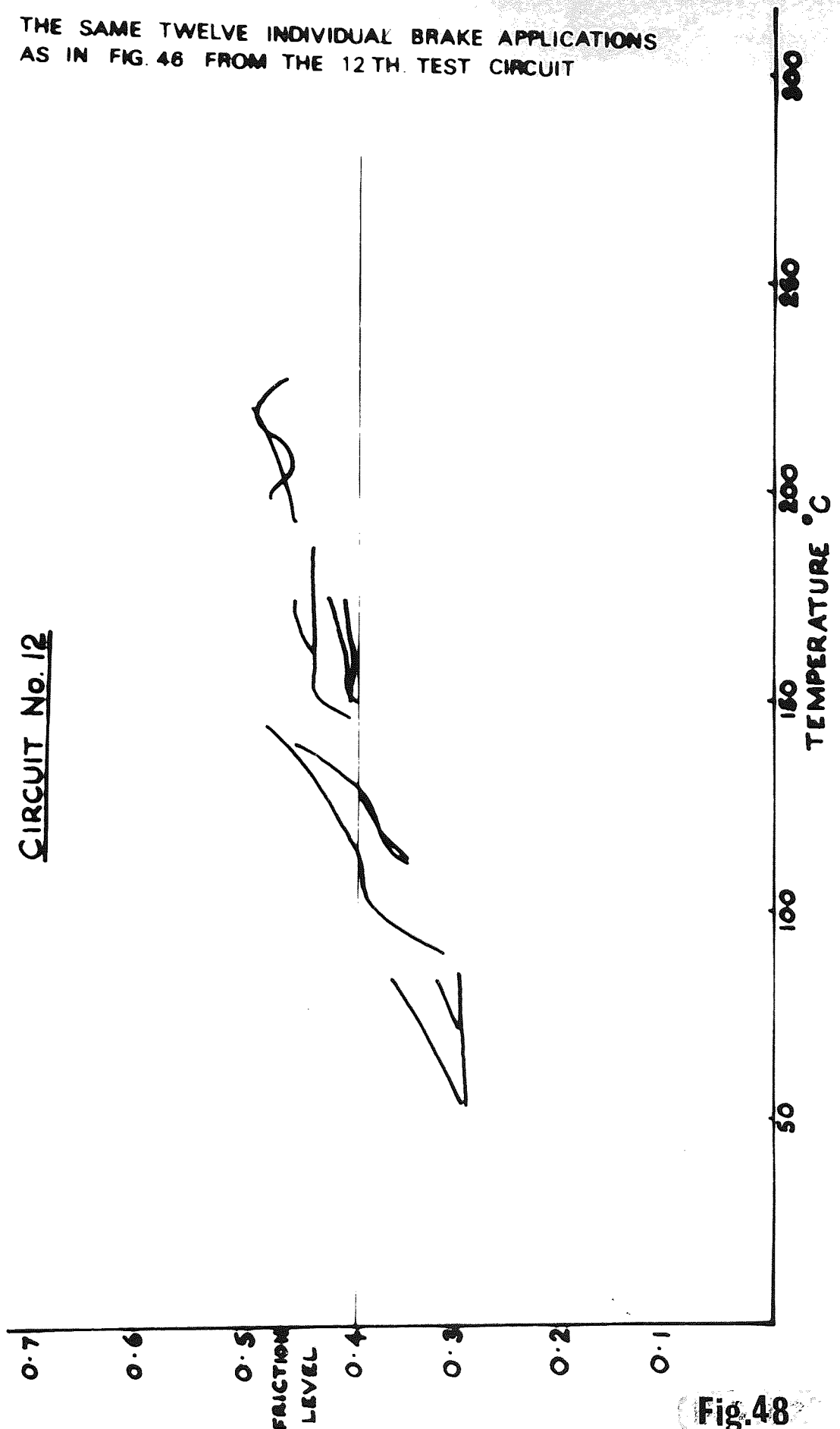

Fig. 48

TEMPERATURE °C

Fig. 48

FRONT BRAKE TEMPERATURES WITH NIS-FANCOILED DISCS

ROAD CIRCUIT DISC TEMPERATURE PROFILES
ON ORIGINAL COMPLAINT DISCS

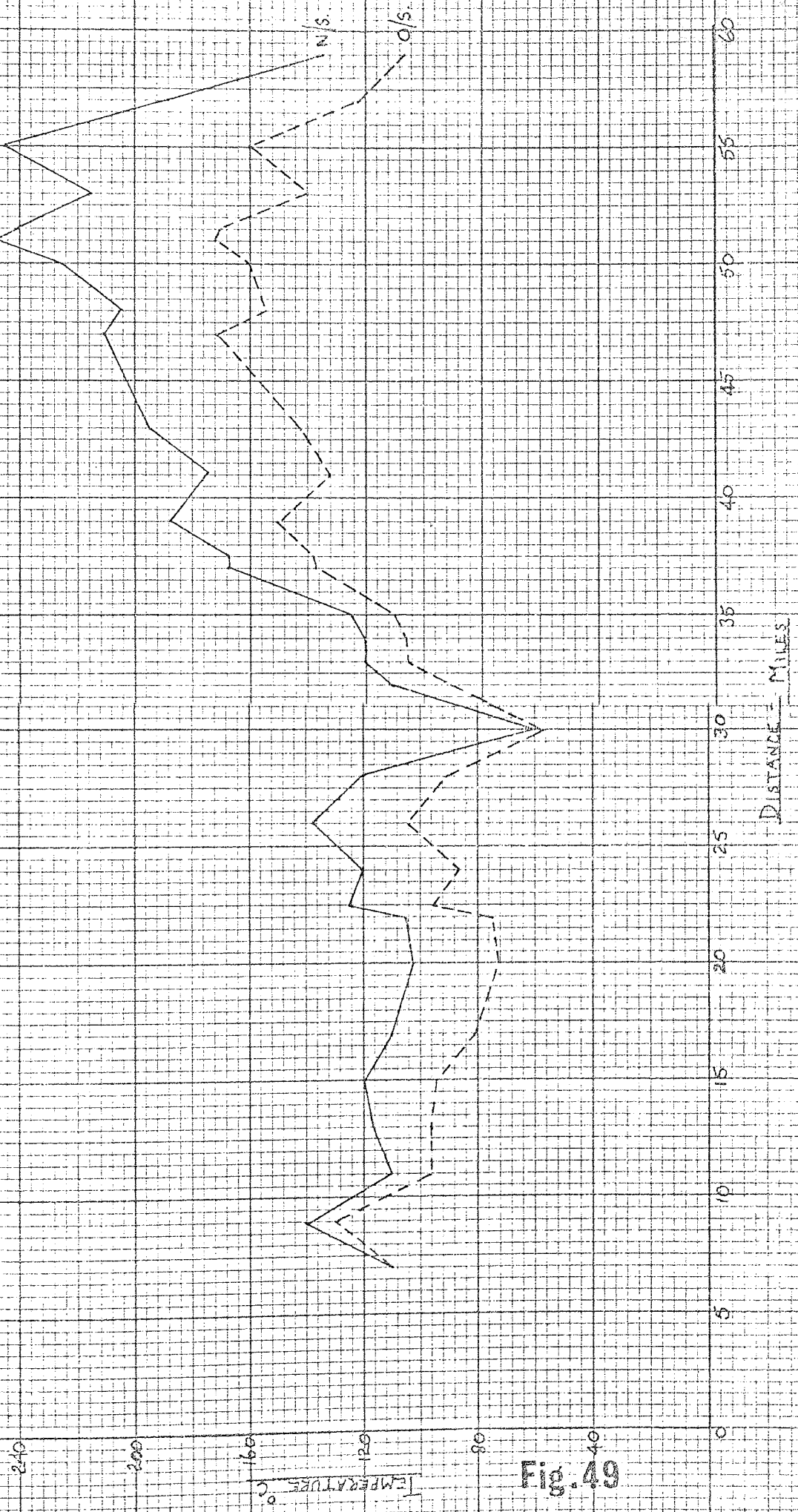
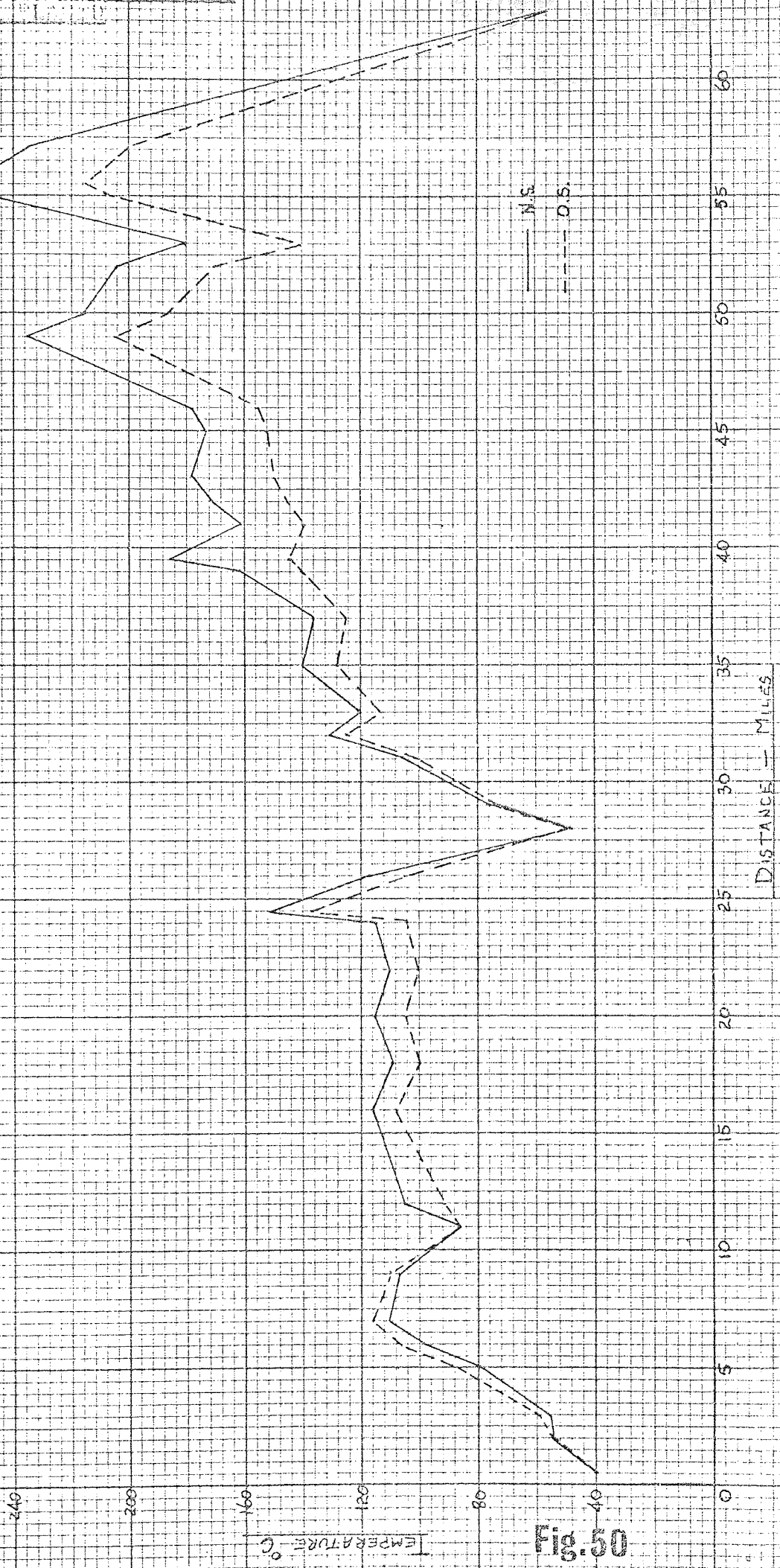

Fig. 49

ROAD CIRCUIT DISC TEMPERATURE PROFILES
WITH NEAR-SIDE DISC REPLACED BY HALBERGER DISC



— N.S.
--- O.S.

Fig. 50

ROAD CIRCUIT DISC TEMPERATURE PROFILES
WITH BOTH ORIGINAL DISCS REPLACED BY HALBERGER DISCS

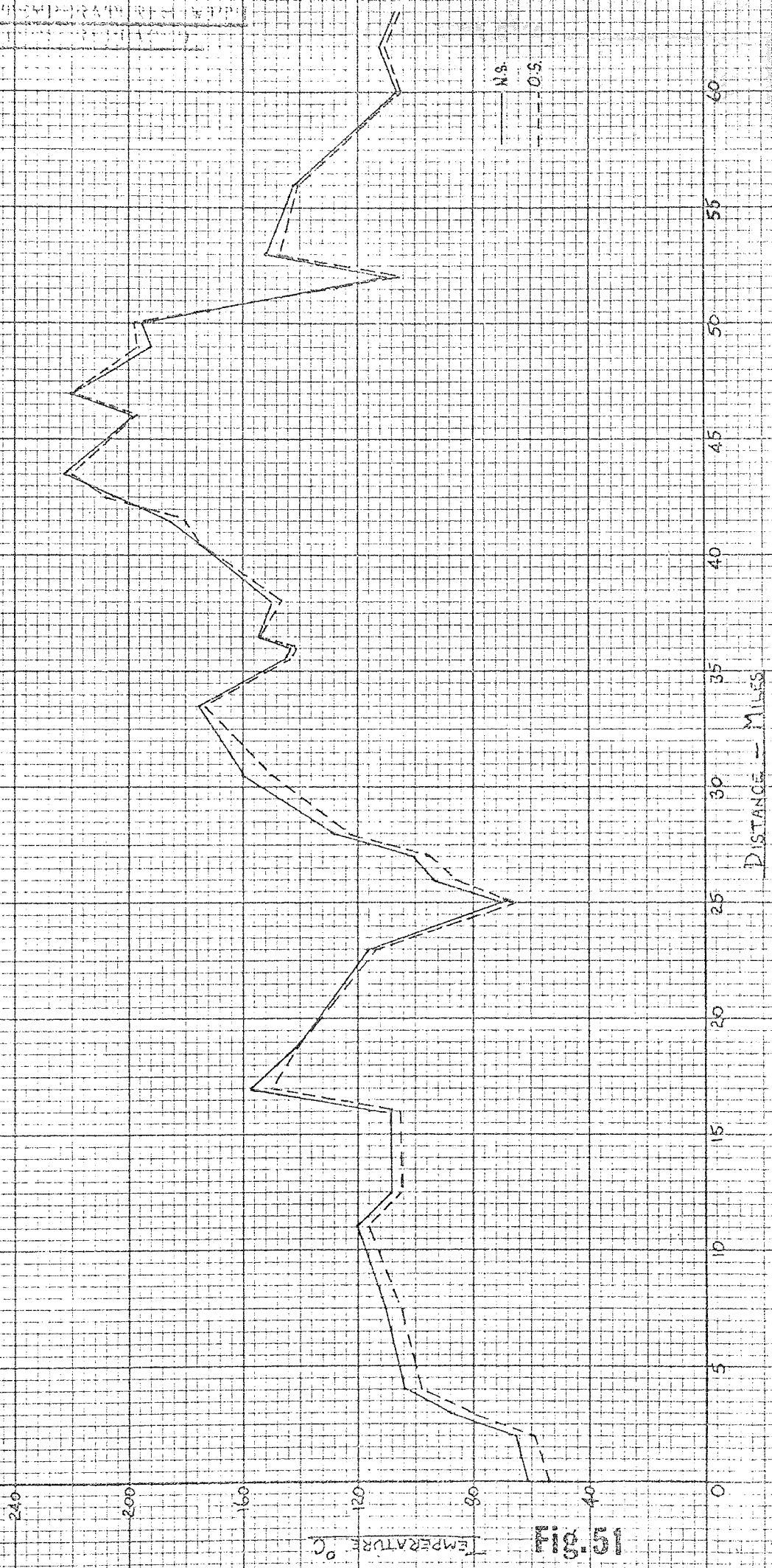

Fig. 51

μ /temperature graph for near side front disc.

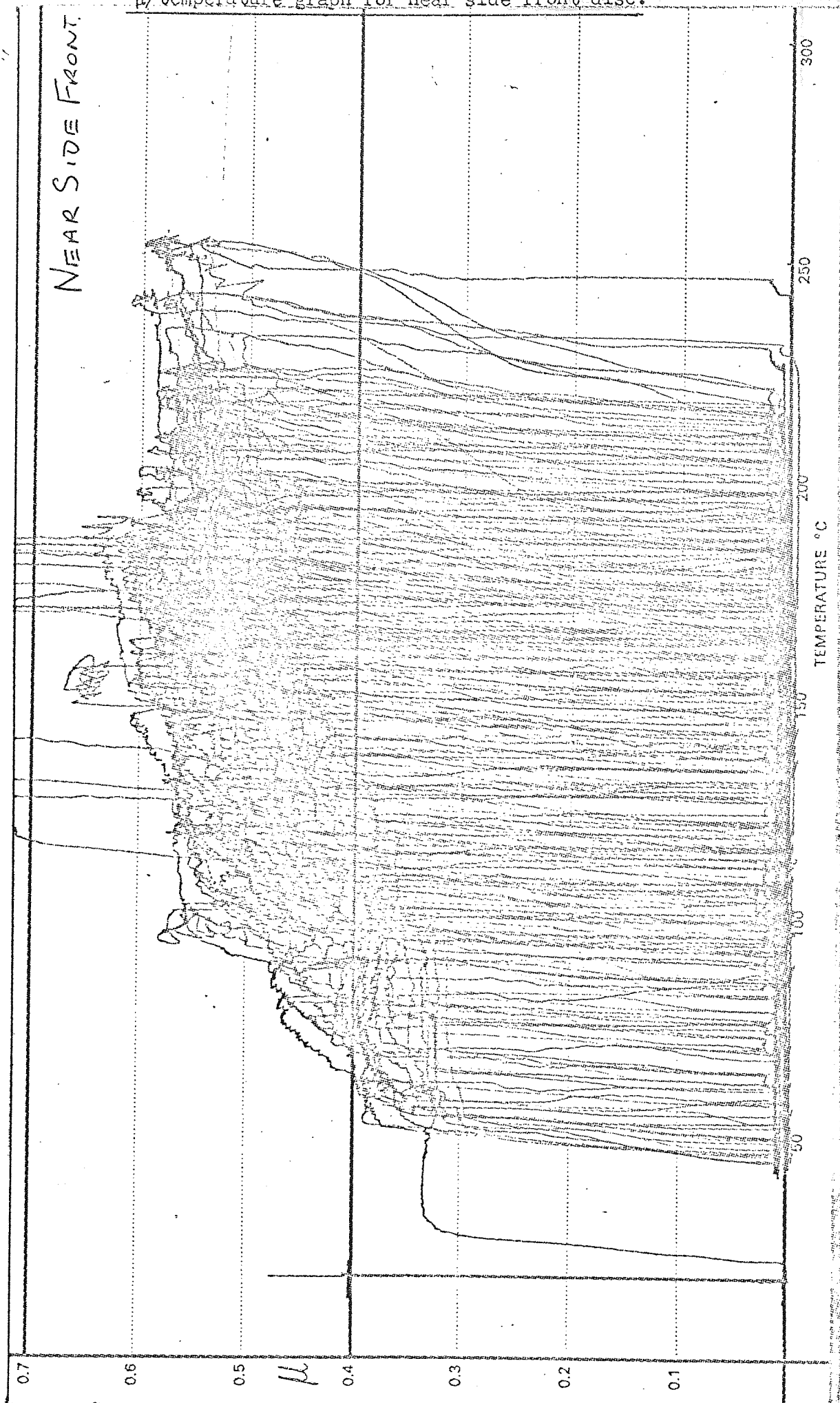

Fig. 52

μ /temperature graph for off side front disc

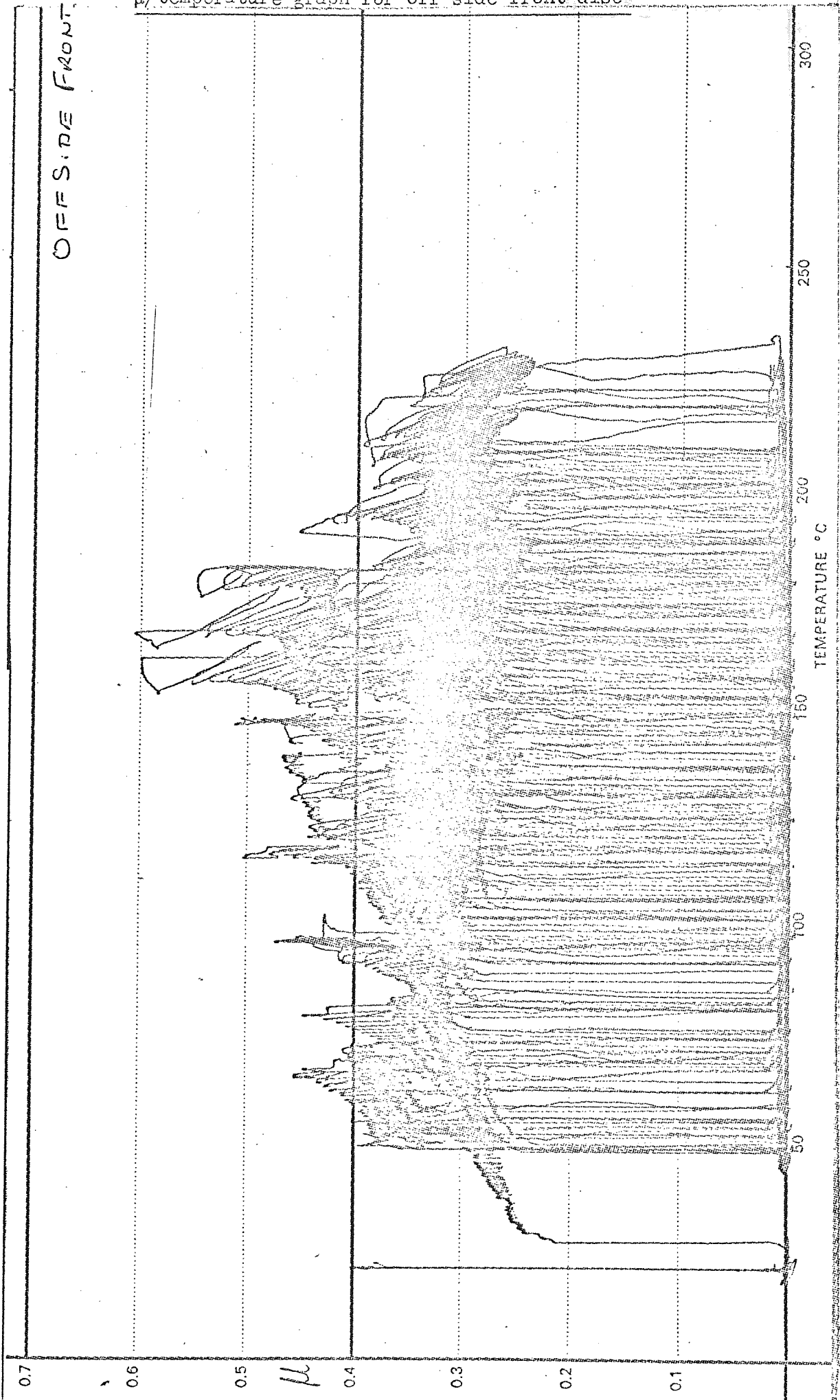

Fig. 53

μ /temperature graph for first replacement disc

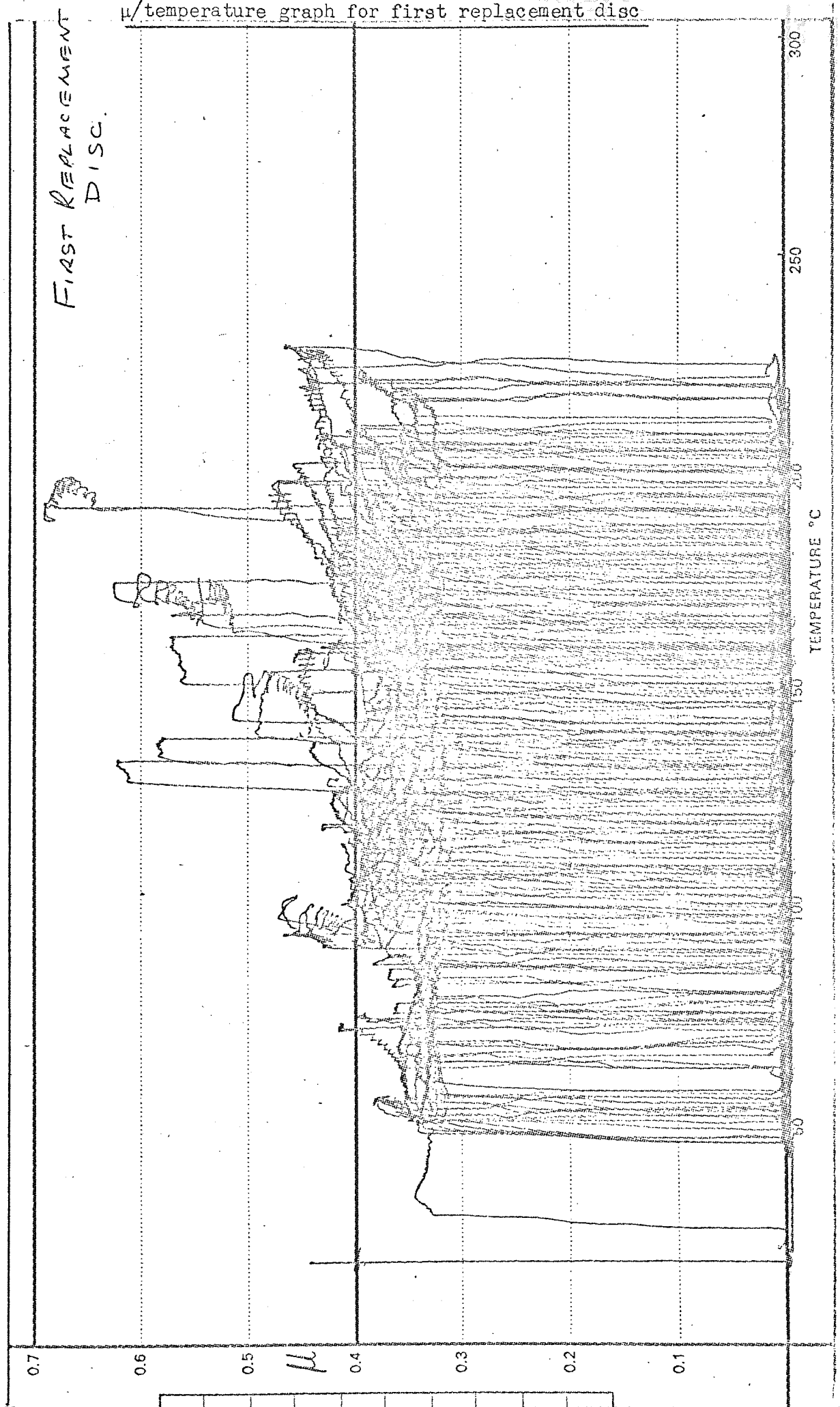

Fig. 54

SECOND REPLACEMENT
DISC.

μ /temperature graph for second replacement disc

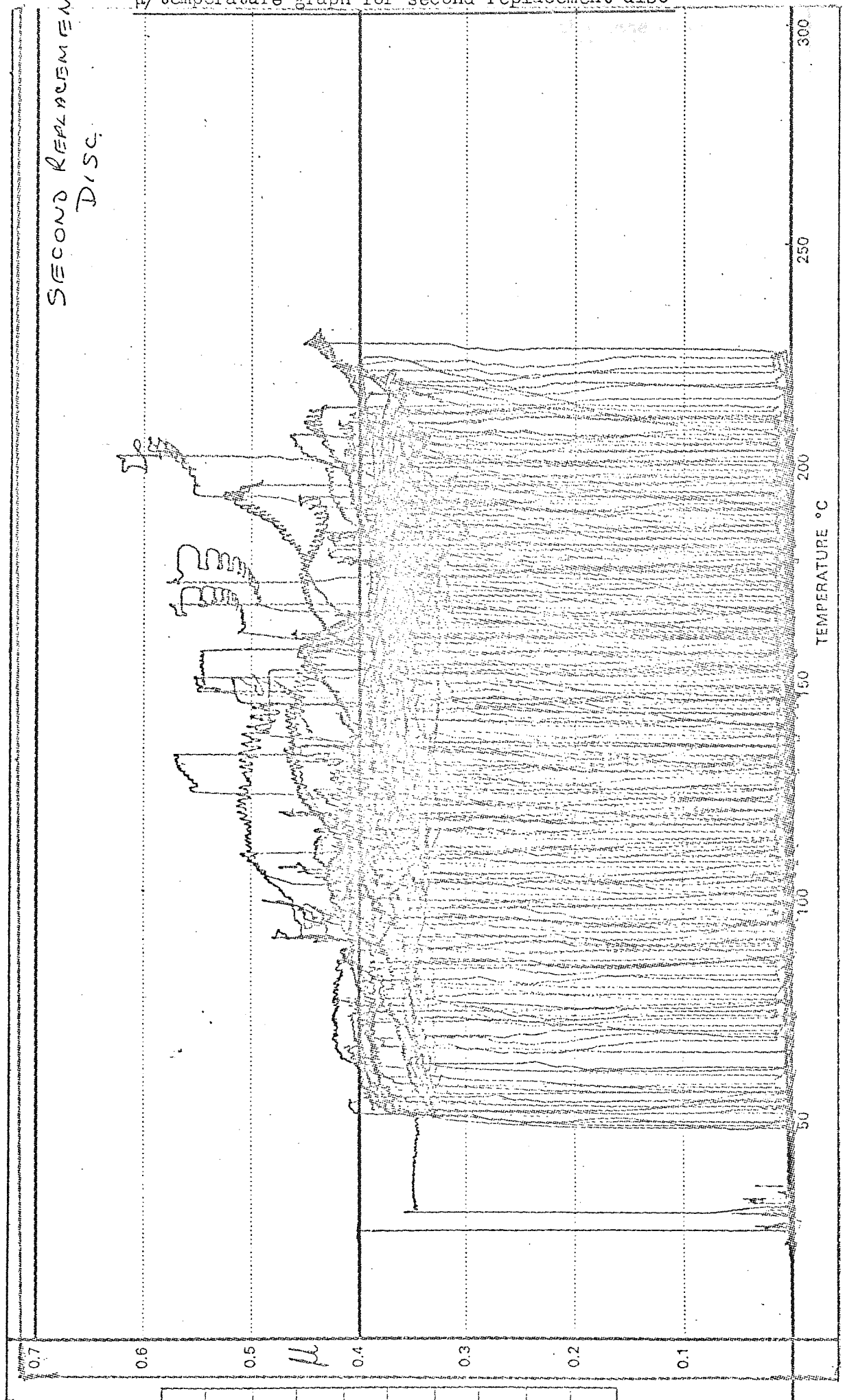
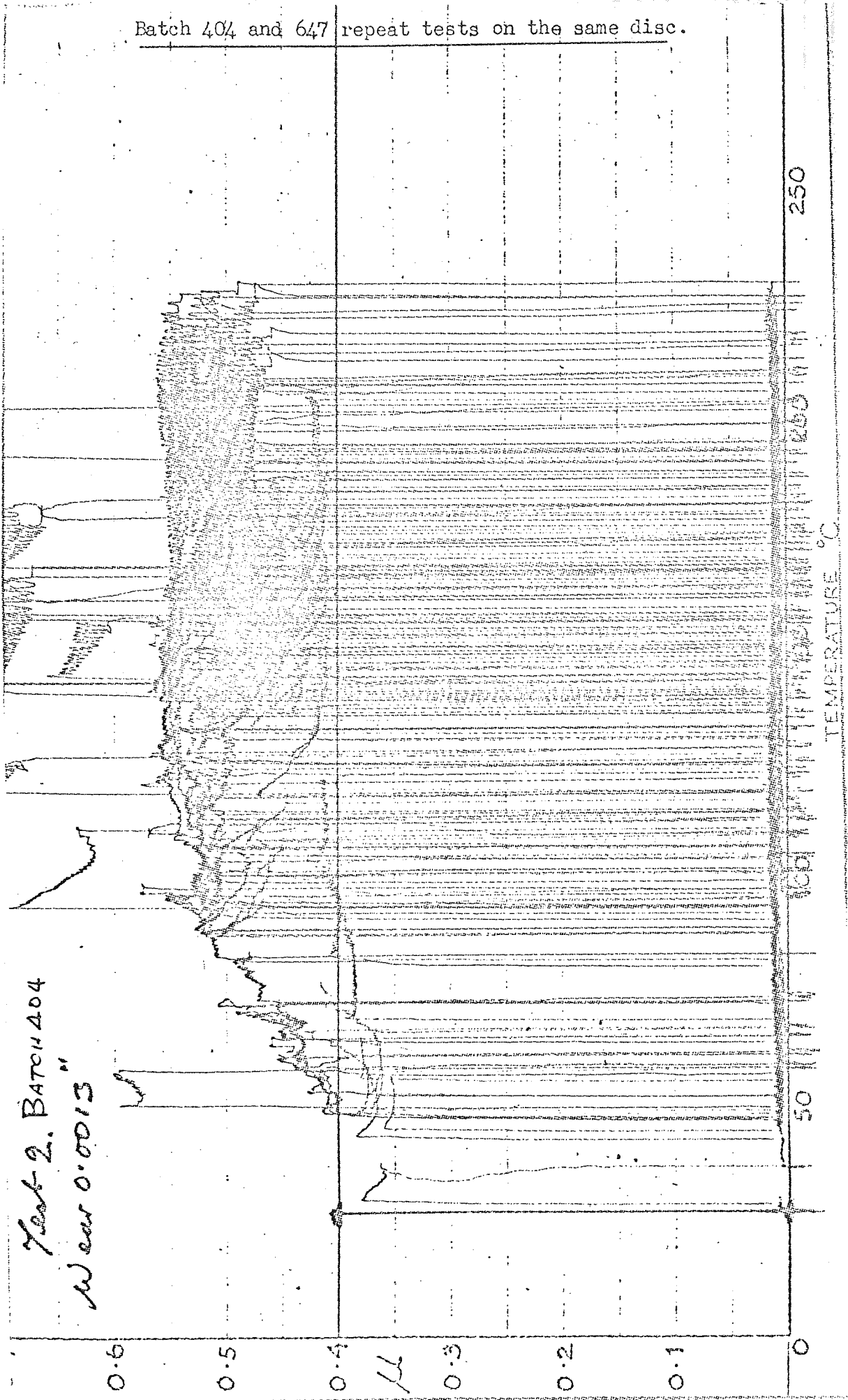

Fig. 55

Batch 404 and 647 repeat tests on the same disc.



Test 2. BATCH 404
Wear 0.0013"

Fig. 56

See Fig. 56

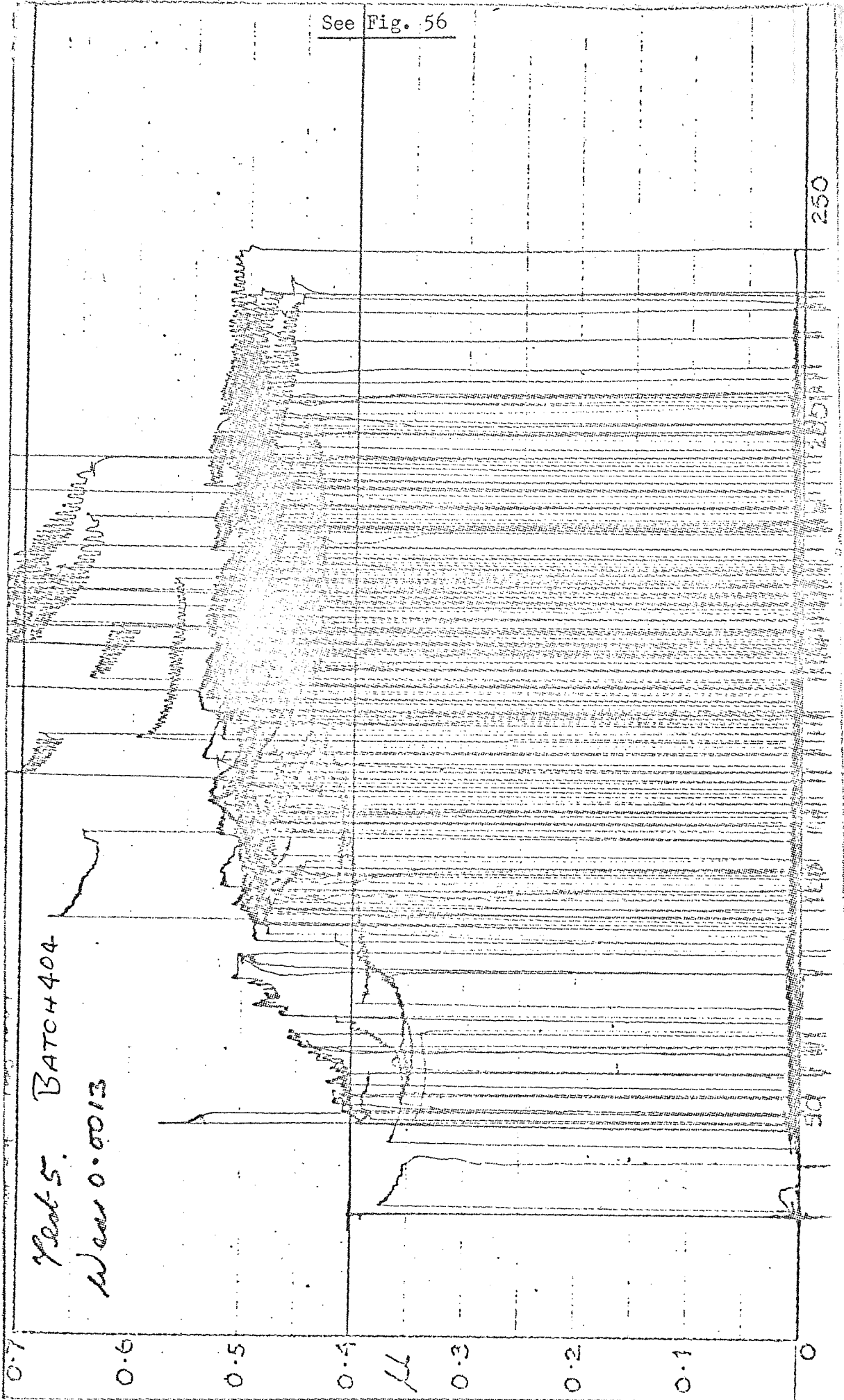

Sheet 5. BATCH 404
Wear 0.0013

250

Fig. 57

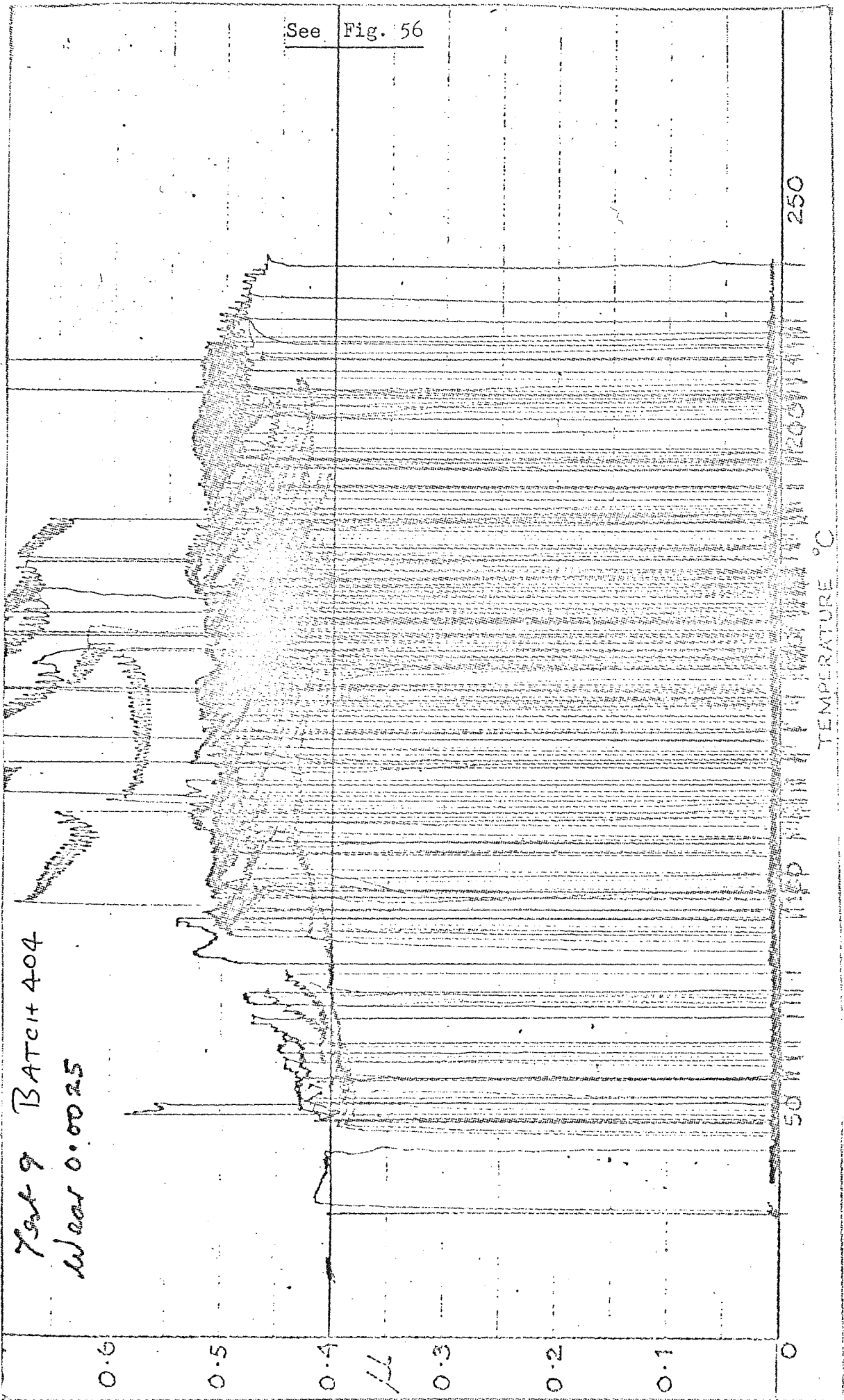

Test 9 BATEI+404
Wear 0.0025

Fig. 58

See Fig. 56.

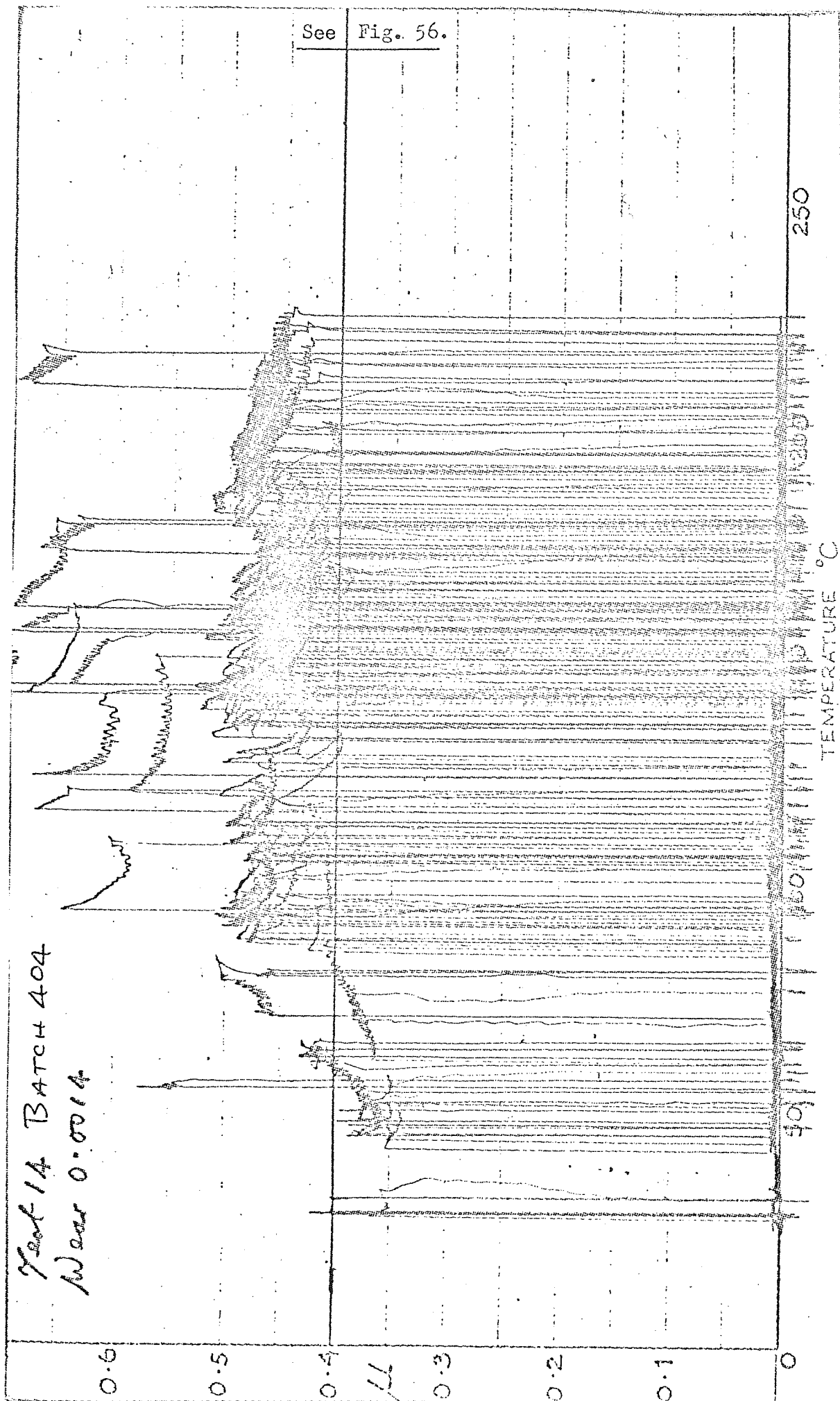

Test 1A BATCH 404
Wear 0.0014

Fig. 59

See Fig. 56.

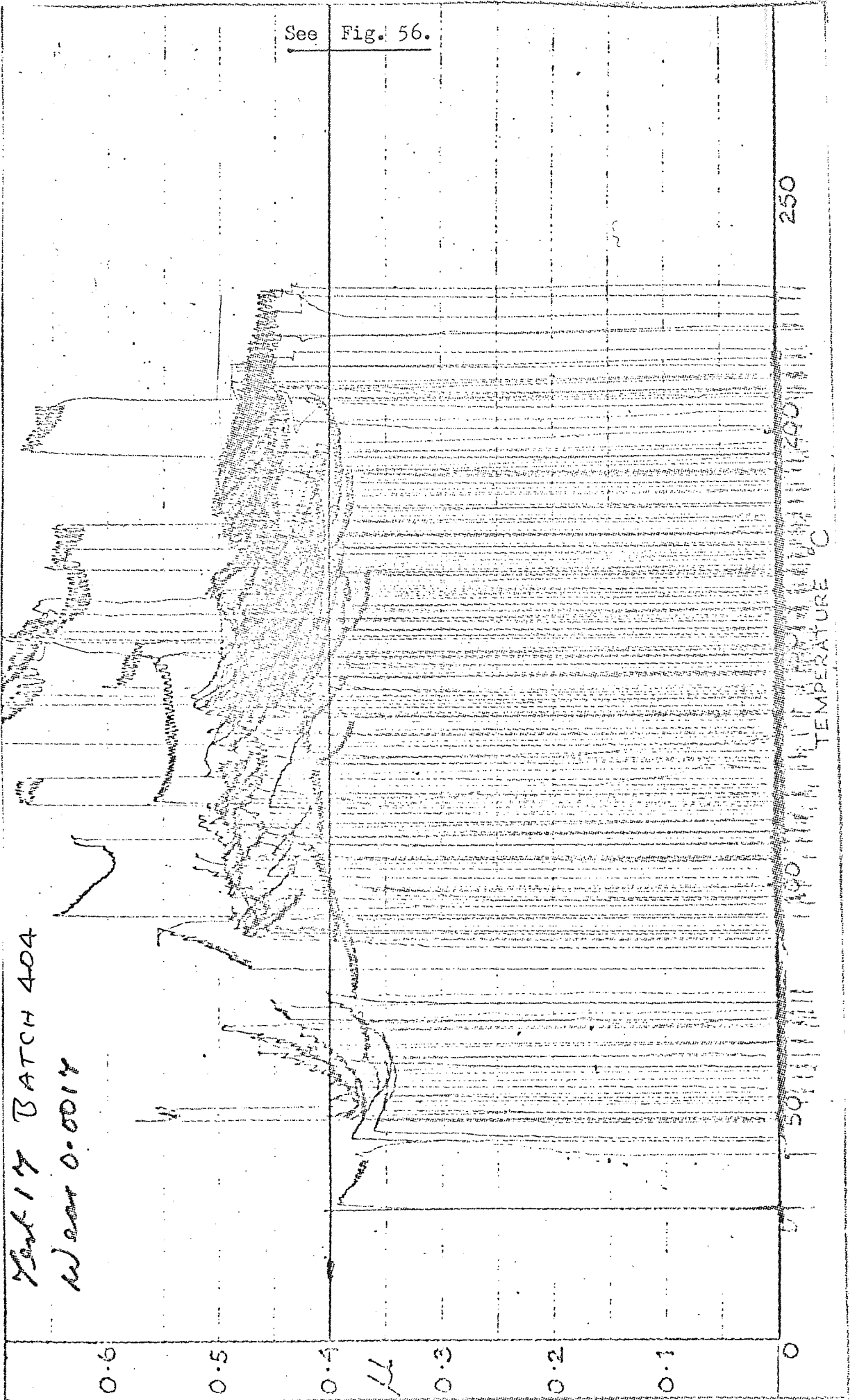

Fig. 60

See Fig. 56.

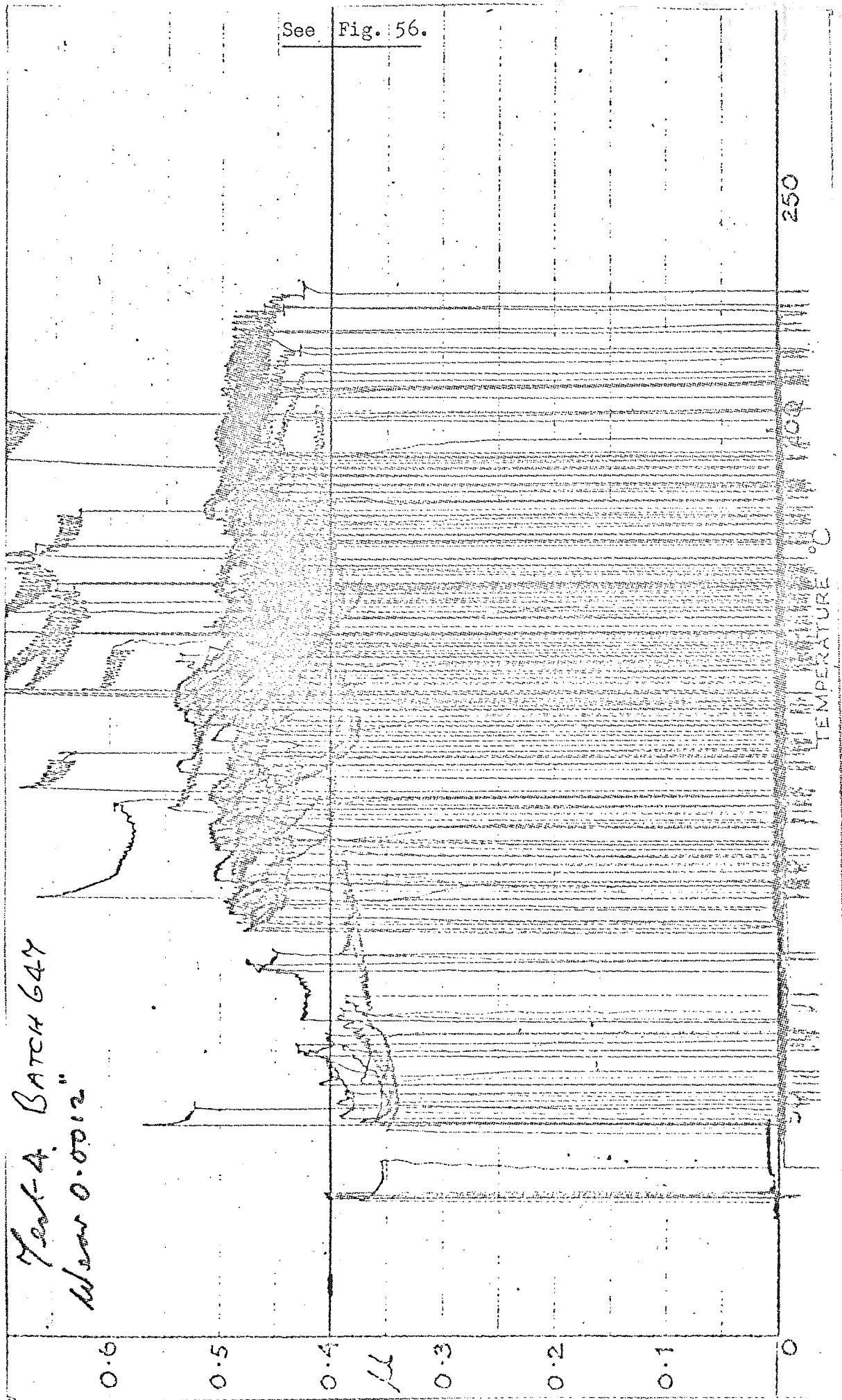
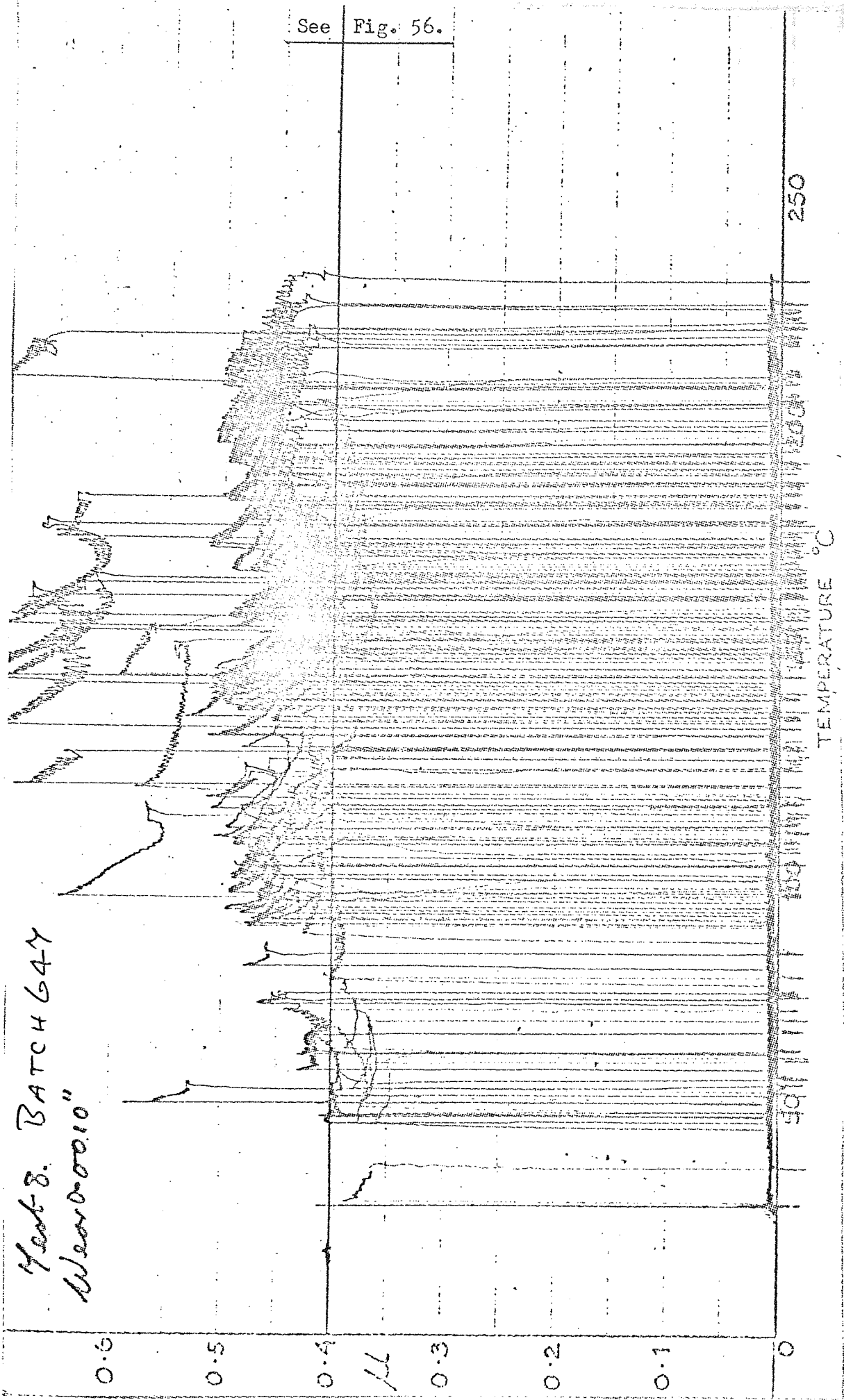

Fig. 61

See Fig. 56.



Heat 8. BATCH 64Y
Wear 0.0010"

Fig. 62

See Fig. 56.

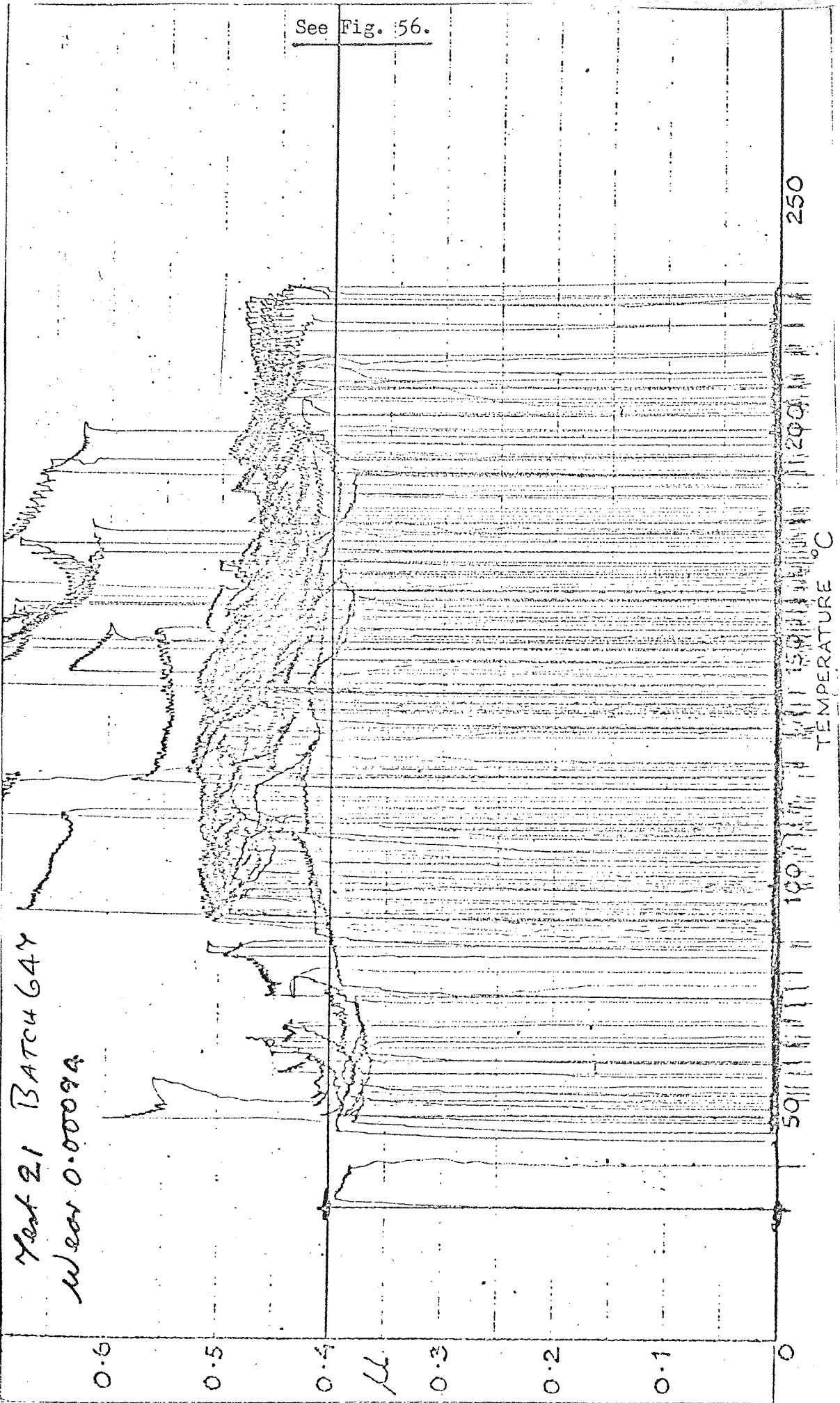

Test 21 BATCH 64Y
Wear 0.0009A

250

TEMPERATURE °C

1991

5911

Fig. 63

See Fig. 56.

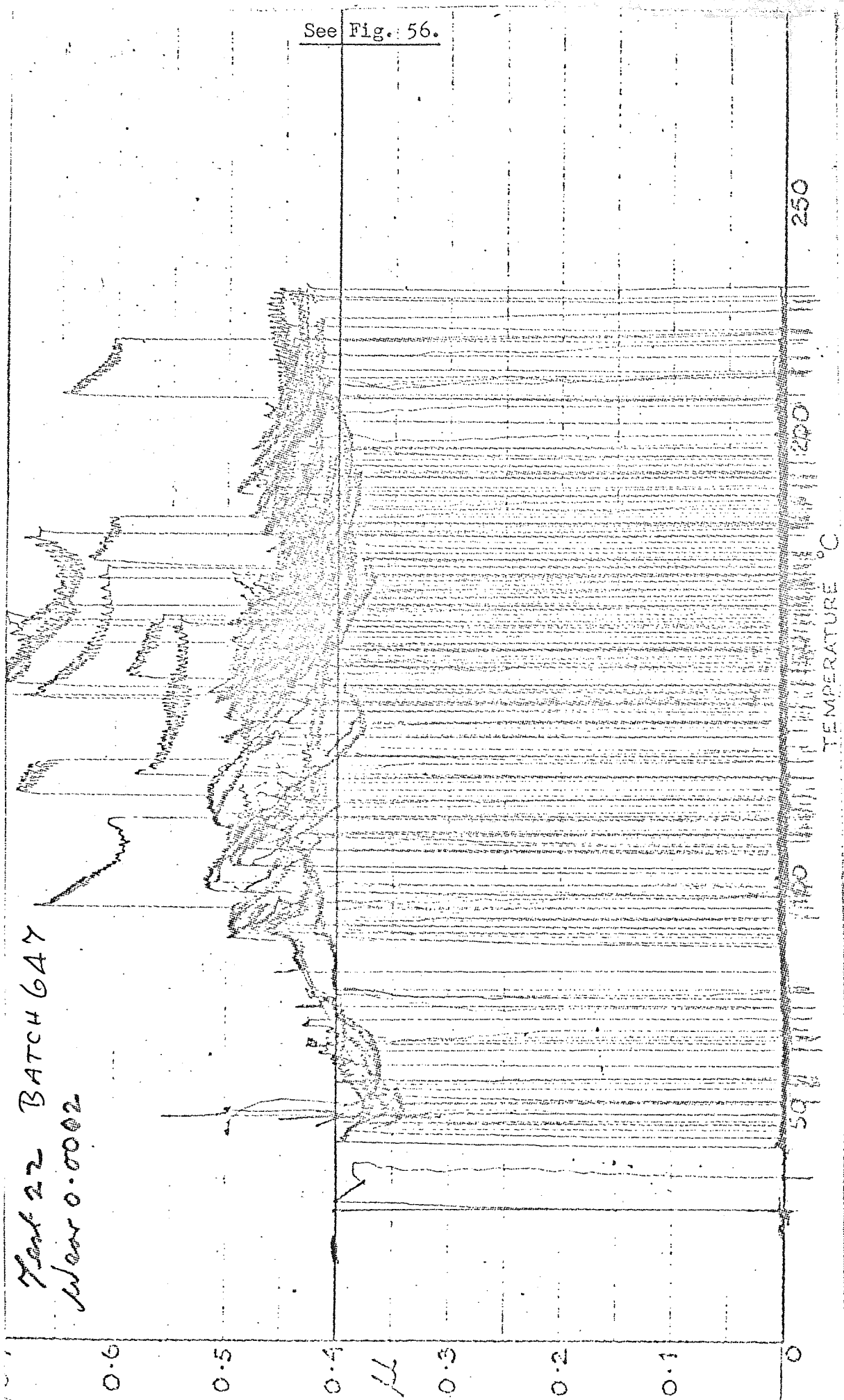

Test 22 BATCH 64Y
Wear 0.0002

Fig. 64

See Fig. 56.

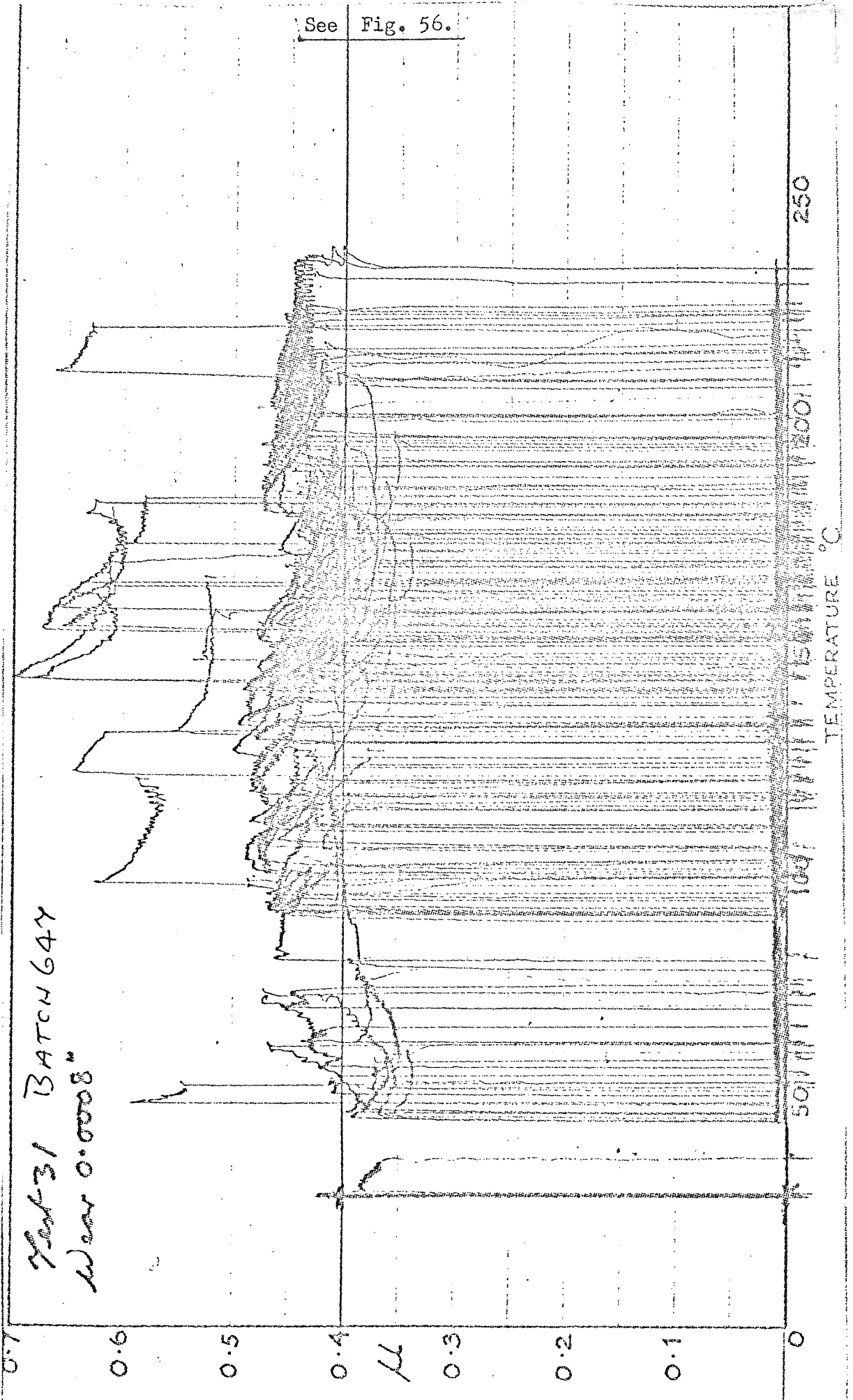

Fig. 65

See Fig. 56.

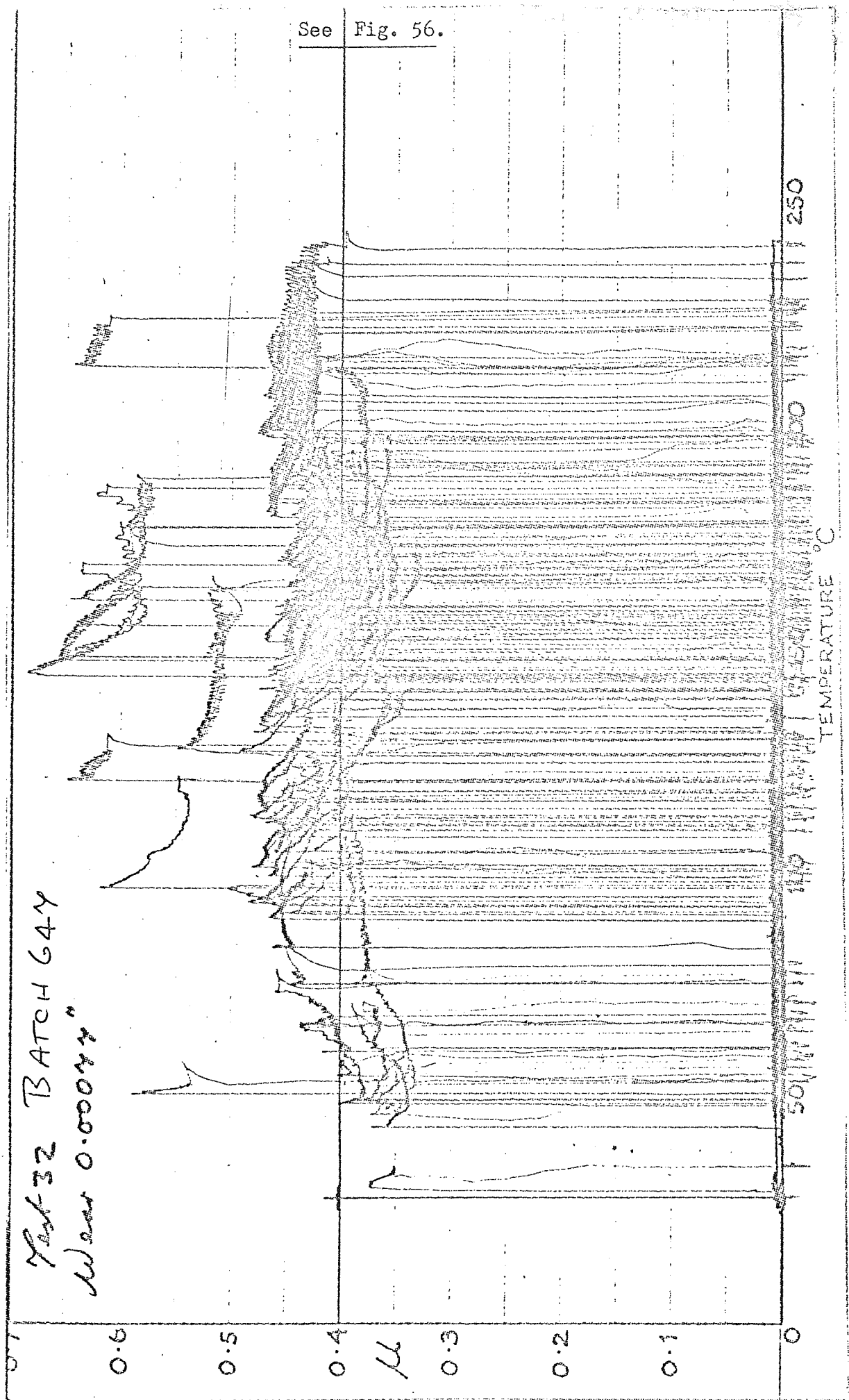

Fig. 66

Effect of small changes in composition of material.

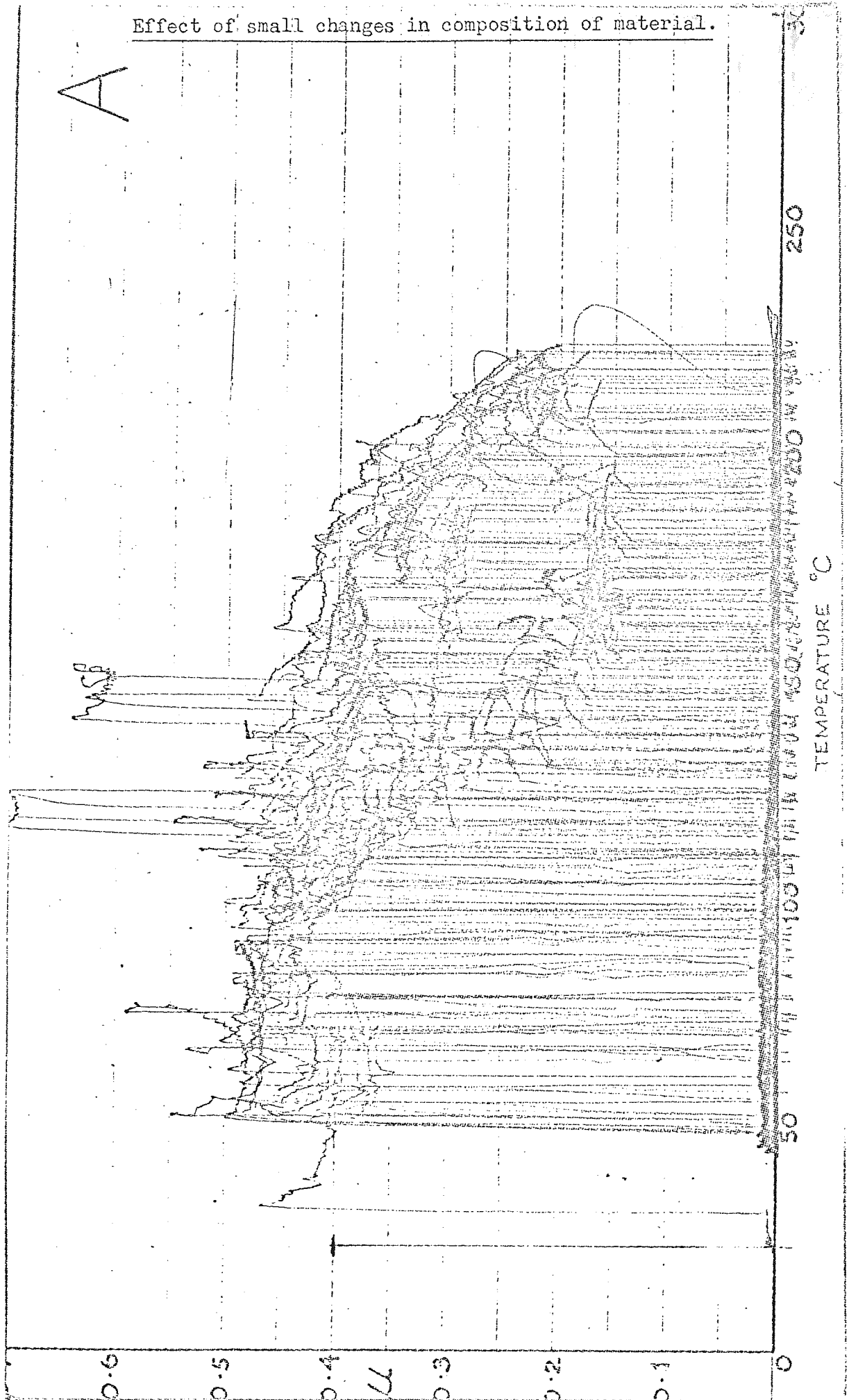

Fig.67

See Fig. 67.

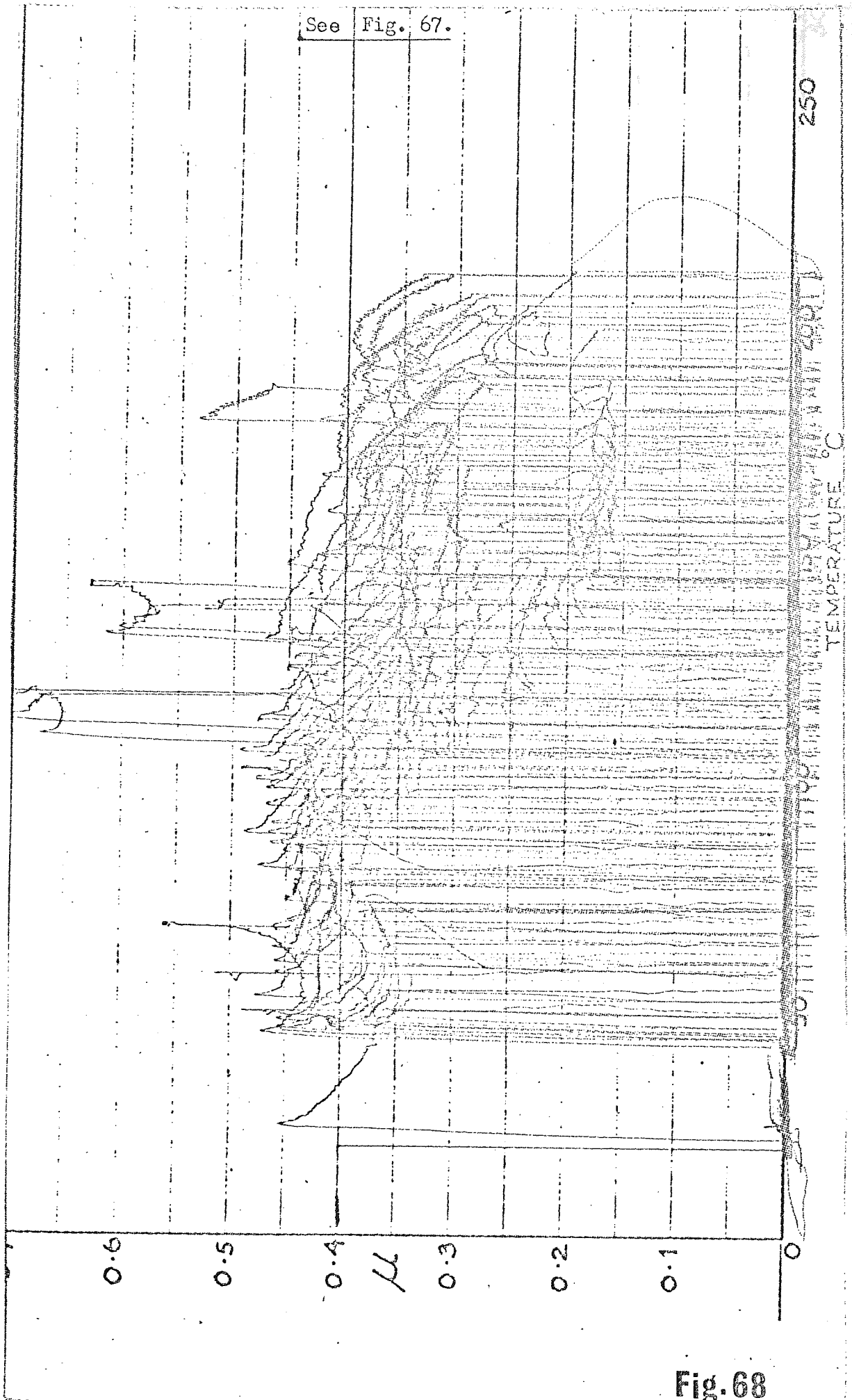

Fig. 68

See Fig. 67.

B

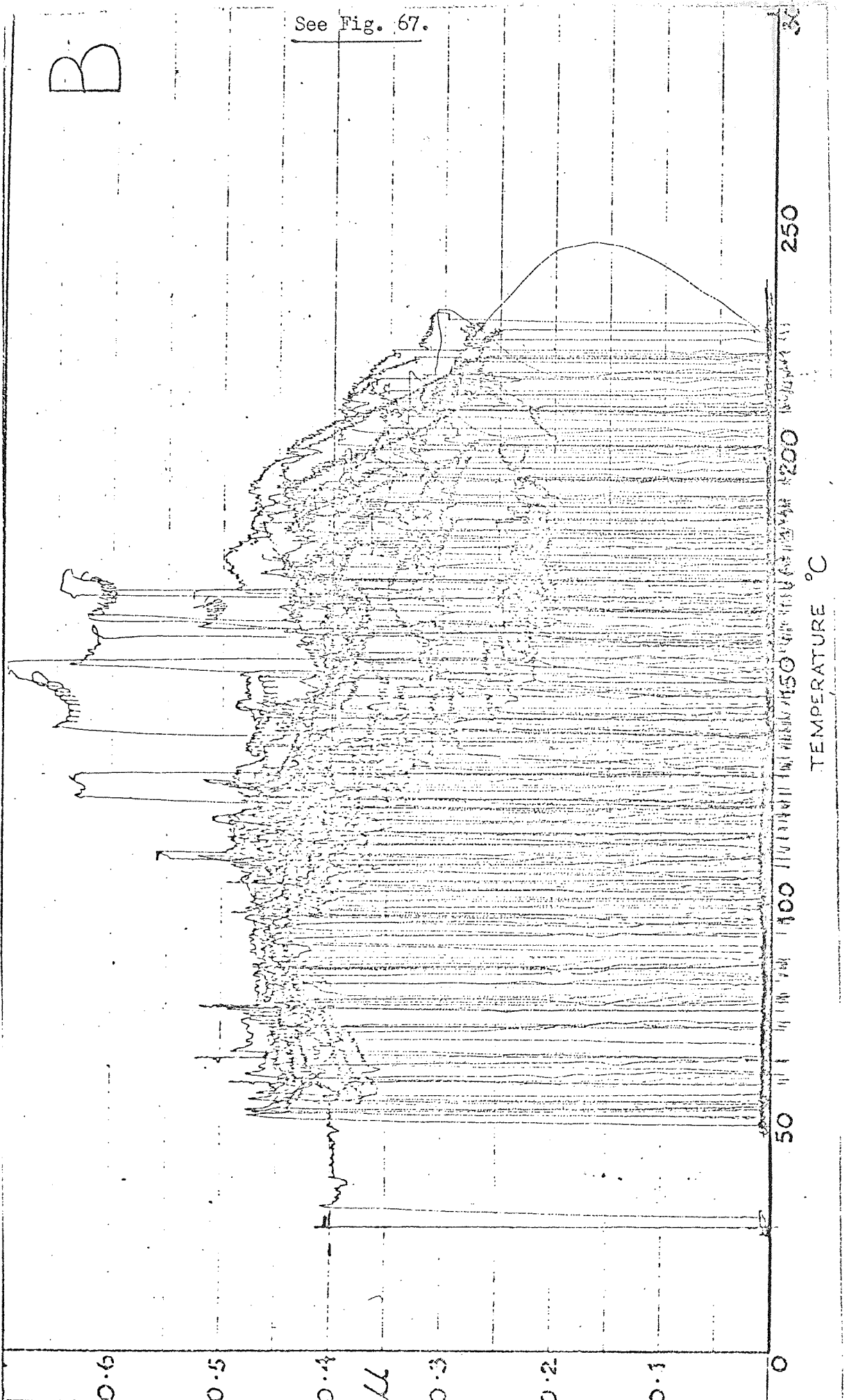

Fig. 69

See Fig. 67.

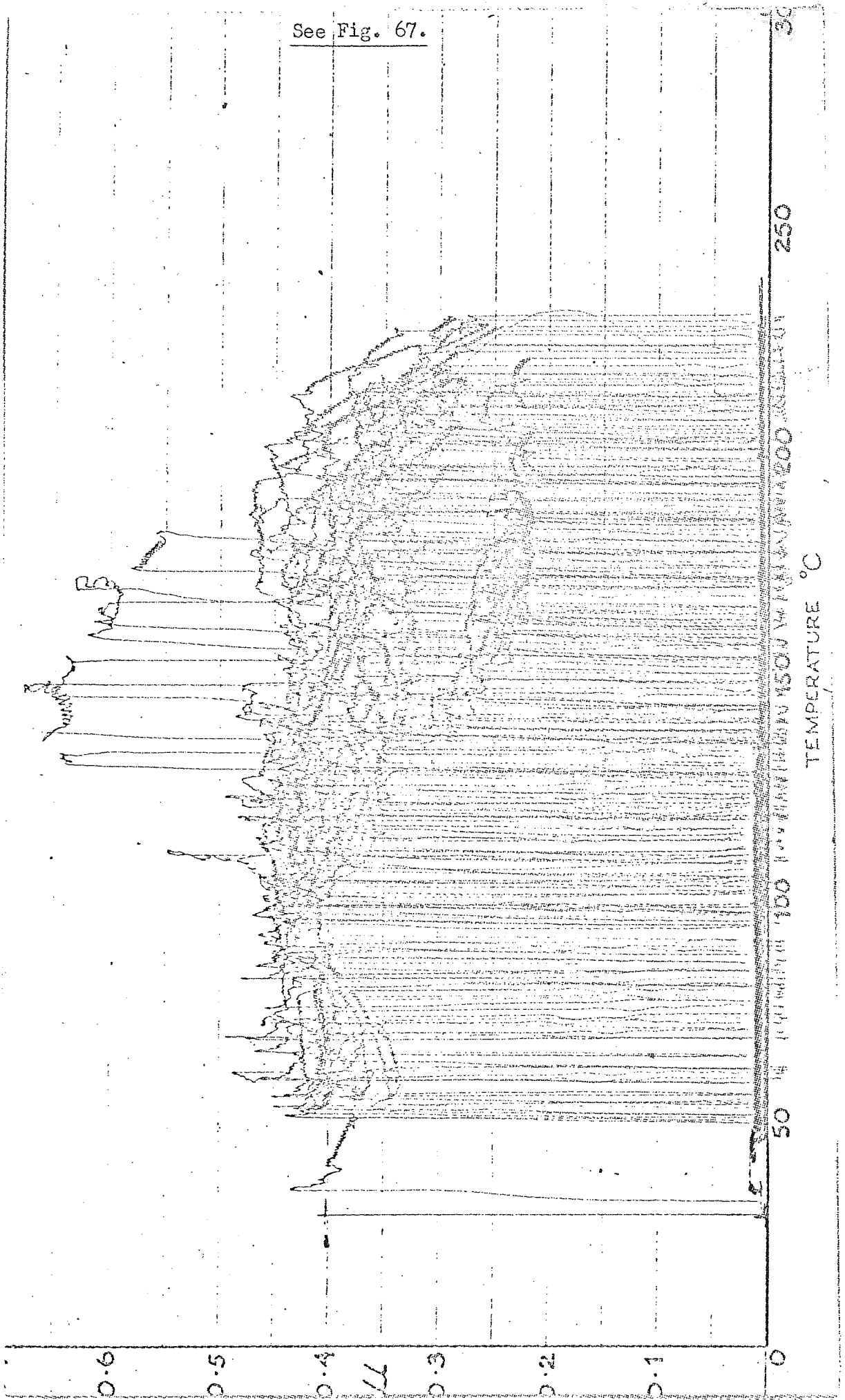

Fig.70

See Fig. 67.

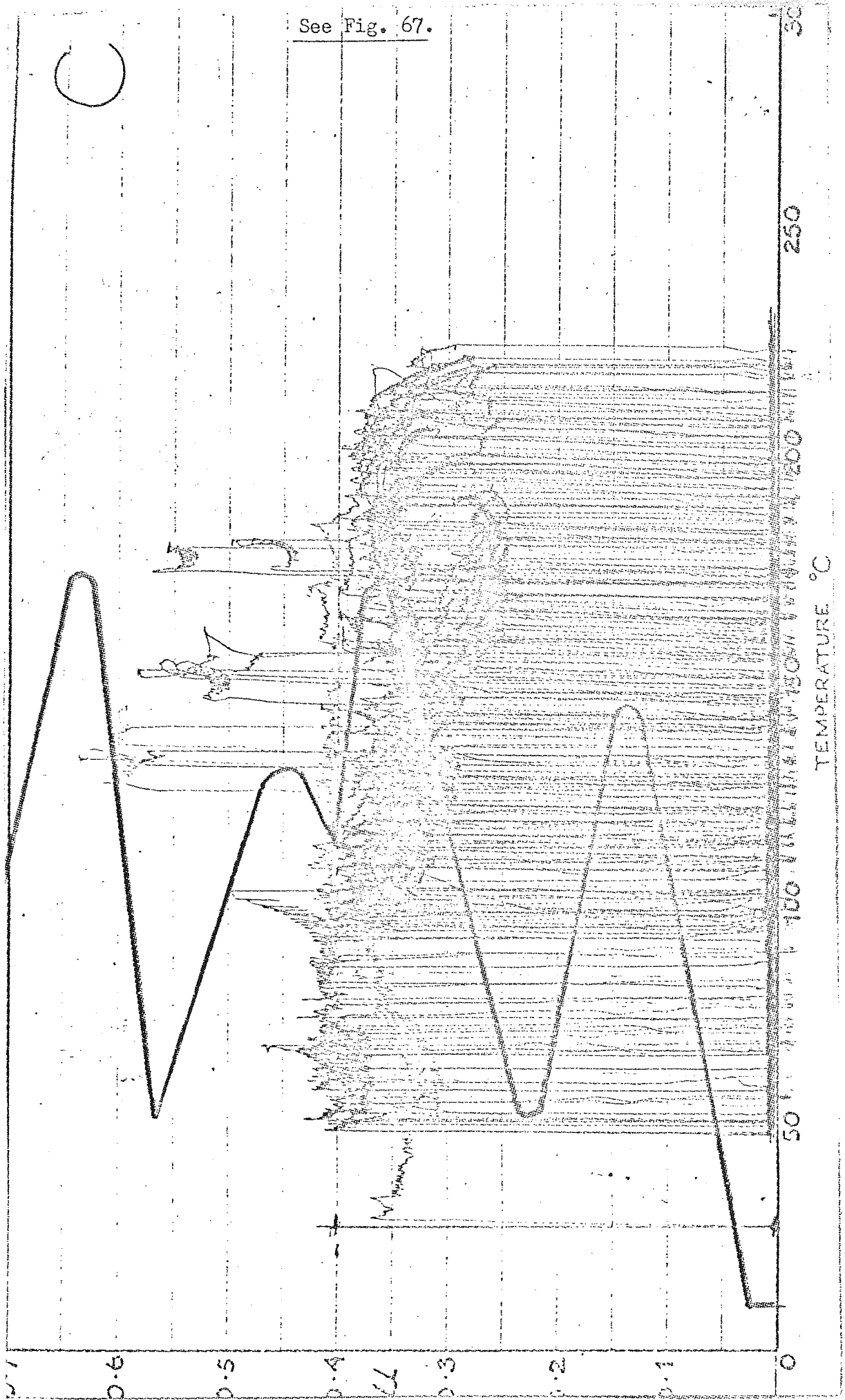

Fig. 71

See Fig. 67.

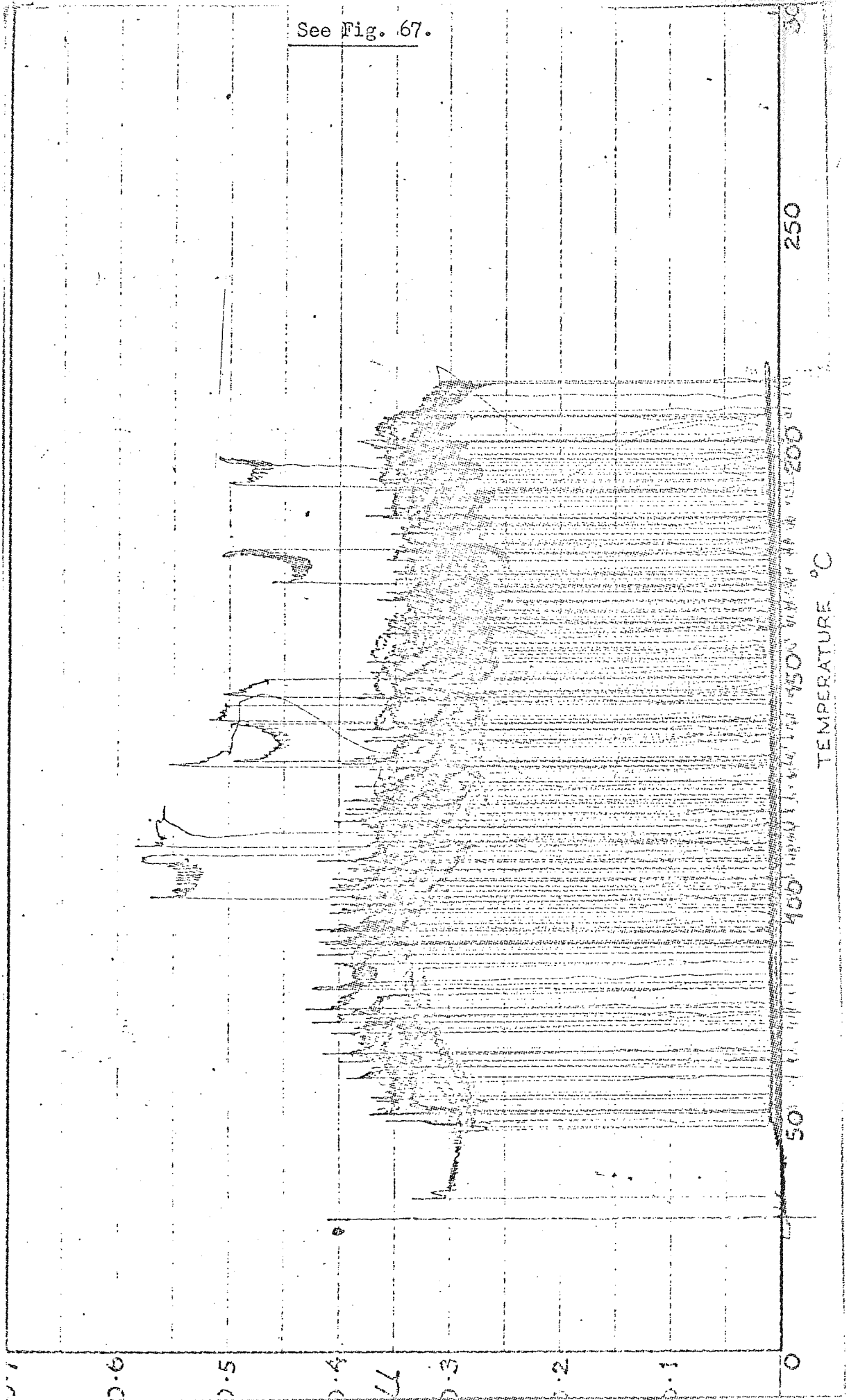
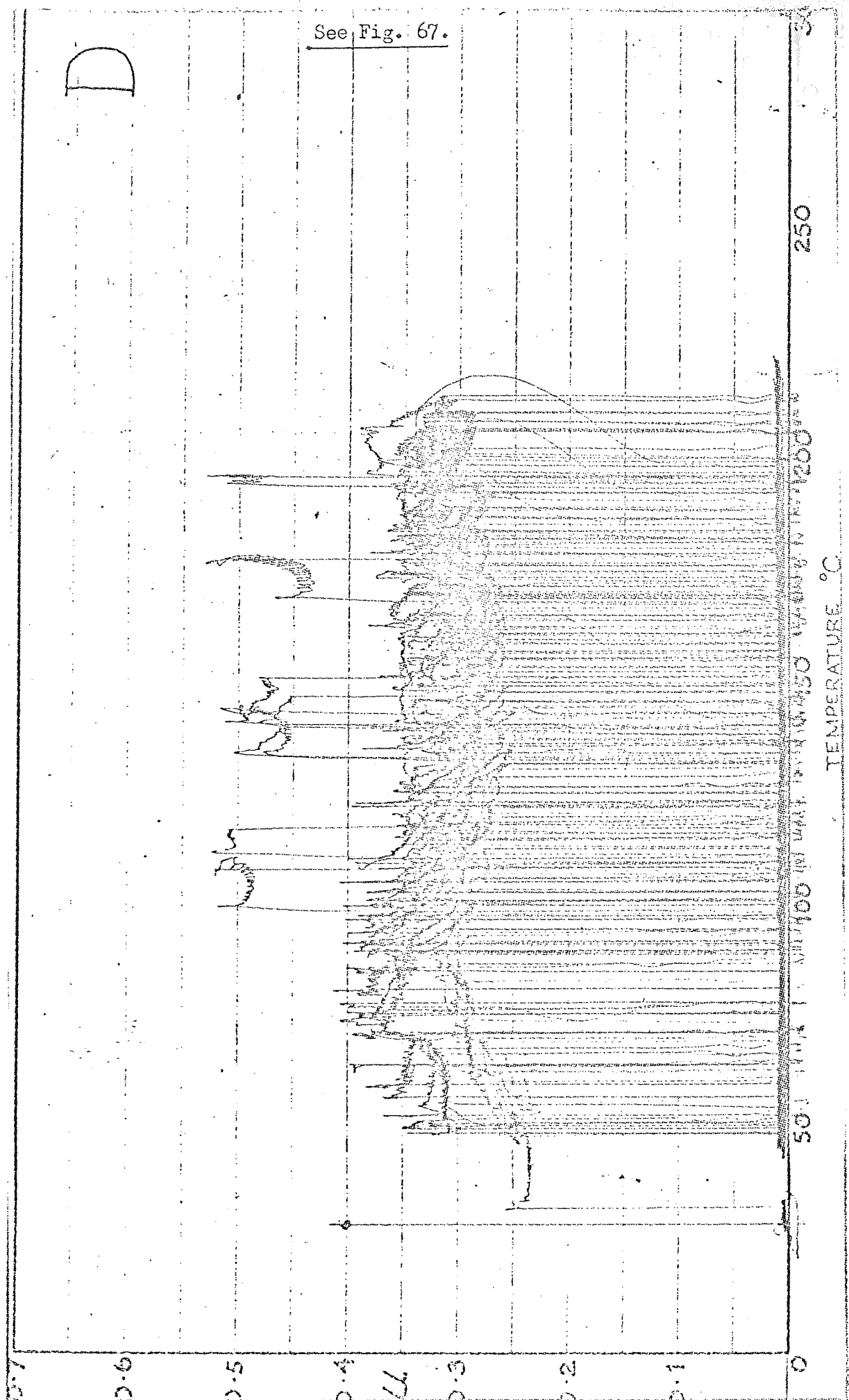

Fig. 72

See Fig. 67.

D



250

WAVELENGTH μm

TEMPERATURE °C

Fig. 73

Effect of interaction between components of composition.

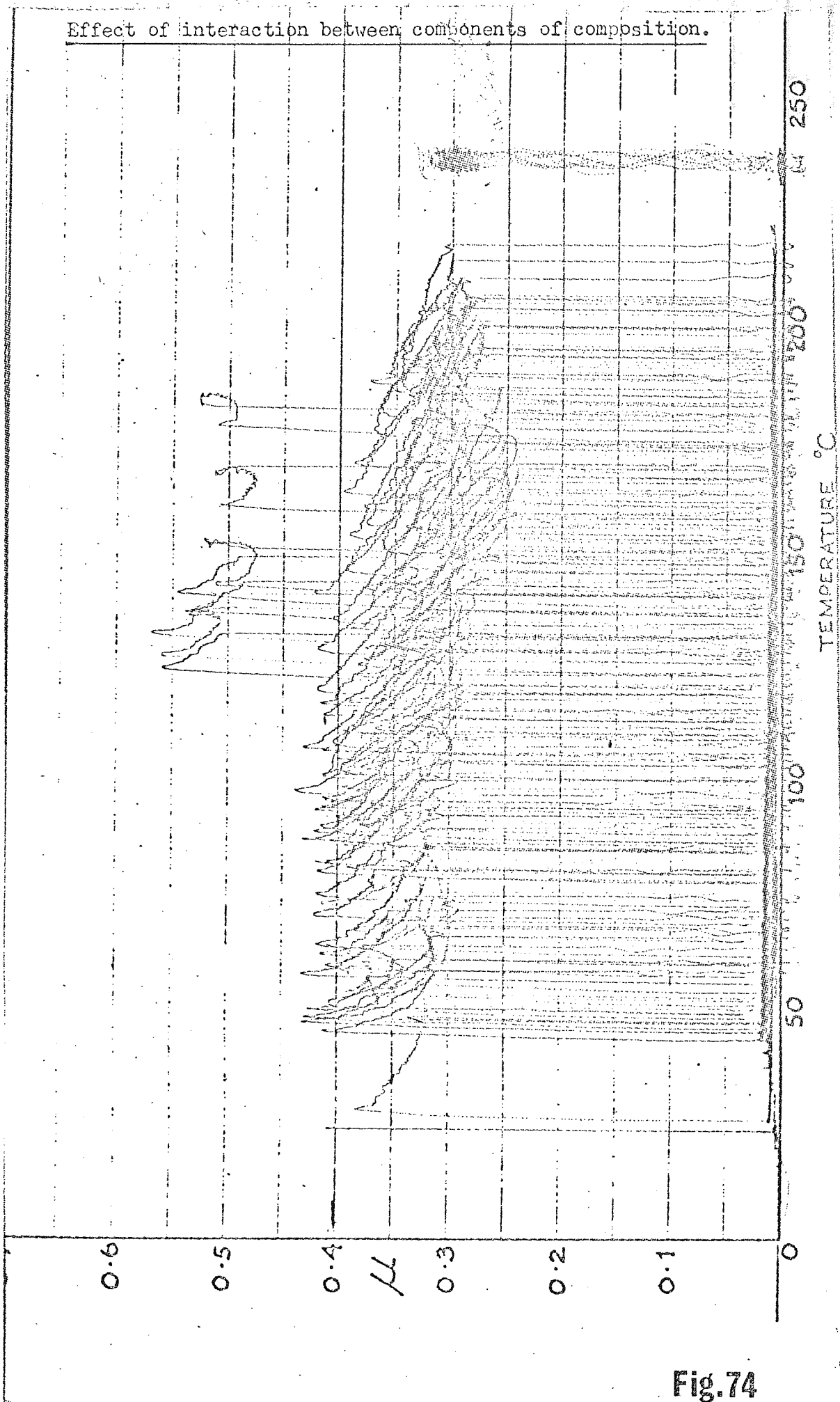
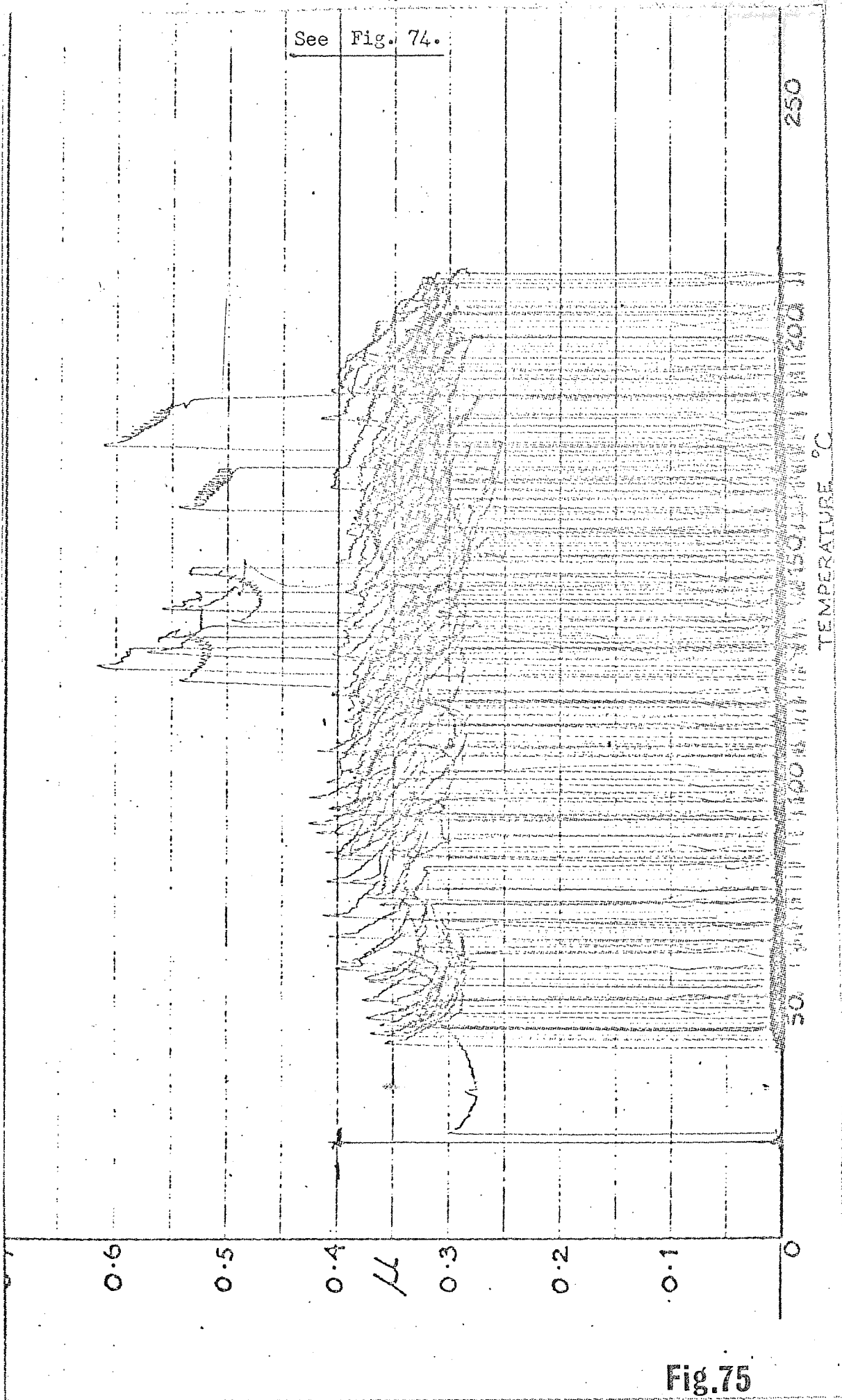

Fig.74



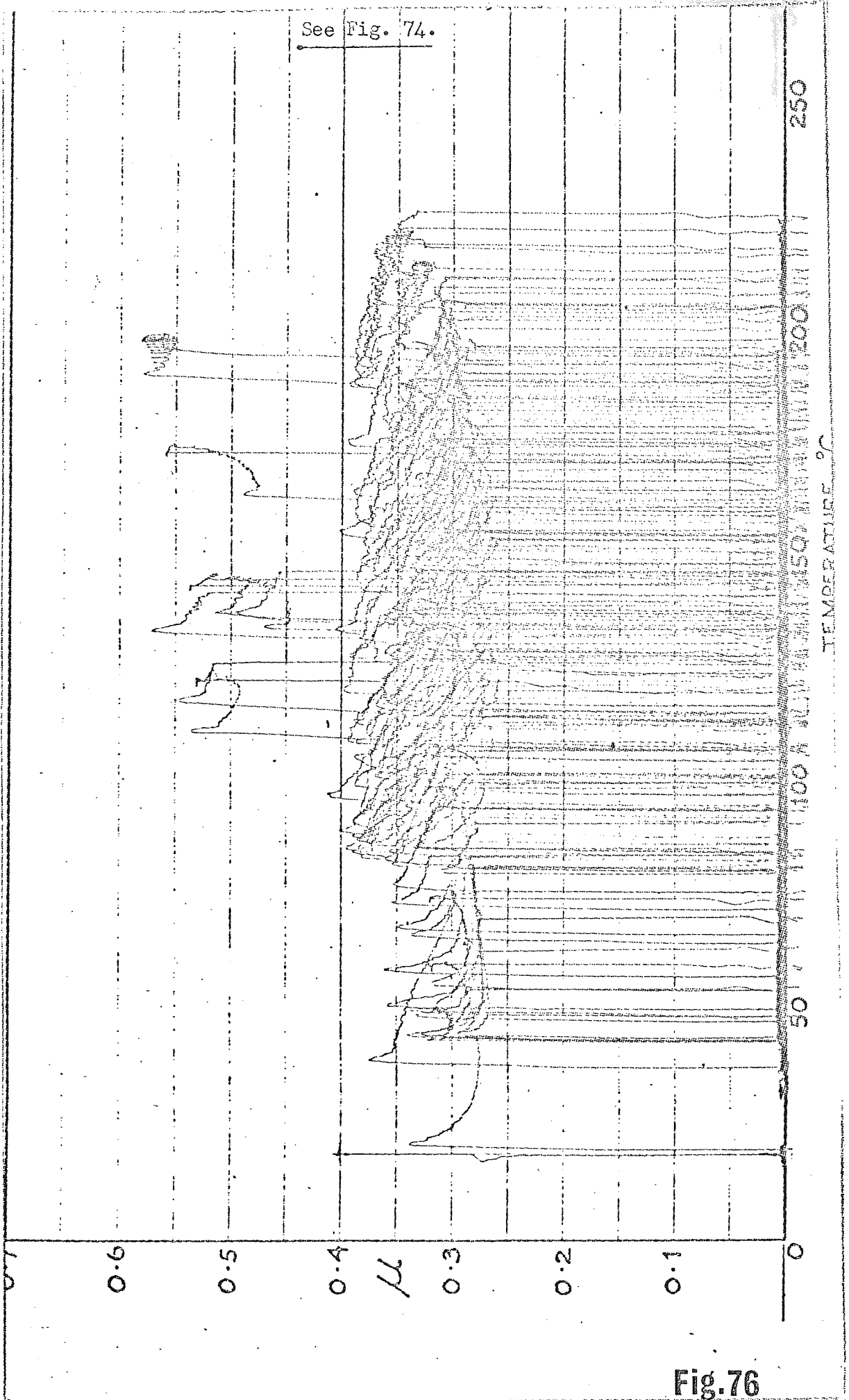
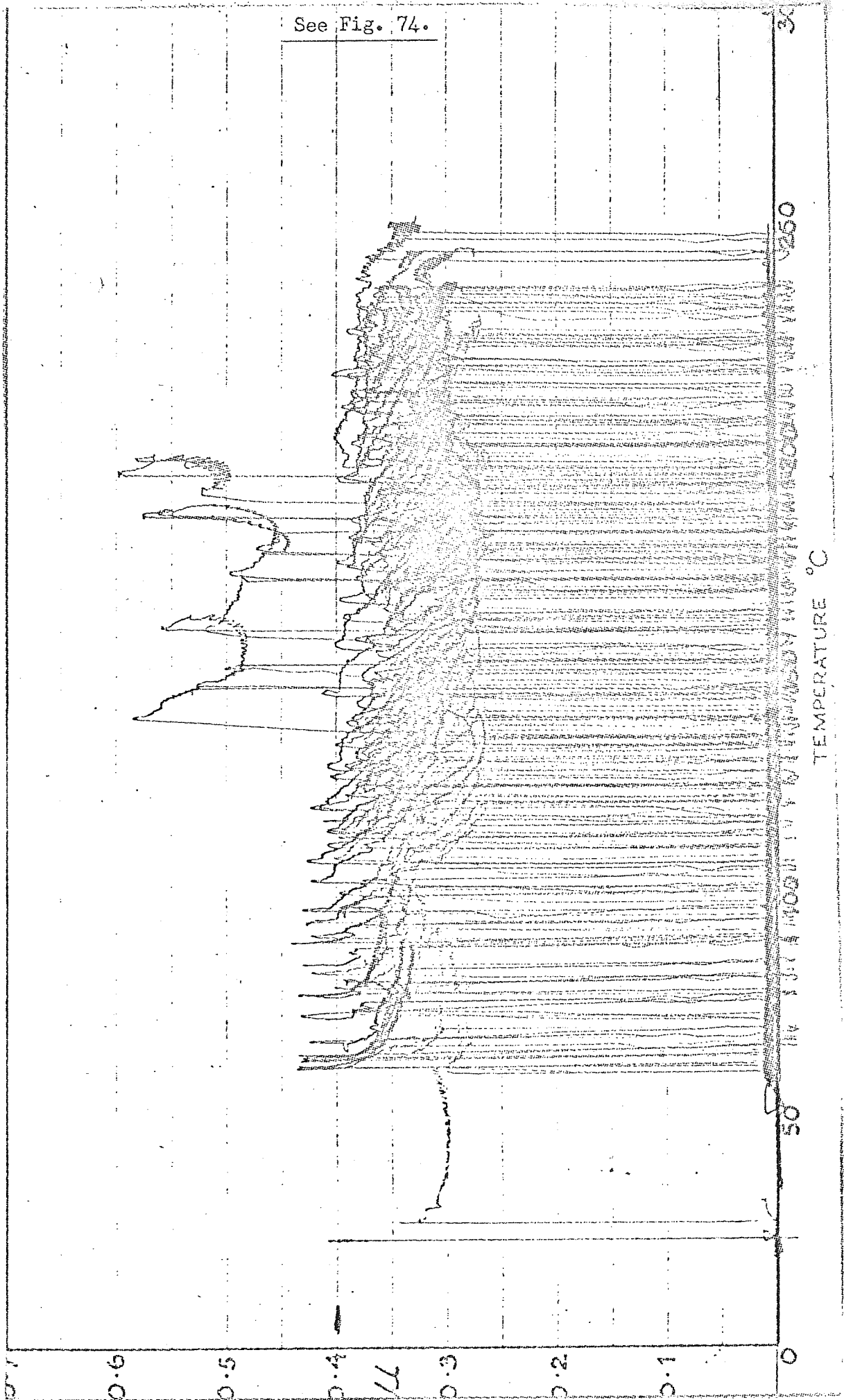

Fig. 76

See Fig. 74.



30

TEMPERATURE °C

50

Fig. 77

See Fig. 74.

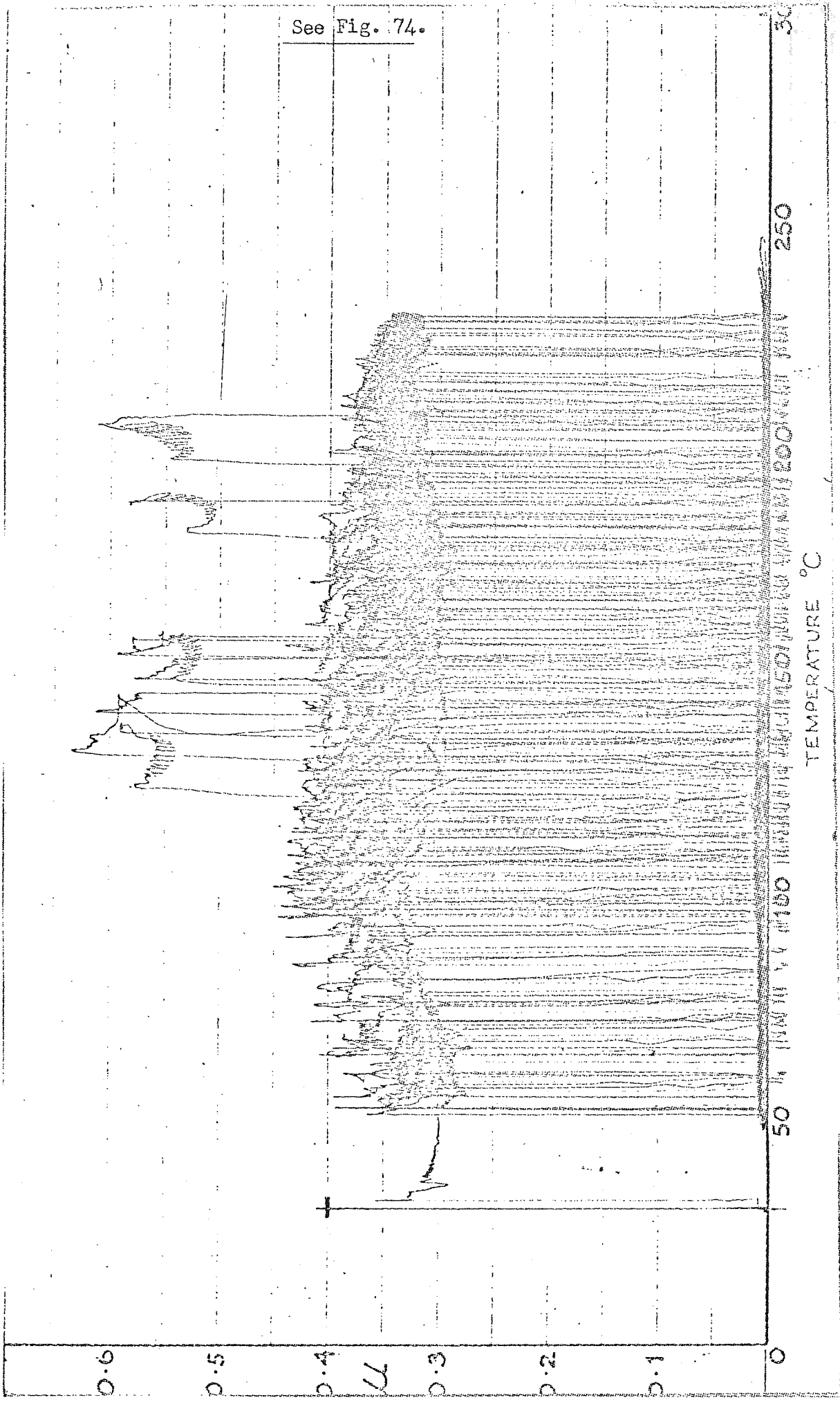

Fig. 78

See Fig. 74.

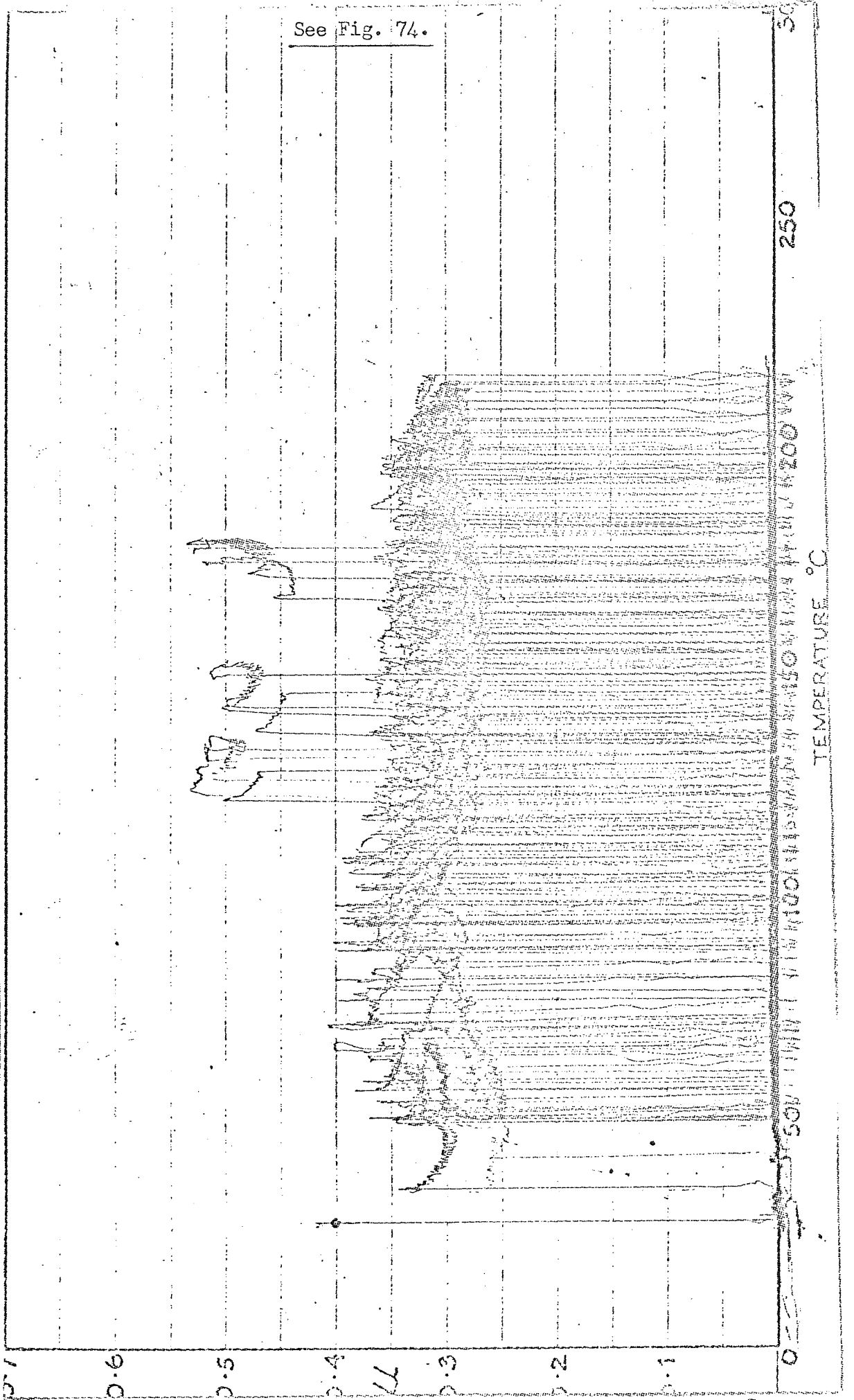

Fig. 79

See Fig. 74.

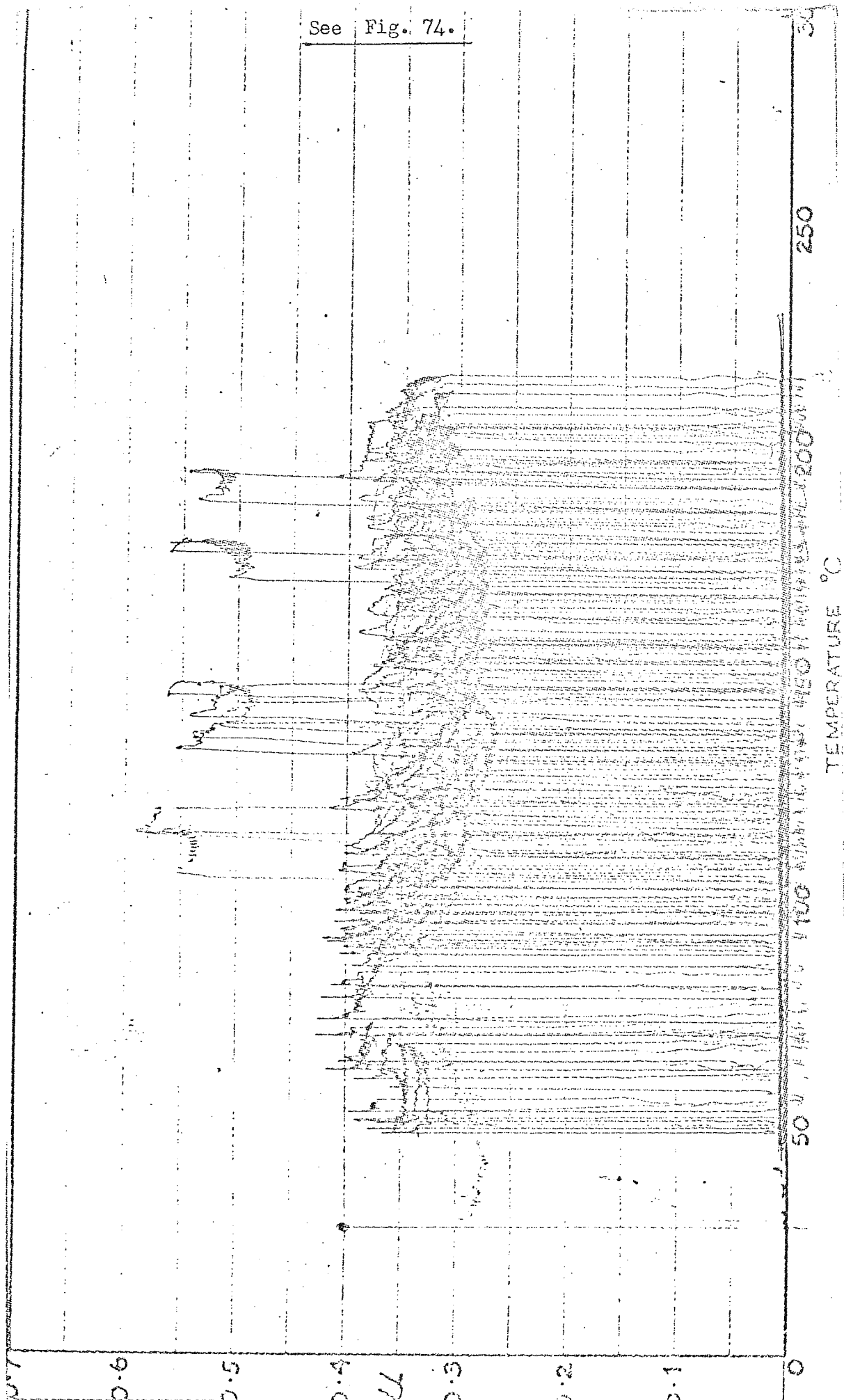

Fig. 80