



If you have discovered material in AURA which is unlawful e.g. breaches copyright, (either yours or that of a third party) or any other law, including but not limited to those relating to patent, trademark, confidentiality, data protection, obscenity, defamation, libel, then please read our [Takedown Policy](#) and [contact the service](#) immediately

THE CHEMICAL STRUCTURE AND MECHANICAL PROPERTIES
OF PHENOLIC RESINS AND RELATED POLYMERS.

by

Peter Richard Spragg, B.Tech., Grad. R.I.C.

A thesis submitted for the Degree of
Doctor of Philosophy
of the University of Aston in Birmingham.

678.632

SPR

-60202 156814

THESIS

September, 1972.

SUMMARY.

Paper-based phenolic laminates are used extensively in the electrical industry. Many small components are fabricated from these materials by the process known as punching. Recently an investigation was carried out to study the effect of processing variables on the punching properties. It was concluded that further work would be justified and that this should include a critical examination of the resin properties in a more controlled and systematic manner.

In this investigation an attempt has been made to assess certain features of the resin structure in terms of thermomechanical properties. The number of crosslinks in the system was controlled using resins based on phenol and para-cresol formulations. Intra-molecular hydrogen bonding effects were examined using substituted resins and a synthetically derived phenol based on 1,3-di-(o-hydroxyphenyl) propane. A resin system was developed using the Friedel Crafts reaction to examine inter-molecular hydrogen bonding at the resin-paper interface.

The punching properties of certain selected resins were assessed on a qualitative basis. In addition flexural and dynamic mechanical properties were determined in a general study of the structure-property relationships of these materials.

It has been shown that certain features of the resin structure significantly influenced mechanical properties. Further, it was noted that there is a close relationship between punching properties, mechanical damping and flexural strain.

This work includes a critical examination of the curing mechanism and views are postulated in an attempt to extend knowledge in this area of the work.

Finally, it is argued that future work should be based on a synthetic approach and that dynamic mechanical testing would provide a powerful tool in developing a deeper understanding of the resin fine structure.

--O-O-O-O-O-O-O--

CONTENTS.

| | Page. |
|---|-------|
| <u>SUMMARY.</u> | i. |
| <u>CONTENTS.</u> | iii. |
| <u>LIST OF FIGURES.</u> | vii. |
| <u>LIST OF TABLES.</u> | xi. |
| <u>CHAPTER 1. INTRODUCTION.</u> | 1. |
| 1. 1. Statement of the problem. | 1. |
| <u>CHAPTER 2. SCOPE AND OBJECTIVES.</u> | 3. |
| 2. 1. Approach to the problem. | 3. |
| 2. 2. Initial ideas. | 3. |
| 2. 3. Programme of work selected. | 3. |
| <u>CHAPTER 3. LITERATURE SURVEY.</u> | 5. |
| 3. 1. Mechanical testing. | 5. |
| 3. 1. 1. Introduction. | 5. |
| 3. 1. 2. High speed shear test (punching). | 5. |
| 3. 1. 3. Description of the punching process. | 6. |
| 3. 1. 4. Description of punching equipment. | 7. |
| 3. 1. 5. Test procedure. | 9. |
| 3. 1. 6. Standard tests. | 9. |
| 3. 1. 7. Flexural testing. | 12. |
| 3. 1. 8. Theory of flexural testing. | 13. |
| 3. 1. 9. Interlaminar shear testing. | 17. |
| 3. 1.10. Beam shear testing. | 17. |
| 3. 1.11. Material considerations. | 20. |
| 3. 1.12. Dynamic mechanical testing. | 22. |

| CONTENTS continued. | Page. |
|---|-------|
| 3. 1.13. Theory of dynamic mechanical testing. | 24. |
| 3. 1.14. Relation of dynamic mechanical properties to polymer structure. | 29. |
| 3. 1.15. Method of testing around frequencies of LH2. | 32. |
| 3. 2. Resin structure. | 32. |
| 3. 2. 1. Historical. | 32. |
| 3. 2. 2. Phenolic resin chemistry. | 33. |
| 3. 2. 3. Physical structure of resins. | 37. |
| 3. 2. 4. Chemical structure of resins. | 38. |
| 3. 2. 5. Plasticisation. | 41. |
| 3. 2. 6. Synthetic work. | 43. |
| 3. 2. 7. Friedel Crafts polymers. | 46. |
| 3. 2. 8. Effect of paper-base. | 49. |
| CHAPTER 4. MECHANICAL TESTING. | 52. |
| 4. 1. Introduction. | 52. |
| 4. 2. Punching properties. | 52. |
| 4. 2. 1. Testing procedure. | 53. |
| 4. 3. Flexural properties. | 53. |
| 4. 3. 1. Introduction. | 53. |
| 4. 3. 2. Development of testing procedure. | 53. |
| 4. 3. 3. Test procedure. | 55. |
| 4. 4. Interlaminar shear properties. | 56. |
| 4. 4. 1. Introduction. | 56. |
| 4. 4. 2. Development of testing procedure. | 57. |
| 4. 4. 3. Test procedure. | 59. |

| CONTENTS continued. | Page. |
|---|-------|
| 4. 5. Dynamic mechanical properties. | 59. |
| 4. 5. 1. Introduction. | 59. |
| 4. 5. 2. Development of testing procedure. | 60. |
| 4. 5. 3. Test procedure. | 61. |
| <u>CHAPTER 5.</u> EFFECT OF CROSSLINK DENSITY. | 65. |
| 5. 1. Introduction. | 65. |
| 5. 1. 1. Experimental. | 66. |
| 5. 1. 2. Discussion. | 68. |
| 5. 2. Phenol-p-cresol system. | 70. |
| 5. 3. Preparation of phenol-p-cresol laminates. | 71. |
| 5. 3. 1. Experimental. | 71. |
| 5. 3. 2. Drying time experiments. | 75. |
| 5. 4. Mechanical properties of phenol-p-cresol laminates. | 76. |
| 5. 4. 1. Discussion of results. | 77. |
| 5. 4. 2. Flexural properties. | 77. |
| 5. 4. 3. Dynamic mechanical properties. | 81. |
| 5. 4. 4. Interlaminar shear properties. | 84. |
| 5. 4. 5. Punching properties. | 85. |
| <u>CHAPTER 6.</u> RESINS BASED SUBSTITUTED PARAFFINS. | 89. |
| 6. 1. Introduction. | 89. |
| 6. 1. 1. Experimental. | 93. |
| 6. 2. Properties of "Propane"-phenol laminates. | 94. |
| 6. 2. 1. Discussion of results. | 94. |
| <u>CHAPTER 7.</u> SUBSTITUTED PHENOLS. | 97. |
| 7. 1. Introduction. | 97. |

| CONTENTS continued. | Page. |
|---|-------|
| 7. 2. Experimental. | 98. |
| 7. 2. 1. o-tertiary butyl phenol resin. | 98. |
| 7. 2. 2. o-methyl phenol resin. | 99. |
| 7. 2. 3. m-methyl phenol resin. | 99. |
| 7. 2. 4. m/p-isopropyl phenol resin. | 99. |
| 7. 3. Properties of substituted phenolic resins. | 100. |
| 7. 4. Discussion of results. | 101. |
| 7. 4. 1. Flexural properties. | 101. |
| 7. 4. 2. Dynamic mechanical properties. | 107. |
| 7. 4. 3. Short beam shear testing. | 108. |
| 7. 4. 4. Punching properties. | 109. |
| <u>CHAPTER 8. PAPER-RESIN INTERACTIONS.</u> | 111. |
| 8. 1. Discussion. | 111. |
| 8. 2. Approach to the problem. | 112. |
| 8. 2. 1. Experimental. | 113. |
| 8. 3. Friedel Crafts resins. | 114. |
| 8. 3. 1. Experimental. | 115. |
| 8. 3. 2. Discussion of the preliminary programme. | 117. |
| 8. 4. Synthesis of Xylok type polymers. | 119. |
| 8. 4. 1. Experimental. | 119. |
| 8. 5. Manufacture of Xylok type laminates. | 120. |
| 8. 5. 1. Experimental. | 120. |
| 8. 6. Properties of Xylok type laminates. | 121. |
| 8. 6. 1. Interlaminar shear properties. | 121. |
| <u>CHAPTER 9. DISCUSSION.</u> | 123. |
| 9. 1. Examination of procedure adopted. | 123. |

| CONTENTS continued. | Page. |
|--|-------|
| 9. 2. Analysis of mechanical properties. | 126. |
| 9. 3. Visual examination of the punched surface. | 130. |
| 9. 4. Paper-resin interactions. | 132. |
| 9. 5. Resin based on 1,3-substituted propane. | 133. |
| 9. 6. Substituted resin. | 134. |
| 9. 7. Fine structure of resin. | 134. |
| 9. 8. Speculations regarding future work. | 139. |
| <u>CHAPTER 10.</u> CONCLUSIONS. | 142. |
| <u>ACKNOWLEDGEMENTS.</u> | 144. |
| <u>APPENDIX 1.</u> CONTROL METHODS. | 145. |
| <u>APPENDIX 2.</u> LAMINATE SPECIFICATION. | 149. |
| <u>APPENDIX 3.</u> TABULATION OF RESULTS. | 152. |
| <u>APPENDIX 4.</u> TORSIONAL PENDULUM CALIBRATION. | 161. |
| <u>APPENDIX 5.</u> ITEMS OF EQUIPMENT. | 164. |
| REFERENCES. | 165. |

LIST OF FIGURES.

| No. | | Page. |
|-----|---|-------|
| 1. | External forces during the punching process. | 7. |
| 2. | Power press. | 8. |
| 3. | Press table layout. | 10. |
| 4. | Cantilever loading. | 15. |
| 5. | Three point loading. | 16. |
| 6. | Four point loading. | 17. |
| 7. | Short beam loading. | 18. |
| 8. | Stress moments in a stressed beam. | 19. |
| 9. | Stress components in three point loading test. | 20. |
| 10. | Anisotropy in laminated board. | 21. |
| 11. | Optimum directions in stressed laminate. | 22. |
| 12. | Plot of stress and strain versus time. | 24. |
| 13. | Vector analysis of stress and strain. | 24. |
| 14. | Components of stress vector. | 25. |
| 15. | Argand diagram of G^I and G^{II} . | 26. |
| 16. | Variation of ϕ with time. | 29. |
| 17. | Plot of $\log \phi$ versus Peak No. | 30. |
| 18. | Shear modulus and logarithmic decrement as a function of time. | 31. |
| 19. | Formation of phenol alcohols. | 34. |
| 20. | Hydrogen bonding in phenol alcohol. | 35. |
| 21. | Structure of cured phenol-formaldehyde resin. | 36. |
| 22. | Chroman ring formation. | 42. |

LIST OF FIGURES continued.

| | Page. |
|---|-------|
| 23. 2,2 ¹ -dihydroxy-5-hydroxymethyl diphenylmethane. | 44. |
| 24. Structural formulae of resins based on substituted paraffins. | 45. |
| 25. 2,3,5,6-tetrafluoro-1,4-dimethoxymethyl benzene. | 49. |
| 26. Formation of Xylok resin. | 50. |
| 27. Flexural testing equipment. | 54. |
| 28. Short beam shear jig. | 63. |
| 29. Interlaminar shear strength as a function of span:depth ratio. | 58. |
| 30. Failure modes in loaded laminate. | 59. |
| 31. Heating box for torsional pendulum equipment. | 64. |
| 32. "Nonius" torsional pendulum. | 62. |
| 33. Phenol/formaldehyde resin still. | 67. |
| 34. Uptake of formaldehyde as a function of time. | 72. |
| 35. Laboratory scale continuous impregnater. | 73. |
| 36. The effect of drying time at 85°C. | 75. |
| 37. Flexural properties of phenol/p-cresol resins. | 78. |
| 38. Generalised picture of flexural behaviour. | 79. |
| 39. Dynamic mechanical properties of phenol/p-cresol resins. | 82. |
| 40. Interlaminar shear strengths of phenol/p-cresol resins at 24°C. | 83. |
| 41. P.Q. as a function of temperature (phenol/p-cresol resins). | 86. |

LIST OF FIGURES continued.

| | Page. |
|---|-------|
| 42. P.Q. as a function of resin composition (phenol/ p-cresol resins). | 87. |
| 43. Element of cured phenol/formaldehyde resin. | 89. |
| 44. 1,3-di(o-hydroxyphenyl)propane. | 90. |
| 45. Reaction mechanism (1,3-di-(o-hydroxyphenyl)propane. | 91. |
| 46. Dynamic mechanical properties of "propane" and phenol resins. | 95. |
| 47. Flexural strength as a function of temperature (Substituted phenols). | 102. |
| 48. Flexural modulus as a function of temperature. (substituted phenols). | 103. |
| 49. Mechanical damping as a function of temperature. (substituted phenols). | 104. |
| 50. Dynamic shear modulus as a function of temperature. (substituted phenols). | 105. |
| 51. Interlaminar shear strength as a function of temperature (m/p isopropyl phenol). | 106. |
| 52. Structure of cellulose. | 111. |
| 53. Reaction of p-X.G.D.M.E. with p-cresyl methyl ether and phenol. | 115. |
| 54. Friedel Crafts resin still. | 116. |
| 55. P.Q. as a function of flexural strain. | 127. |
| 56. P.Q. as a function of dynamic shear modulus. | 128. |
| 57. P.Q. as a function of mechanical damping. | 128. |
| 58. Oxidation of tetra_chloro p-cresol. | 137. |

LIST OF FIGURES continued.

| | Page. |
|---|-------|
| 59. Conversion Chart - p.s.i. to N/m^2 . | 160. |
| 60. Shape factor (μ) as a function of width:depth (C:D) ratio. | 163. |

LIST OF TABLES.

| No. | Page. |
|--|-------|
| 1. Effect of experimental parameters on measured shear stress. | 21. |
| 2. Flexural test conditions. | 56. |
| 3. Conditions of testing with the "Nonius" torsional pendulum. | 62. |
| 4. Summary of preliminary work (p-substituted phenols) | 66. |
| 5. Tensile test results for p-substituted phenols. | 68. |
| 6. Phenol/p-cresol resins used in preliminary investigation. | 70. |
| 7. Phenol/p-cresol resins used in large scale investigation. | 74. |
| 8. Punching properties of phenol/p-cresol resins. | 88. |
| 9. "Propane" based resin. | 90. |
| 10. Flexural properties of "Propane" resin. | 94. |
| 11. Substituted phenols. | 97. |
| 12. Drying time experiment. | 98. |
| 13. Summary of G.L.C. variables. | 100. |
| 14. Interlaminar shear strength of some phenolic resins. | 109. |
| 15. Punching properties of substituted phenols. | 110. |
| 16. Summary of preliminary Friedel Crafts resin programme. | 118. |
| 17. XYLOK resin formulation. | 120. |
| 18. Interlaminar shear strength of XYLOK resins. | 121. |
| 19. Phenol content as a function of punching temperature. | 129. |

CHAPTER 1.INTRODUCTION.1. 1. STATEMENT OF THE PROBLEM.

This problem is concerned with the effect of the chemical and physical structure of laminated plastics on their performance when fabricated by the process known as punching.

These plastic materials contain a paper-based filler incorporated into a matrix of cured phenol-formaldehyde resin. They have good electrical properties at low frequencies and are used extensively as insulating materials. Many small components are fabricated from laminated sheets by cutting and piercing. This is usually achieved with a punch and die in a mechanical press at temperatures between $20^{\circ} - 120^{\circ}\text{C}$.

Experimentally it has long been known that the quality of the parts produced by the punching process depends on the following variables:-

1. Resin composition.
2. Paper-base type.
3. Speed of punching.
4. Punching temperature.

Recently Watson⁽¹⁾ developed a technique utilising an instrumented power press to observe the stress-strain characteristics over a wide range of temperatures during the punching process. He demonstrated that the punching characteristics are a function of paper-base type and processing variables.

This project is complementary to Watson's and its purpose is to investigate the effect of certain features of the resin structure on the punching process. In addition it is hoped to present correlations between the punching data and other thermomechanical properties.

--O--O--O--O--O--O--

CHAPTER 2.

SCOPE AND OBJECTIVES.

2. 1. APPROACH TO THE PROBLEM.

Ideally a synthetic approach to this type of problem might be attempted in which, by the use of carefully selected monomers, systems of known chemical structure could be constructed. This would enable certain features of the resin to be studied. These might include the following:-

1. Freedom of rotation about the internuclear methylene bridge.
2. Number of crosslinks in the cured resin.
3. Interaction of resin with paper-base.

2. 2. INITIAL IDEAS.

It will be seen in Chapter 3 that the purely synthetic approach although attractive might be impractical and was given low priority.

Thus it was decided at an early stage of the work to study those systems in which there was a partial knowledge of the chemical structure. Resins could then be selected in such a manner that they incorporated the chemical features necessary to study the above variables.

2. 3. PROGRAMME OF WORK SELECTED.

The following areas of work were selected as a basis on which to study the problems outlined:-

1. Resins incorporating paraffin bridges to increase the inter-aromatic nuclear distance and therefore molecular flexibility.
2. Phenol/p-cresol resins in varying molar ratios to control the number of crosslinks.

3. Paper-resin interaction.
4. Effect of substituents in the aromatic nucleus.
5. Correlation of other thermomechanical properties with punching quality. These might include:-

5. 1. Flexural properties.
5. 2. Dynamic shear modulus and mechanical damping.
5. 3. Interlaminar shear strength.

-O-O-O-O-O-O-O-

CHAPTER 3.

LITERATURE SURVEY.

3. 1. MECHANICAL TESTING.

3. 1. 1. INTRODUCTION.

Many testing methods have been used to assess the mechanical properties of phenolic laminates. Since most of these are outside the scope of this work, only those methods used in this study will be reviewed here.

3. 1. 2. HIGH SPEED SHEAR TEST (PUNCHING).

Learmonth and Watson⁽²⁾ reviewed the punching of paper-base phenolic laminates and concluded that optimum punching conditions had been well established in industry. It was shown that there was some understanding of the physical nature of the process, but felt there was a need for greater knowledge of the effect of the structural features of the resin, fibre and finished laminate upon the punching process. In a later report⁽³⁾ they describe a technique involving a small power press which is instrumented to measure shear stress and strain during the punching process. Details of results and instrumentation are given and evaluation of data is fully described.

The technique was used to investigate the effects of the processing variables involved in preparing laminates from a given paper-resin system. It was concluded that the punching process is controlled by the relative magnitudes of the applied stress required to initiate and propagate cracks in the laminate and that the crack propagation stage largely controls the quality of the punched article. Results suggest that it is possible to predict from the shape of the

stress-strain curve whether the crack propagation stage is likely to result in satisfactory punching or not.

Punching characteristics are surprisingly insensitive to impregnating, drying and pressing variables, provided that resin content and laminate thickness are standardised. However, unless the impregnated paper sheets are "crossplied" fibre orientation of paper-base appears to effect punching quality. From a study of a series of commercial papers it is suggested that bleached Kraft appears to be the most suitable for demonstrating effects due to the resin.

Crosslinking and chain rigidity both effect the contribution of the resin to the punching quality. The presence of unsaturated hydrocarbon chains was shown to be effective in improving punching quality, possibly by reducing the degree of hydrogen bonding present. (This is thought to enhance the brittle behaviour of the resin).

3. 1. 3. DESCRIPTION OF THE PUNCHING PROCESS.

The punching process is essentially one of high speed shearing. Figure 1 illustrates the external forces involved. (taken from Hojo⁽⁴⁾). The tool set consists of a punch and die. The combination of vertical and horizontal forces created by the pressure of the punch and die results in shear stresses in the region of clearance between the punch and die. A combined pressure pad/stripper plate holds the laminate firmly during the punching and withdrawal of the punch. Minimal clearance between punch and die, together with the restraining forces supplied by the pressure pad and knockout pad, tend to give "pure shear" in the clearance region resulting in clean punched components.

During the process the laminate bends to some extent initially

whilst restrained by the stripper plate. This is followed by a relaxation stage as the laminate is pierced and the punch is withdrawn. To avoid delamination on withdrawal it is essential to ensure small clearance between punch and stripper plate.

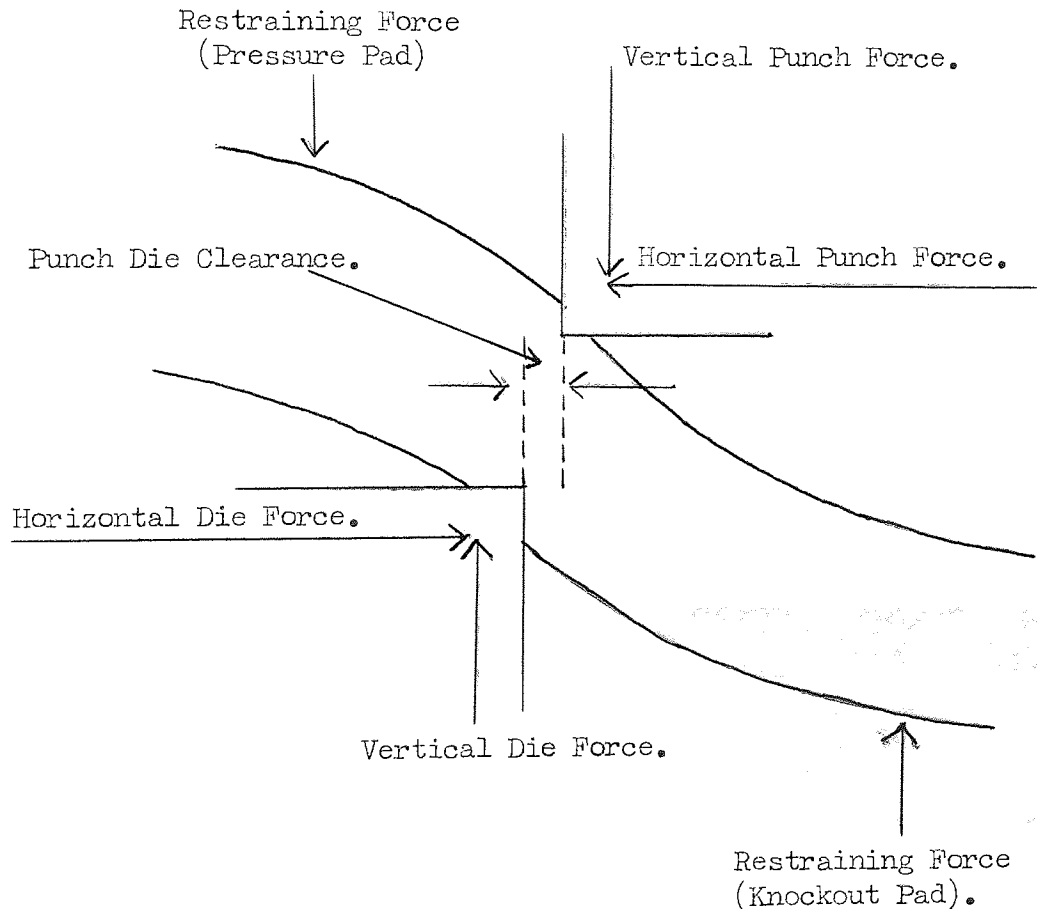

FIGURE 1. EXTERNAL FORCES DURING THE PUNCHING PROCESS.

3. 1. 4. DESCRIPTION OF PUNCHING EQUIPMENT.

A photograph of the press is shown in Figure 2. The punch diameter was 1.502 inches (3.81 cm) and the clearance between punch and die was less than 0.001 inches (0.0023 cm). The combined stripper plate and compression pad was driven by the press ram through rubber buffers. Punching load was measured against time by means of a load transducer comprising of a proof ring which incorporated a

differential-inductance displacement transducer. The load transducer was used in conjunction with a transducer meter, the output of which was fed into one channel of a double beam oscilloscope.

Punch penetration was measured against time by means of a displacement transducer mounted on a support arm, clamped directly to the punch.

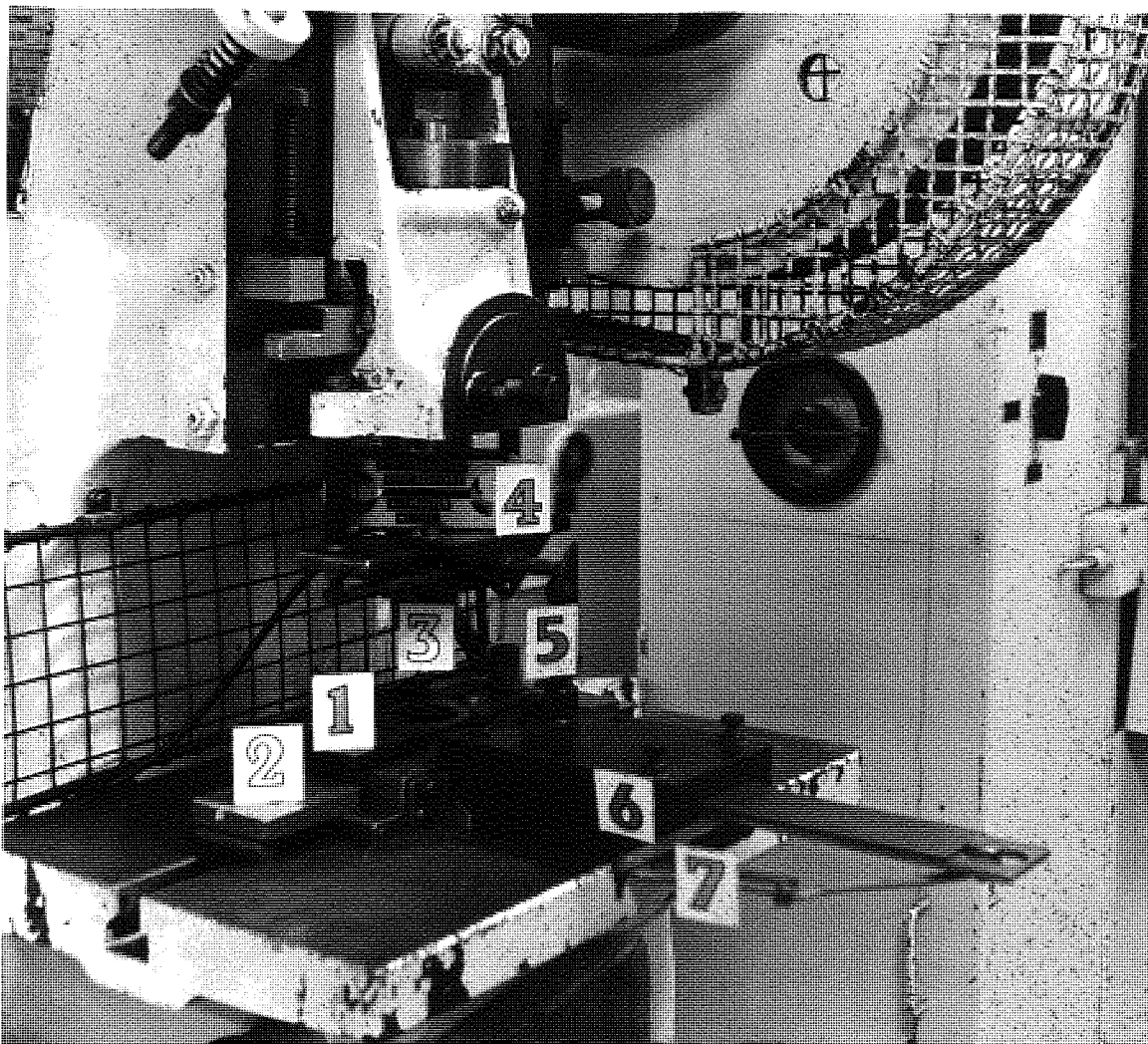

FIGURE 2. POWER PRESS. (Legend - See page 10.).

In operation the oscilloscope was triggered by the signal from the displacement transducer meter and an oscilloscope camera was used to obtain a photograph of the trace.

A heating block (See Figure 3) was used which could be maintained at the correct temperature in a hot air oven until shortly before the test. A rectangular slot through the block contained the test piece. The block served to maintain the laminate at the test temperature from the time it was removed from the oven until the punching operation. A trigger and spring mechanism activated by the press ram ensured that the test piece was projected into the tool set within 0.2 seconds of the punching operation.

3. 1. 5. TEST PROCEDURE.

Five test pieces were punched under each set of experimental conditions. Average plots of stress against time and strain against time were obtained. These were then combined to give stress-strain curves. Stress was defined as load per unit area of sheared surface (i.e. peripheral length of punched contour x sheet thickness). Strain was defined as the percentage ratio of penetration to sheet thickness.

Visual examination of the pierced hole gave an assessment of the punching quality (P.Q. value). Points of 0 - 6 were awarded to each test piece by reference to a set of standards. P.Q. was obtained from the total number of points awarded to the five test pieces. P.Q. values of 10, 15, 20 and 25 were regarded as bad, poor, good and excellent respectively.

It was suggested that the technique might be used as a basis for a pass-fail test and a means of evaluating the effects of molecular structure on the punching quality.

3. 1. 6. STANDARD TESTS.

In addition to the technique described above, other punching tests do exist and have been used to some success in the past.

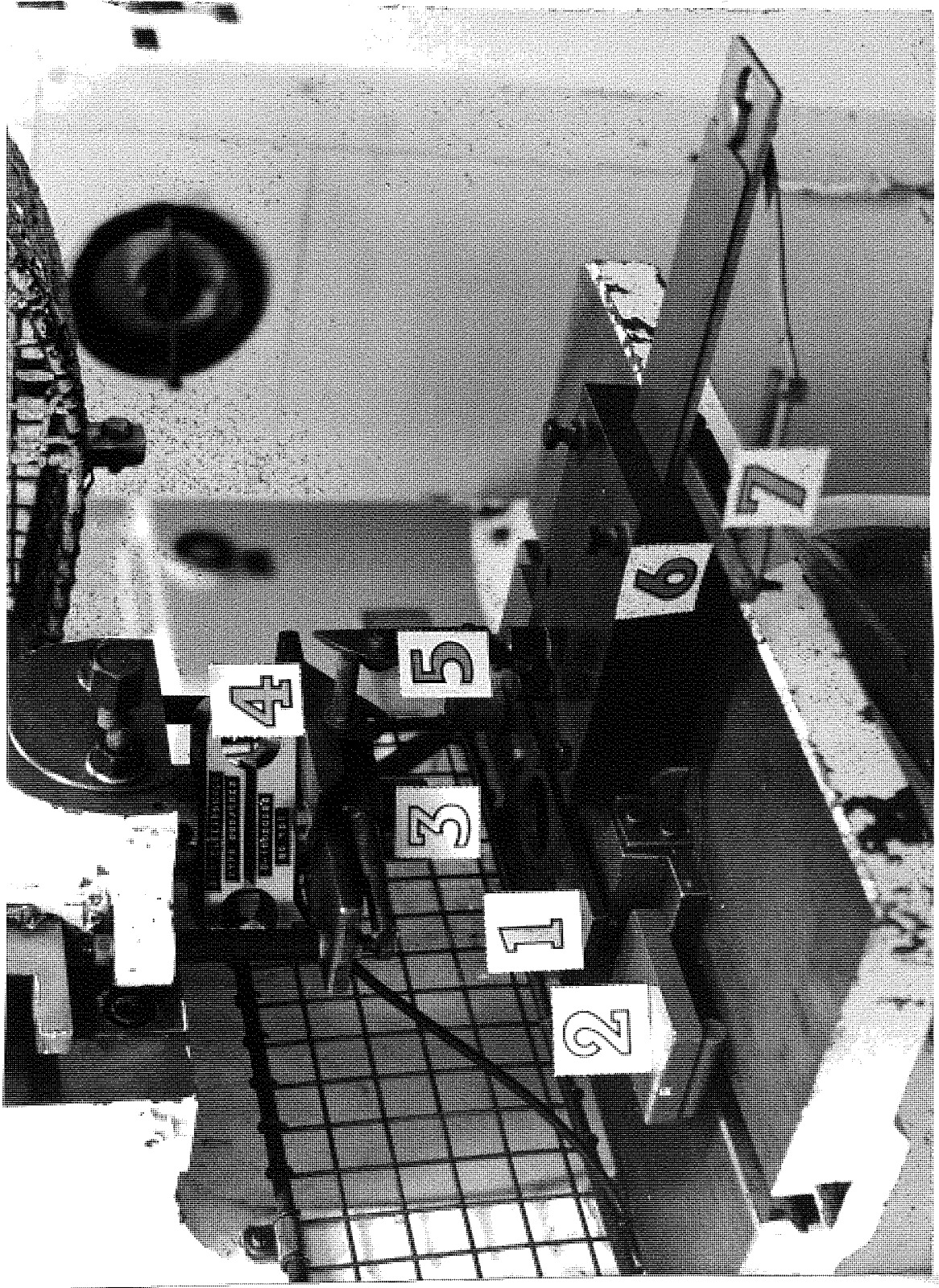

FIGURE 3. PRESS TABLE LAYOUT.

- | | |
|------------------------------------|------------------------------------|
| 1. Stripper plate/compression pad. | 5. Heating block trigger. |
| 2. Die block. | 6. Heating block. |
| 3. Punch. | 7. Heating block spring mechanism. |
| 4. Load transducer. | |

The German standard DIN53 488⁽⁵⁾ employs a carefully specified die set which produces a test piece having nine diamond-shaped holes with apices spaced progressively closer together. The shortest distance remaining uncracked divided by the nominal thickness of the material forms the basis of the evaluation.

The American method A.S.T.M. standard D617-44⁽⁶⁾ is similar and punching ratings are assessed by reference to a prescribed set of standards.

The British standard 2076:1954⁽⁷⁾ is based on a visual examination of a standard punched pattern. In addition British standard 1137:1966⁽⁸⁾ includes an optional punching test. This involves the piercing of a 1/4 inch diameter hole in paper-based phenolic laminates not exceeding 1/8 inches in thickness. Assessment is again visual and qualitative.

Several attempts^(9, 10, 11) have also been made to examine the punching characteristics of paper-based phenolic laminates by rather more quantitative and objective techniques than those described in the national standard methods. These included attempts to examine the connection between the hardness of the laminated plastic and the quality of components punched from them. However, the correlations they produced were not convincing.

It appears then that the Learmonth-Watson technique represents the first genuine attempt to present punching data on a quantitative basis. Further comments regarding this technique will be presented in later chapters.

3. 1. 7. FLEXURAL TESTING.

The ease of deformation of polymeric materials may be defined in terms of flexural strength and modulus. Vincent⁽¹²⁾ prefers this type of loading to tensile testing in the general study of brittleness for the following reasons:-

- 1) The ease of specimen alignment in flexural testing.
- 2) At small strain in flexural loading the actual deformation are sufficiently large to be measured accurately with ease.
- 3) The behaviour of ductile materials at high strains is not recorded as such materials are not broken in a flexural test. This removes the temptation to find significance in irrelevant differences between materials.

Many variations of the flexural test exist but there appears to be little correlation between them. Three distinct types of loading are commonly used:-

- (1) Cantilever loading.
- (2) 3 point loading (simple bending).
- (3) 4 point loading (pure bending).

The first type is a comparative stiffness test and does not claim to give meaningful modulus values, due mainly to difficulties in holding the specimen. In the 4 point loading test shear components are reduced and a considerable length of the beam is subjected to a uniform stress system. The automatic recording of the central deflection is so much simpler for 3 point loading that it is preferred for routine testing. A fuller treatment describing the differences between these three types of flexural testing is presented in Section 3.1.8.

A.S.T.M. standard D790-66 describes a convenient method for the 3

point loading test. A bar of rectangular cross section is tested in flexure as a simple beam. The bar rests on two supports, the distance apart being a function of the specimen dimensions. A load is applied at a constant rate by means of a loading nose midway between the supports. The specimen is deflected until rupture occurs or until the maximum fibre strain of 5% is reached, whichever occurs first.

Flexural properties are dependent upon the following parameters:-

- (1) Temperature.
- (2) Straining rate.
- (3) Span:depth ratio.

Thus when flexural properties are quoted, these parameters must be carefully specified in order that the results are meaningful.

3. 1. 8. THEORY OF FLEXURAL TESTING.

The Bernoulli - Euler treatment⁽¹³⁾ is used to describe the small deflection bending of thin elastic beams.

This treatment assumes that:-

- 1) The normal cross sections of the elastic beam remain in the same plane when the beam is bent.
- 2) All dimensions of the cross section are very small compared with the beam length.
- 3) The beam contains one neutral surface passing through all points of zero strain.

Further, the treatment makes use of the following terms:-

- 1) The intersection of the neutral surface with any cross section is known as the neutral line.

2) The central longitudinal line of the neutral surface is known as the neutral axis.

3) The bending moment is then defined as follows:-

$$M = EI/R. \quad (1)$$

Where:-

M = Bending moment at a cross section.

R = Radius of longitudinal curvature of the beam.

I = Second moment of area of cross section about the neutral line (which equals the moment of inertia of the cross section).

E = Young's modulus.

E x I = Flexural rigidity.

Flexural testing formulae may now be derived if the following conditions hold:-

1) The deflections are small compared with the length. Thus the slope of the beam will be small.

2) The beam is thin, narrow and (usually) of negligible weight.

The three modes of flexural testing may now be treated.

1. Cantilever loading.

The specimen (described in Figure 4) is clamped at one end and subjected to simple bending with the load W. The terms Y and X define the vertical and horizontal axis respectively.

From the Bernoulli - Euler theory for a bent beam the shear force (s) at a distance X along the beam is given in terms of the displacement Y (X):-

$$S = -EI d^3 Y / dx^3 \quad (2)$$

For a cantilever of rectangular section:-

$$\sigma = \frac{6WI}{bd} \quad (3)$$

Where:-

σ = maximum tensile stress in the surface of the bent beam known as the extreme fibre stress. When calculated at the point of failure this is known as the "flexural strength".

b = Width of beam.

d = Depth of beam.

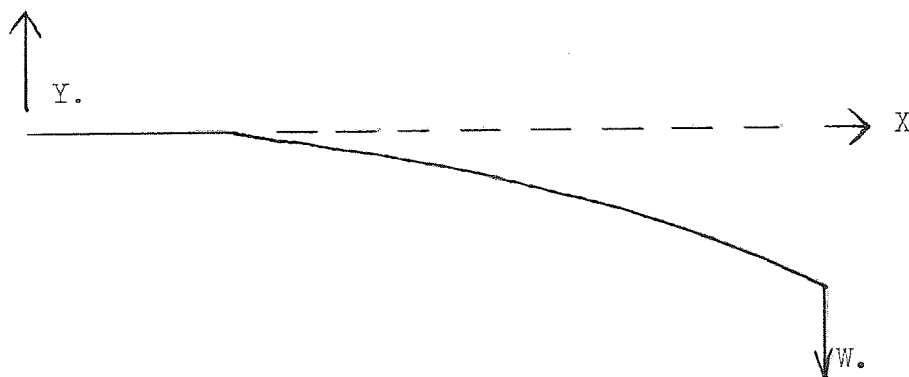

FIGURE 4. CANTILEVER LOADING.

2. Three point loading.

Half of the beam (See Figure 5) is equivalent to a cantilever of length $L/2$ with an applied load $W/2$.

Thus if E is the central deflection of the beam, then:-

$$E = \frac{WL^3}{4bd^3} \quad (4)$$

Where E = Modulus of elasticity.

L = Span between outer supports.

W = Load at deflection.

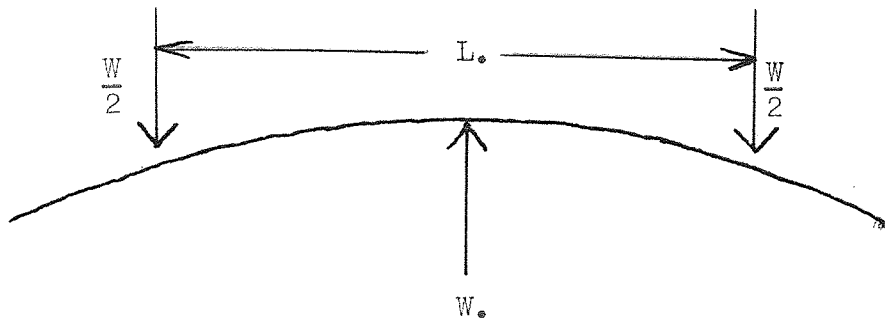

FIGURE 5. THREE POINT LOADING.

To compensate for the effects of beam weight the term (W) in this formula (4) should be increased or decreased by $5/8$ of the beam weight according to whether gravity assists or opposes the central load. However, in the usual method of making the test the zero is measured with the sample deflected by its own weight and no correction is necessary. In any case the deflection caused by the beam weight is commonly negligible. The extreme fibre stress (σ^-) is calculated in the following way:-

$$\sigma^- = \frac{3WL}{2bd^2} \quad (5)$$

3. Four point loading.

The type of loading used here is described in Figure 6.

The extreme fibre stress (σ^-) is described as:-

$$\sigma^- = \frac{3WD}{bd^2} \quad (6)$$

A considerable length of the beam is subjected to a uniform stress system and thus peak stress is not concentrated at the loading points.

Shear components are reduced to a minimum and thus the test approximates to applying a pure couple at each end of the beam.

Further points arising from stress moments in a beam are covered in Section 3. 1. 9.

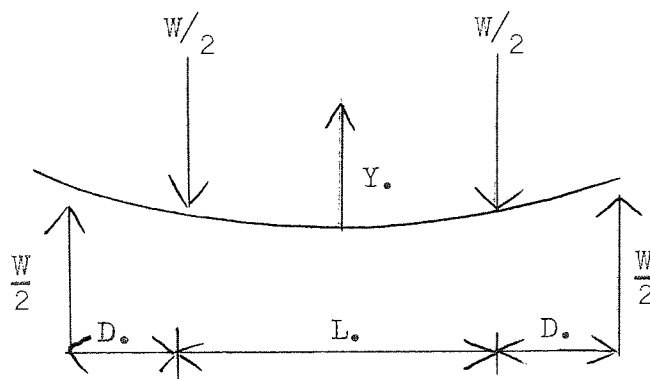

FIGURE 6. FOUR POINT LOADING.

3. 1. 9. INTERLAMINAR SHEAR TESTING.

Interlaminar shear testing presents a simple and rapid method for assessing the resin-paper bond strength in a laminate. It must be recognised that a full theoretical treatment of shear failure modes is a complicated matter and is to some extent beyond the scope of this thesis. However, to understand why this test has been used in this work on a comparative rather than an absolute basis, the following points must be considered.

3. 1. 10. BEAM SHEAR TESTING⁽¹⁴⁾.

This discussion will be limited to the three point loading of short beams. The method is described in Figure 7.

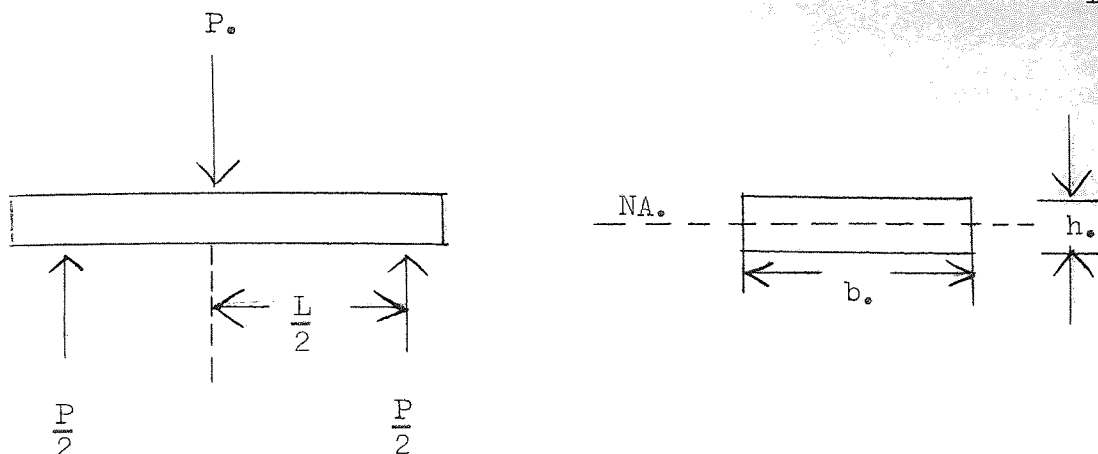

FIGURE 7. SHORT BEAM LOADING.

Description of terms in Figure 7.

P = Load.

L = Span length.

NA = Neutral axis.

h = Depth of beam.

b = Width of beam.

A = $b \times h$ (Area of cross section).

The test is based on the shear and moment distribution of a beam. If the span:depth ratio is small (4-6:1) the shear loads will become proportionally higher than the moment opposed to the normal span used for flexural failure, where shear loads are proportionally smaller than moment. The shear strength (S_s) is described for a rectangular cross section.

$$S_s = \frac{3P}{4A} \quad (7)$$

The flexural strength (σ_s) is given as:-

$$\sigma_s = \frac{3PL}{2bh^2} \quad (8)$$

Combining equations (7) and (8) :-

$$\sigma_s = 2S_s \frac{L}{h} \quad (9)$$

from which:-

$$S_s = \frac{1}{2} \frac{\sigma_s}{L/h} \quad (10)$$

The condition for shear failure is given by:-

$$\begin{matrix} S_s \\ (\text{Max.}) \end{matrix} = \frac{1}{2} \frac{\sigma_s \text{ Max.}}{L/h} \quad (11)$$

This stress is at the neutral axis of the beam and decreases to zero at the outer fibre. Conversely bending stress is zero at the neutral axis and increases to a maximum at the outer fibres. These points are illustrated in Figure 8.

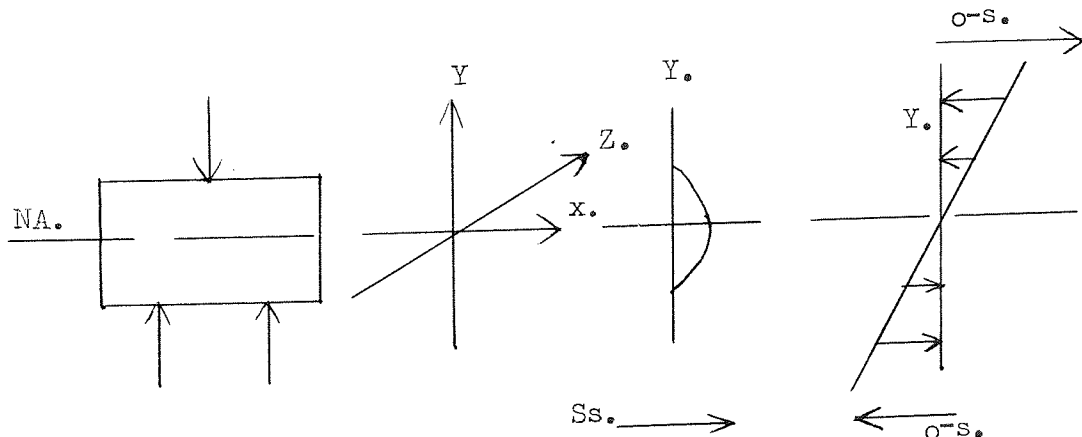

FIGURE 8. STRESS MOMENTS IN A STRESSED BEAM.

Thus the specimen is not in a single type of stressed condition when under load but has tension, compression (which are the components of flexure), and shear existing in some relationship to one and other. Thus Figure 9 illustrates the component zones which exist in the normal three point loading flexural test.

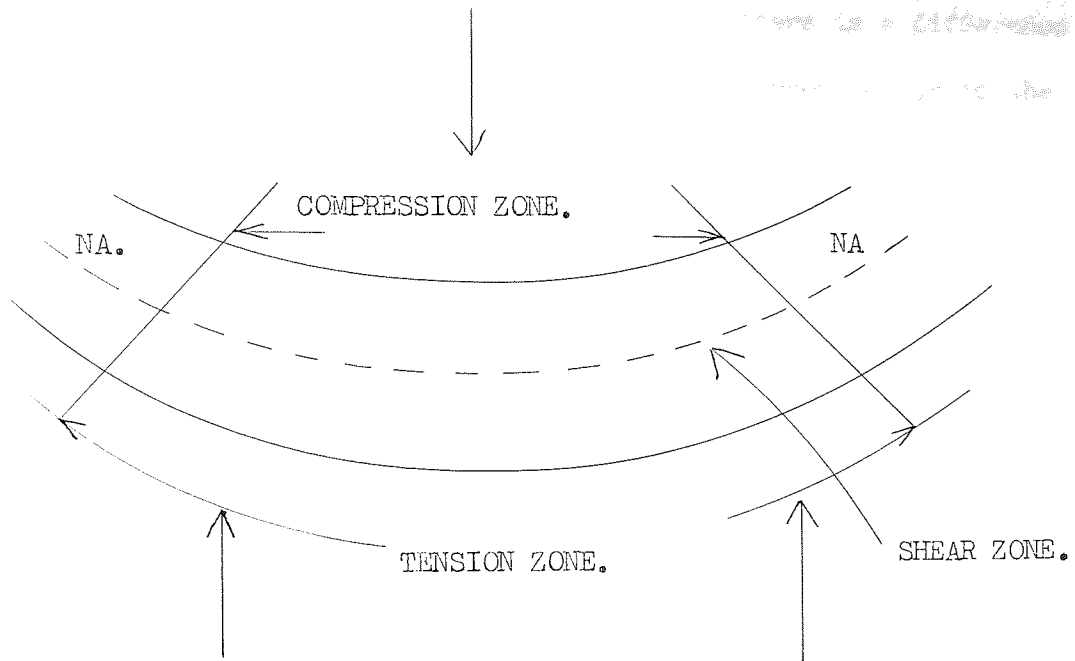

FIGURE 9. STRESS COMPONENTS IN THREE POINT LOADING TEST.

The shear stress measured is dependent upon:-

1. Orientation of filler.
2. Modulus of elasticity and rigidity.
3. Matrix and reinforcement type.

Finally Table 1 summarizes the effect of experimental parameters on the measured shear stress.

Thus it will be appreciated that pure shear conditions are not met in this test. However, if testing conditions are kept constant, the test serves as a guide to compare different laminates in terms of resin-paper bond strength.

3. 1. 11. MATERIAL CONSIDERATIONS.

In the present work laminates were made from unidirectional stacked plies of impregnated bleached Kraft paper. Thus the material

will be mechanically anisotropic. In addition there is a difference in properties between samples cut parallel and perpendicular to the laminations. Figures 10 and 11 illustrate these points.

TABLE 1. EFFECT OF EXPERIMENTAL PARAMETERS ON MEASURED SHEAR STRESS.

| PARAMETER. | SHEAR STRESS MEASURED. |
|------------------|--|
| Specimen width. | No effect. |
| Testing span. | Decreases with increase in span. |
| Rate of loading. | Very little effect in the range 0.05-0.4 in/min. (1.3 x 1.0 mm/min.) |

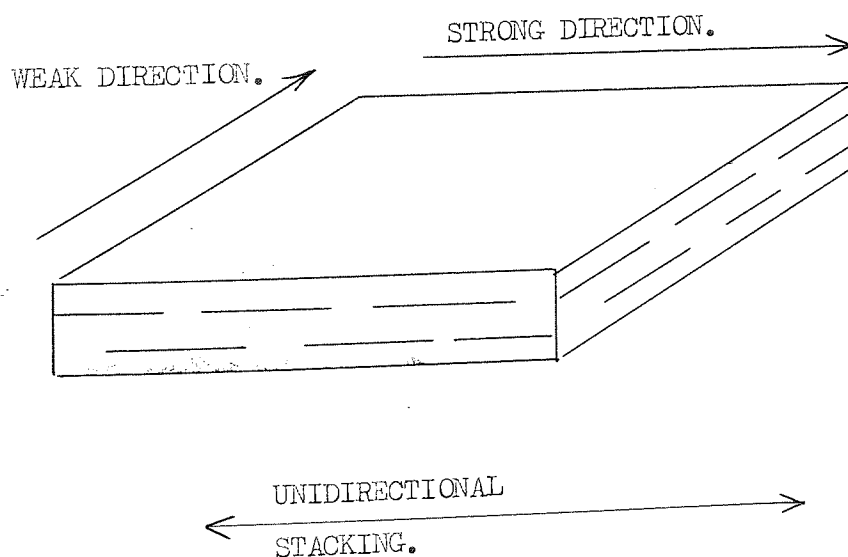

FIGURE 10. ANISOTROPY IN LAMINATED BOARD.

| TYPE OF STRESS. | OPTIMUM DIRECTION. | WORST DIRECTION. |
|-----------------|---|--|
| FLEXURE. |  |  |
| TENSION. |  |  |

FIGURE 11. OPTIMUM DIRECTIONS IN STRESSED LAMINATE.

3. 1. 12. DYNAMIC MECHANICAL TESTING.

Dynamic mechanical tests measure the response of a material to stresses which vary with time⁽¹⁵⁾. The deformation of the test specimen is determined as a function of an applied stress which varies sinusoidally. It is then possible to measure the dynamic modulus (shear or tensile) and the mechanical damping or energy

dissipation. Polymeric materials have some of the properties of both elastic materials and viscous materials. When work is done in deforming such a substance, part of the energy is stored as potential energy and part is dissipated as heat. The energy dissipated as heat manifests itself as mechanical damping.

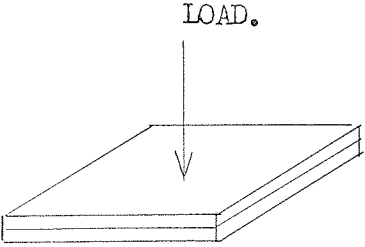
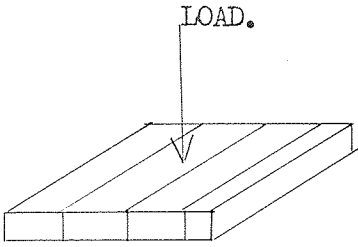
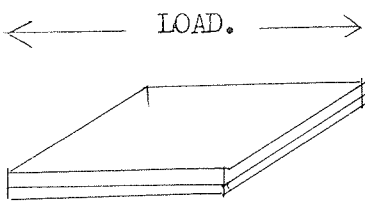
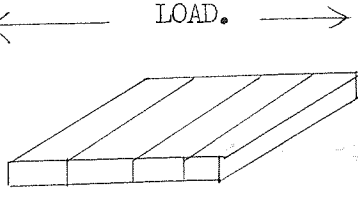
The simplest apparatus in this field of testing is the torsional pendulum (16, 17). In the Nonius equipment one end of the specimen is rigidly clamped while the other end is clamped to a freely supported bar of known moment of inertia. When the inertia member and specimen is twisted and then released the system oscillates and the amplitude of the oscillations will decrease with time due to damping by the specimen. The shear modulus (G) is related to the period of the oscillations while the mechanical damping (or logarithmic decrement) is determined by the rate of decrease of the amplitude of the angle of twist.

The period of the torsional pendulum is very sensitive to minor molecular structural differences in the specimen. The mechanical properties are strongly dependent upon glass transition temperatures, degree of crosslinking, crystallinity and other details of the inter- and intra-molecular structure of the polymer chain. For example as the degree of crosslinking increases the damping peak shifts to a higher temperature and the transition region broadens out. In addition the modulus above the glass transition temperature increases. These effects have been demonstrated for a phenol-formaldehyde moulding material at different degrees of cure⁽¹⁸⁾.

3. 1. 13. THEORY OF DYNAMIC MECHANICAL TESTING⁽¹⁹⁾.

In the torsional pendulum a stress is applied sinusoidally to the sample. The resultant strain is also sinusoidal but since polymers are viscoelastic materials there is a delayed response which causes the deformation to lag behind the applied stress. This lag is a function of the relaxation time of the various molecular segments and hence of the stiffness of the main chain. Thus maximum stress and strain will be out of phase, as illustrated in Figure 12.

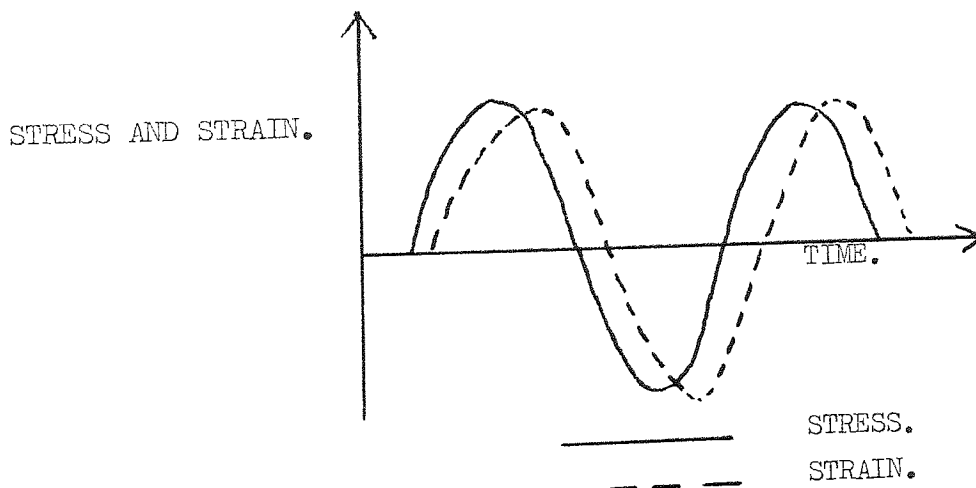
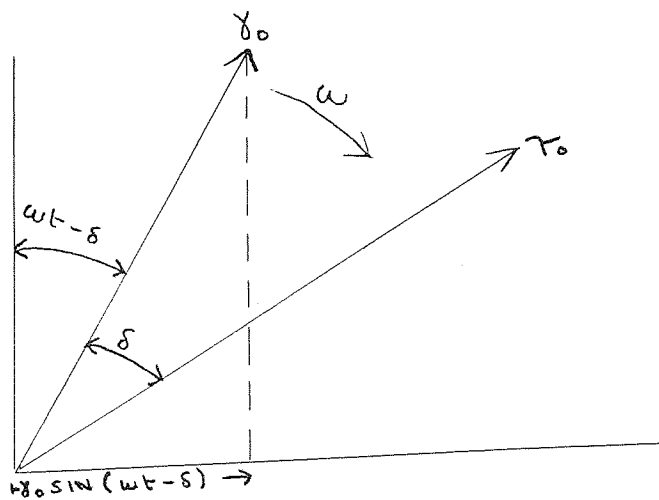

FIGURE 12. PLOT OF STRESS AND STRAIN VERSUS TIME.

The sinusoidally varying stress may be treated as a rotating vector as shown in Figure 13.



Where ω = Angular velocity.

δ = Angle by which the stress vector leads the strain vector.

The stress vector τ_0 may be decomposed into two components. (See Figure 14). One component is directly in phase with the strain and the other component is 90° out of phase with the strain.

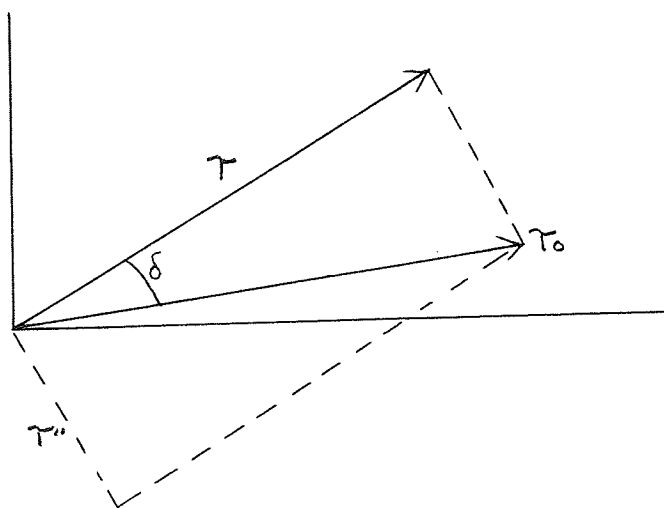

FIGURE 14. COMPONENTS OF STRESS VECTOR.

These two components may now be defined:-

1. In phase $\tau' = \tau_0 \cos \delta$ (12)
2. 90° out of phase $\tau'' = \tau_0 \sin \delta$ (13)

Thus there will be two moduli:-

1. An elastic or real modulus, termed G' .
2. A loss or imaginary modulus termed G'' .

The moduli G' and G'' are the real and imaginary parts of a complex modulus $G^{\mathbb{K}}$.

thus:-

$$G^{\mathbb{K}} = G' + iG'' \quad (14)$$

where:- $i = \sqrt{-1}$

This may be represented on an Argand diagram. (Figure 15).

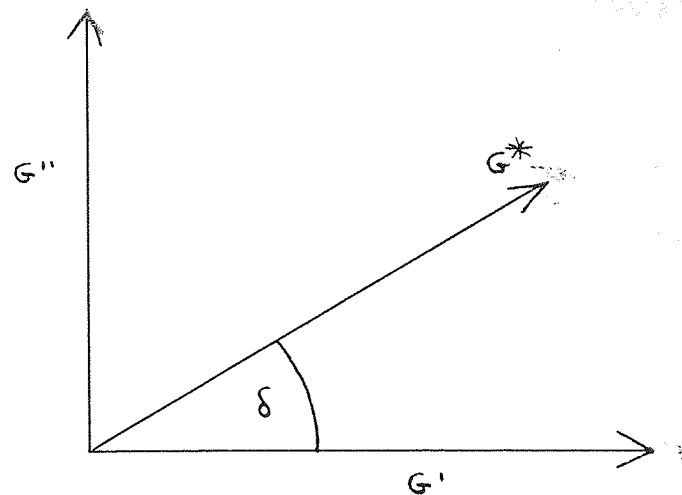

FIGURE 15. ARGAND DIAGRAM OF G' and G'' .

Thus:-

$$G' = G^* \cos \delta \quad (15)$$

$$G'' = G^* \sin \delta \quad (16)$$

$$\text{Loss factor } \tan \delta = \frac{G''}{G'}$$

From equations (15) and (16) :-

$$G'^2 = G^{*2} \cos^2 \delta \quad (17)$$

$$G''^2 = G^{*2} \sin^2 \delta \quad (18)$$

$$\text{Now, since } \sin^2 \delta + \cos^2 \delta = 1.$$

then:-

$$G'^2 + G''^2 = G^{*2} \quad (19)$$

The equation of motion for the torsional pendulum is given

by (20, 21, 22):-

$$\frac{I d^2 \theta}{dt^2} + K G^* \theta = F(t) \quad (20)$$

Where:-

I = Moment of inertia of the oscillating system.

θ = Angle of twist.

G^* = Complex shear modulus.

K = Constant according to the dimensions of the specimen.

The first term gives the inertia forces and the second term gives the force required to twist the specimen. The last term $F(t)$ is the external force which varies with time. For free vibrations there is no external force, thus $F(t) = 0$.

Combining equations (14) and (20) the equation of motion of free vibrations becomes:-

$$I \frac{d^2\theta}{dt^2} + K(G' + i G'') \theta = 0. \quad (21)$$

Where, G' and G'' are assumed to be independent of frequency. Instead of the loss factor a damping term, logarithmic decrement, may be defined:-

$$\Delta = \ln \phi_1 / \phi_2. \quad (22)$$

Where, ϕ_1 , ϕ_2 are the amplitudes of successive oscillations, it may be shown that:-

$$\frac{G''}{G'} = \frac{4 \pi \Delta}{4 \pi^2 + \Delta^2} = \tan \delta \quad (23)$$

from which:-

$$\Delta = \frac{\pi G''}{G'} \quad (24)$$

shear modulus of rigidity may be expressed as the total modulus G^x and again it may be shown that this is expressed as follows:-

$$G = \frac{64 \pi^2 I V^2 L}{10 u C D^3} \quad \text{N/m}^2 \quad (25)$$

Where:-

- I = Moment of inertia of the oscillating system.
- L = Length of specimen between the clamps in cm.
- u = Shape factor depending on the C/D ratio.
- C = Specimen width in cm.

D = Specimen thickness in cm.

V = Frequency of oscillation in Hz.

This equation (25) holds for specimens of rectangular cross section.

$$\text{Also, } V = \frac{nb.}{a.} \quad \text{Hz.} \quad (26)$$

Where:-

a = Distance in cm of 2n+1 intersections of the time axis

(See Figure 16).

b = Velocity of drum in cm/min.

The shape factor \sqrt{u} is obtained from a graph constructed from literature values of \sqrt{u} and $C/D^{(2)}$. The value is used for the moment of inertia and may be one of five depending on the position of the weights on the pendulum cross bar:-

| | | |
|-----|------------------------------------|-------------------------|
| I0. | (No weights). | = $29/\sqrt{u}Nm^2$. |
| I1. | (8.5 cm. from centre of cross bar) | = $177/\sqrt{u}Nm^2$. |
| I2. | (11 " " " " " ") | = $255/\sqrt{u}Nm^2$. |
| I3. | (16.2 " " " " " ") | = $551/\sqrt{u}Nm^2$. |
| I4. | (23 " " " " " ") | = $1074/\sqrt{u}Nm^2$. |

A method of determining the moments of inertia is described in Appendix IV.

The logarithmic decrement (Δ) is given by:-

$$\Delta = n \phi_1/\phi_2 = n \phi_2/\phi_3 \quad \text{etc.}$$

This is determined by a graphical method (See Figures 16 and 17) by plotting peak No. against log (Peak height) on semi logarithmic graph paper. A straight line is obtained and may be determined from the expression:-

$$\Delta = \frac{\log_{10}(\phi_0) - \log_{10}(\phi_p)}{0.4343 (P/2)} \quad (27)$$

Where:-

P = Arbitrary determined Peak No.

ϕ_0 = Height of the initial peak.

ϕ_p = Height of the P^{th} peak.

It will be seen from Figure 16 that this gives a more accurate assessment of Δ since both troughs and peaks are measured. Whereas in equation 22 only peak heights on one side of the datum line are measured.

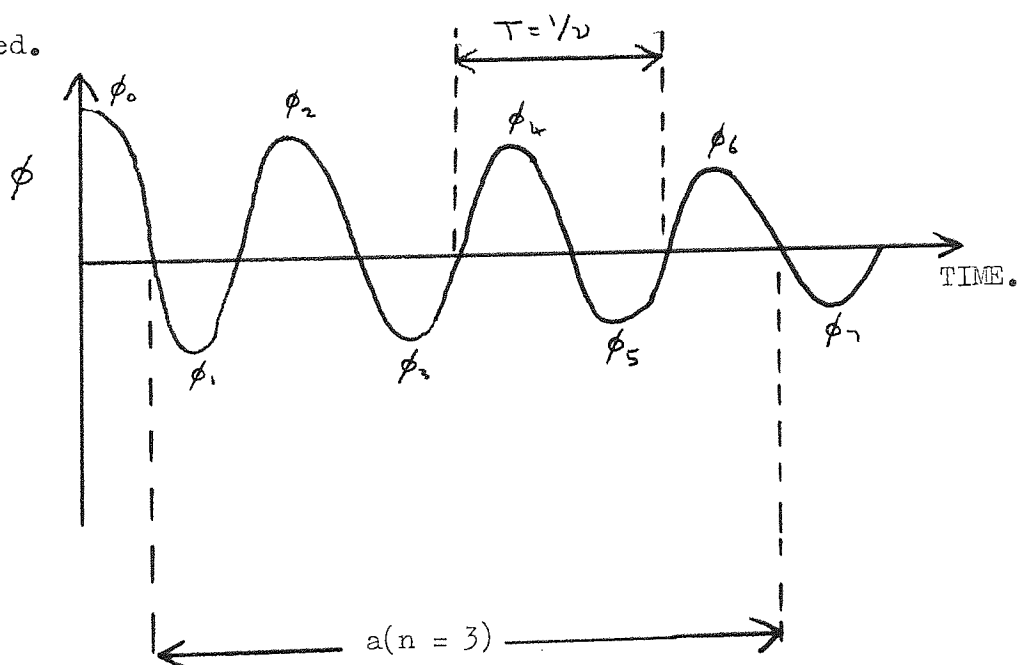

FIGURE 16. VARIATION OF ϕ WITH TIME.

3. 1. 14. RELATION OF DYNAMIC MECHANICAL PROPERTIES TO POLYMER
STRUCTURE.

Although the torsional pendulum is mainly used to study the structure-property relationship of thermoplastic materials, it will

be seen in later chapters that the technique has been utilised to some value in this project. The theory of structure-property relationships has been discussed extensively in the literature^(21,22). However, it is considered pertinent to briefly discuss the treatment used in this section of the thesis.

A typical set of data for an amorphous polymer is shown in Figure 18. Here shear modulus and damping have been determined as a function of temperature.

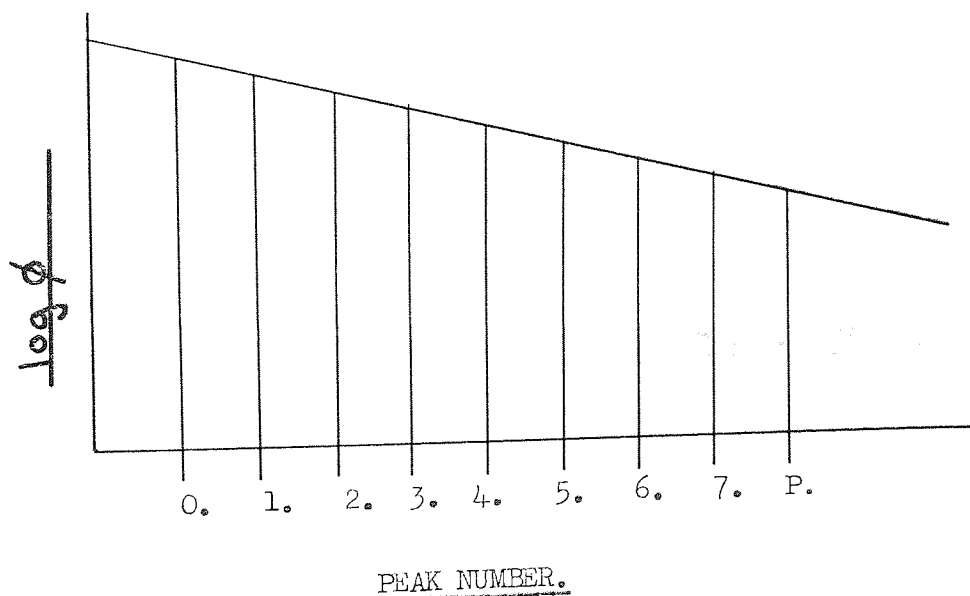

FIGURE 17. PLOT OF LOG δ 'V' PEAK NO.

At low temperatures the material is rigid with a high modulus. On raising the temperature the modulus slowly decreases until the glass transition region is reached where the modulus dramatically decreases. This is due to the onset of chain segment mobility. At low temperatures the chain segments are "frozen in" and cannot readily respond to an applied stress. In the higher temperature "rubbery" region the segments have greater mobility and become free to move when a stress is applied. The logarithmic decrement curve illustrates that damping goes through a large maximum in the glass

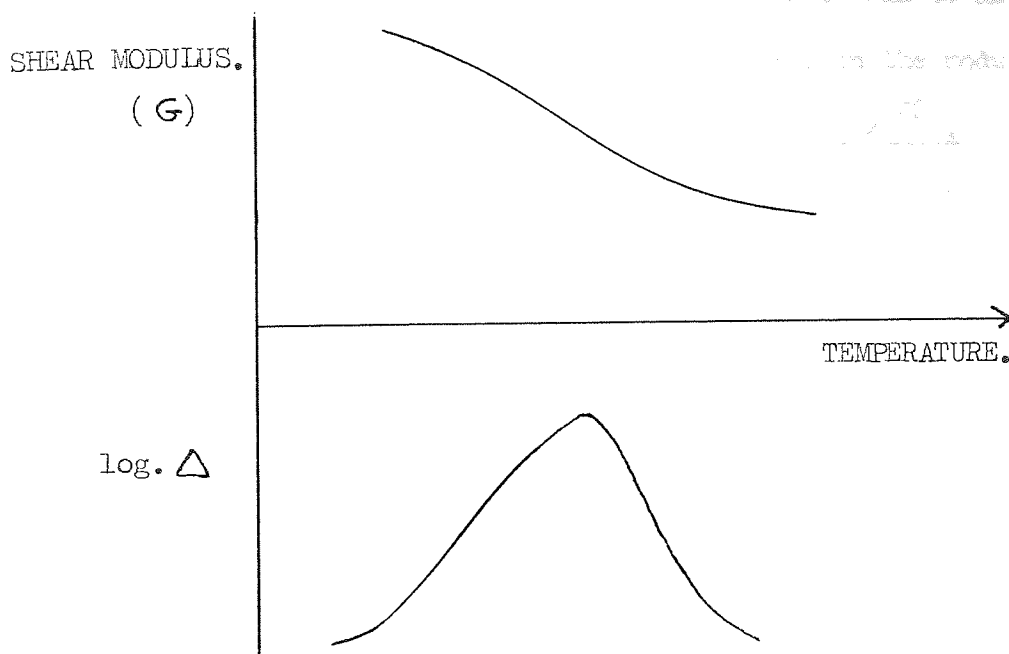

FIGURE 18. SHEAR MODULUS AND LOGARITHMIC DECREMENT AS A FUNCTION OF TEMPERATURE.

transition region. This is readily understood for the following reasons. In the "frozen in" state each molecular segment acts as though it were a very stiff spring. However, in the "rubbery" state a mobile segment behaves as if it were a very weak spring. Thus for a given deformation a given weak spring can store less potential energy than a stiff spring. Therefore, the weak springs (mobile segments) must dissipate most of their energy as heat during the transformation of stiff to weak springs. This heat generation is the source of mechanical damping. The damping is low when all the springs are weak or stiff. When a high proportion of the stiff springs change to weak springs in a time interval comparable to the time of one oscillation, the damping is high. As the temperature increases further above the T_g , the density decreases (hence volume increases)

and the additional freedom of the polymer segments lead to an increase in the mechanical loss and corresponding decrease in the modulus.

3. 1. 15. METHOD OF TESTING AROUND FREQUENCIES OF 1Hz⁽²⁰⁾.

The specimen is clamped in a vertical position to a rigid heavy ground plate, its upper end is attached to the inertia beam (or pendulum) which consists of a clamp, a vertical cylinder and a horizontal cross bar. This inertia beam is suspended from a thin wire attached to one arm of a balance. This balance pivots on a vertical column standing on the ground plate. A weight on the other arm counterbalances the weight of the inertia beam so as to prevent longitudinal stresses on the material and to allow for thermal expansion. After a little twist the specimen is left free and performs free damped oscillations. A mechanically revolving drum covered with waxed paper is positioned about 1 mm from the end of the inertia beam. A high voltage spark from a needle point at the end of the inertia beam causes a darkening of the waxed paper. Thus a trace of the vibrations is recorded in the form given in Figure 16. The weights on the cross bar are positioned so that the frequency of vibration is as near as possible to 1Hz. The frequency can further be controlled by specimen dimensions and the length of the specimen between the vertical clamps. To maintain the specimen and its surroundings at a specified temperature thermostatted gas is blown into the chamber enclosing the specimen. Thermocouples may be used to record the actual temperature of the specimen during the test.

3. 2. RESIN STRUCTURE.

3. 2. 1. HISTORICAL.

The reaction of phenols and aldehydes to give clear resinous products has been known for many years. It took the enterprising

ability of the great Belgium Chemist, L. H. Baekeland, however, to exploit these resins commercially⁽²³⁾. He suggested that the use of fillers such as wood flour might be used to overcome the inherent brittleness of the cured resin. Interest in this field developed rapidly and it soon became apparent that paper and fabrics could be impregnated and subsequently laminated into chemically resistant tough sheets. Laminated and moulded phenolic products represent a high proportion of the large tonnage of plastics manufactured today and there is little evidence to suggest that the demand will fall in the immediate future.

3. 2. 2. PHENOLIC RESIN CHEMISTRY.

The manufacture of laminating varnish involves the preparation of a resole by the base catalysed reaction of phenol (or a derived compound) with formaldehyde. The phenol|formaldehyde molar ratio usually lies within the range 1:1.15 - 1:1.45.

Although opinions vary slightly a present-day explanation of the reaction mechanism is described by Royals⁽²⁴⁾ who pictures it as a Lederer-Manasse reaction. (See scheme in Figure 19). He considers that in the presence of a base phenol is converted to the phenoxide anion. Electrophilic attack of formaldehyde at the ortho and para positions leads to the formation of phenol alcohols. As the condensation proceeds these may then undergo self-condensation, some by the formation of di-hydroxybenzyl ethers. However, as the resin grows in molecular size, condensation occurs within the resin and at a lower pH with the resultant formation of methylene bridges.

SCHEME 1. ATTACK OF OH^\ominus TO GIVE TRANSITION STATES

(a) AND (b)

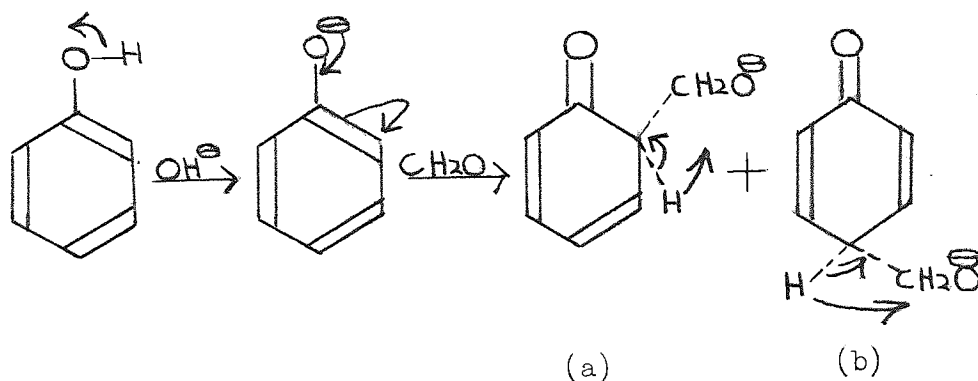

SCHEME 2. INTRAMOLECULAR HYDROGEN TRANSFER TO GIVE THE RESONANCE STRUCTURES (c) AND (d).

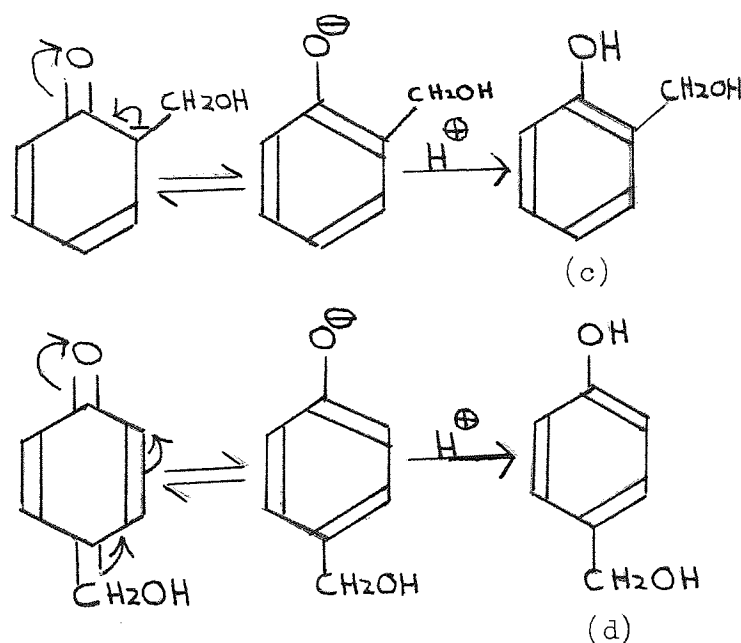

FIGURE 19. FORMATION OF PHENOL ALCOHOLS.

Francis and Yeddanpalli⁽²⁵⁾ studied the alkaline condensation of a series of mono, di and tri hydroxymethyl phenols. They found that the p-hydroxymethyl group is more reactive than the corresponding ortho substituent. Two explanations were presented for this:-

1. The reactivity of the ortho substituent is lowered because of the possibility of intramolecular hydrogen bonding with the phenolic hydroxyl group.

2. There is a small positive charge on the methylene carbon atom due to the electron attracting ability of the phenolic hydroxyl group. The methylene group is thus reactive towards positions of high electron density.

The first explanation is in accordance with Martin⁽²⁶⁾ who presents spectroscopic evidence for the existence of intramolecular hydrogen bonding in o-hydroxymethyl phenol (Figure 20).

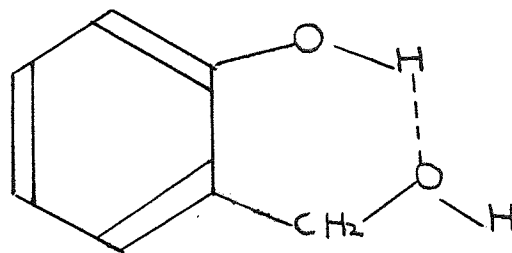

FIGURE 20. HYDROGEN BONDING IN PHENOL ALCOHOL.

Under typical laminating conditions of high temperature and pressure (150°C, 1000 p.s.i. - 6.9 MN/m²) a considerable degree of crosslinking is likely to take place. In this so called "C" stage the polymer is no longer soluble or fusible. It appears that the extent of crosslinking has never been clearly established in the literature.

It is clearly impossible to draw the structure of such a system but the structure depicted by Carswell⁽²⁷⁾ might be considered a typical representation (See Figure 21).

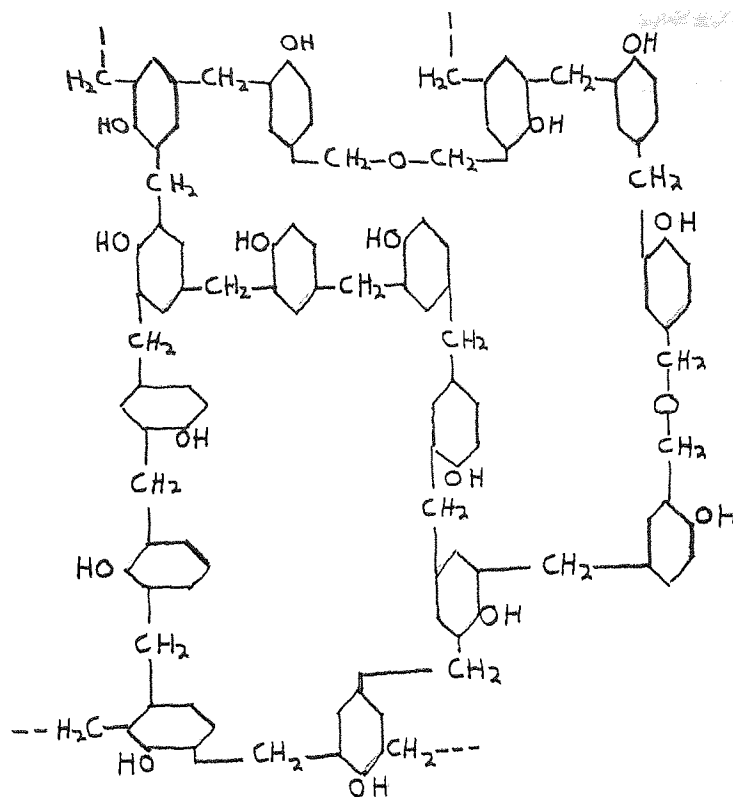

FIGURE 21. STRUCTURE OF CURED PHENOL-FORMALDEHYDE RESIN.

Since the early 1930's workers have strived to gain a deeper insight into the chemistry of phenolic resins. As a result of their persistence it is possible to some degree to predict the course of a particular reaction system. Further, it is sometimes possible to present ideas on the physical and chemical properties of the final polycondensate, if only on an empirical basis.

3. 2. 3. PHYSICAL STRUCTURE OF RESINS.

By considering the functionality of a phenolic aromatic nucleus it should be possible from a knowledge of primary bond strengths to calculate the mechanical strength of the cured resin. However, established tensile strength determinations give a value of $1/550$ of the calculated figure and Young's modulus value are about 10% that of theoretical⁽²⁸⁾. Thus it appears that either:-

1. Three dimensional crosslinking is incomplete,

or

2. Stresses are unevenly distributed in the material and thus concentrations at imperfections are giving failure at low values.

Houwink⁽²⁹⁾ considers that structural defects are present in the cured resin structure. In the neighbourhood of these a concentration of stresses is assumed to occur leading to the observed low technical strength. He suggests that these flaws are due to the formation of less than the theoretical number of methylene bridges. Thus as the molecule grows in size addition to a single active site becomes increasingly less probable from steric considerations.

The final cured phenoplast then, has a colloidal gel type structure in which the dispersed particles are highly crosslinked nuclei while the continuous phase is a matrix of less highly polymerised material. These considerations are confirmed to some extent by X-ray and microscopic work⁽³⁰⁾. However, since these techniques are rather unsuitable for amorphous resinous system, such data must be treated with some caution.

3. 2. 4. CHEMICAL STRUCTURE OF RESINS.

Since the phenoplast has a largely colloidal gel type structure, it is difficult to confirm the above physical theories by the usual instrumental technique.

Classical chemical techniques have been used to separate and identify molecular species from cured resin compositions. By comparing these with synthetically derived compounds, it is possible to obtain a considerable amount of information about the chemical structure.

Chromatography and spectroscopy has come to the aid of resin chemists to provide a rapid means of resin analysis.

Freeman⁽³¹⁾ has developed a paper chromatographic technique for studying resins in a low degree of condensation. He used a mixture of 1-butanol and concentrated ammonium hydroxide (4:1 by volume) as a solvent and p-nitrobenzene diazonium fluoroborate as indicator. Eighteen compounds were identified, mainly phenol alcohols and dihydroxydiphenyl methanes and these were characterised by their R_f values. Higher molecular weight materials were not reported in this work.

Zulaica⁽³²⁾ et al have studied the pyrolysis products of some simple resins by gas liquid chromatography. It was predicted that a poly-condensate based on pure phenol should yield phenol itself, 2 and 4 methyl phenols, 2, 4 and 2,6 dimethyl phenols and 2, 4, 6 trimethyl phenols in varying proportions. Experimental work confirmed these views.

The curing of resoles in the range 70 - 200° has been studied by infra-red spectroscopy^(33, 34). It was noted that heating causes

changes in the hydrogen bond association of the phenolic hydroxyl group. At 70°C ether linkages were formed. At higher temperatures carboxylic acids and quinone methides appeared and conjugation in the aromatic ring became distorted. Ether linkages disappeared completely at 200°C, hydrogen bond bands weakened and the general absorption in the 3200 - 600 cm^{-1} region became distinctly more peaked.

Bender⁽³⁵⁾ discusses the effect of hydrogen bonding on the properties of phenolic resins intermediates. He suggests that this has a considerable effect on the melting points, degree of molecular rotation and ease of rotation of the various isomeric compounds present.

Cairns and Eglinton⁽³⁶⁾ compared the infra-red stretching frequencies of a series of Novalaks in carbon tetrachloride solution. The presence of well defined intra-molecular hydrogen bonded monomers and inter-molecular hydrogen bonded dimers was clearly shown. Spectroscopic studies of bisphenol alkanes demonstrated the existence of cis, trans and inter-molecular bonded species.

Recently proton magnetic resonance spectroscopy⁽³⁷⁾ has provided evidence that benzyl type hemi-formals make a substantial contribution to the structure of many resoles. It is thought that these functionalities exhibit high stability under certain conditions of initial cure.

It was previously mentioned that the true extent of crosslinking is unknown. It was thought likely, however, that after a small amount of crosslinking has taken place, the network is too stiff to allow further reactive groups to come into a favourable position for

reaction. In bisphenol A resins steric hindrance is increased because of the larger and stiffer network unit. The molecule exhibits a higher functionality than phenol alone⁽³⁸⁾ and when less than 1 mole proportion of p-cresol is used, the crosslinking limit seems to increase. However, when a high proportion of p-cresol is incorporated into this system, the crosslinking density is reduced. This is probably a consequence of the lower functionality of the p-cresol molecule.

It has been shown that the degree of crosslinking present affects the thermal stability of phenolic resins⁽³⁹⁾. This is probably related to the degree of rotational freedom within the network. In a study⁽⁴⁰⁾ of the pyrolysis of a series of resins derived from aromatic hydrocarbons char yields increased proportionally with molecular weight. Crosslink density was controlled and the average number of methylene bridges determined.

Further studies⁽³⁸⁾ indicated that bisphenol A resins are less thermally stable than phenol derived resins. Substitution of the aliphatic hydrogen atoms of bisphenol A enhanced the thermal stability of the resin probably due to changes in the inter-nuclear bond length. However, eventually the results of degradation similarly produced low yields of carbon residue.

The crosslinking of p-substituted phenols is less readily understood since they are difunctional only. There is considerable doubt about the true facts of this matter. Workers^(41, 42) have suggested that the formation of p-methides in p-cresol resins provide sources of added functionality since the methide group is capable of polymerisation itself. Pritchett⁽⁴³⁾ has suggested a curing mechanism

whereby linear chains of p-cresol units become entangled to a sufficient degree to effect "hardening". Reaction at the meta position of the aromatic nucleus has also been suggested⁽⁴⁴⁾. It was thought that the inductive effects of para methyl and chloro groups activate this position rendering it susceptible to electrophilic attack. Finally it has been postulated⁽⁴⁵⁾ that the phenolic hydroxyl group participates in the curing reaction. There is limited experimental evidence to support any of these ideas, however. This area of the field will be examined further in a later section of the thesis.

3. 2. 5. PLASTICISATION.

The effect of "plasticisation" on the mechanical properties of phenolic poly-condensates has been discussed by Herman⁽⁴⁶⁾. He considers that the addition of inert plasticisers does not enhance to a great degree the resistance of elastic products. However, internal plasticisation effected by chemical reaction of the plasticising agent with the resin, or by the substitution of suitable groups on the aromatic ring gives a product capable of taking up deformation forces elastically and reversibly. Polyolefins, fatty acids, halogenated paraffins and low molecular polymers have been quoted as suitable plasticising agents.

The effect of substitution in the meta position of the ring on the punching properties of phenolic laminates has been studied by Freeman and Traynor⁽⁴⁷⁾. They conclude that branched chain substituents have the most effect since, beyond the second carbon atom in straight chains, the effect of steric hindrance becomes negligible. They found for example that a meta-isopropyl phenol

based resin gave a product exhibiting almost "perfect" punching properties.

It is thought that plasticising agents containing double bonds e.g. tung oil, react with o-hydroxymethyl groups to produce chroman rings (48, 49, 50). The existence of quinone methides is also considered likely. These ideas are represented by the scheme given in Figure 22.

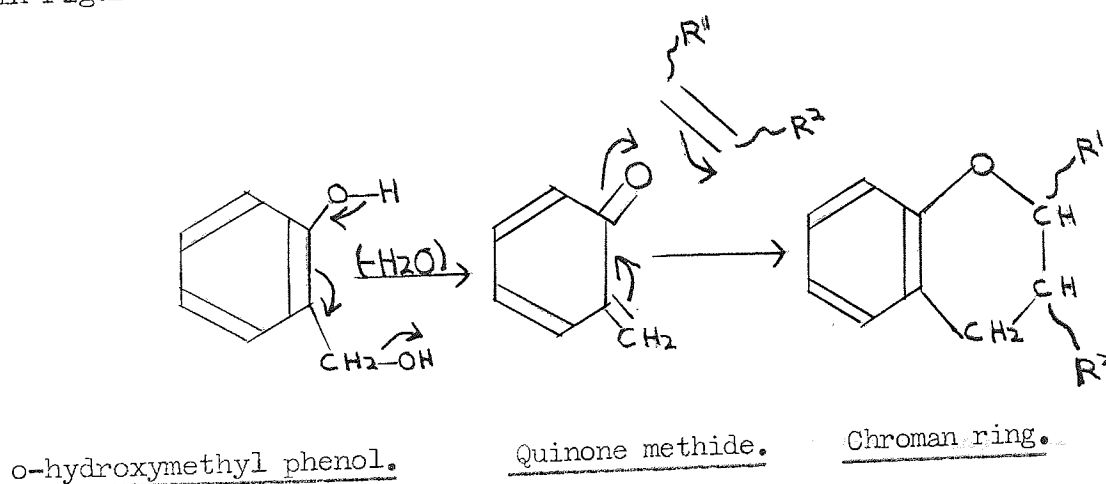

FIGURE 22. CHROMAN RING FORMATION.

Two reasons may be suggested for the plasticising effect of this type of reagent:-

1. The functionality of the resin is decreased and thus the cured resin will contain few crosslinks.
2. Phenolic hydroxyl groups are blocked. Hence potential sites for hydrogen bonding are removed and the resin will lose some of its inherent brittleness.

Workers (51, 52) have prepared various quinone methides and

demonstrated their ability to polymerise under oxidising conditions.

Cashew nut shell liquid (C.N.S.L.) has been successfully used as an internal plasticising agent⁽⁵³⁾. It has a dual functionality in resin forming reactions because it is both phenolic and olefinic in character. Preliminary investigations by Watson⁽¹⁾ suggest that C.N.S.L. modified resins give laminates with improved punching quality, probably due to enhanced flexibility.

3. 2. 6. SYNTHETIC WORK.

As might be expected from simple molecular considerations, it is extremely difficult to prepare a resin of known regular structure. It appears that even with carefully derived model systems the structure is at best only partially defined.

It is clearly more convenient to use "blocked" phenols as starting materials. However, we are warned by Lilley⁽⁵⁴⁾ that the use of such model systems may lead to erroneous results. He argues that methylene bridges rather than ether linkages will predominate in practice when technical materials containing free reactive positions are used.

The rational synthesis of phenol-formaldehyde resin intermediates has long been attempted with varying degrees of success⁽⁵⁵⁾. Notable workers in this field include Koebner, Zinke, Von Euler and Hultzsh. Although useful information has resulted from their efforts, the compounds synthesised differed from the actual resin intermediates formed in P/f condensation reactions. Thus doubt is cast on how far the results obtained with such compounds are applicable to the ordinary hardening processes which occur in commercial resins.

The inherent difficulties confronting rational synthesis of

genuine intermediates arise from the necessarily high reactivity of the molecules concerned. Frequently this renders isolation of products difficult on account of self-condensation.

The preparation and isolation of these intermediates often involves most laborious synthetic routes. The preparation of the resole illustrated in Figure 23 might be cited⁽⁵⁶⁾ as an example to illustrate this point. A summary of the reactions used in this synthesis is given below.

1. Oxidation of 2,2'-dimethoxy - 5-methyl diphenyl methane with potassium permanganate.
2. Demethylation with hydrobromic acid in acetic acid.
3. Reduction by the Martin-Clemmensen method.
4. Reduction with lithium aluminium hydride.
5. Isolation of the resole.

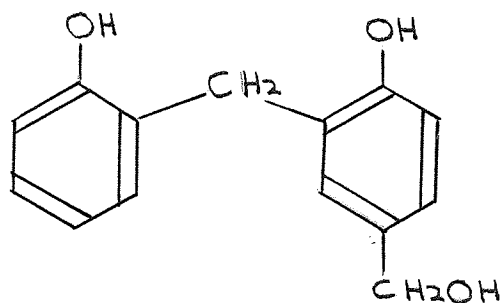

FIGURE 23. 2,2'-DIHYDROXY-5-HYDROXYMETHYL DIPHENYLMETHANE.

Linear polymers have been prepared by the condensation of p-alkyl phenols and p-alkyl derivatives of 2,6-dihydroxymethyl phenol⁽⁵⁷⁾.

Chain terminated linear systems were obtained by the use of 2,4 - disubstituted alkyl phenols. Molecular weight determinations were made by the ebullioscopic method of Menzies and Wright⁽⁵⁸⁾. o-p linked polymers were prepared from a o-chloro phenol/T.H.F./ formaldehyde mixture. A chlorine free product was obtained by dechlorination using a sodium/liquid ammonia system⁽⁵⁹⁾. o-o linked linear systems based on p-chloro phenol have been prepared and isolated in good yield by Burke⁽⁶⁰⁾. Fractional precipitation followed by viscosity studies indicated quite clearly the existence of multi fraction linear polymers. These exhibited a wide range of molecular weights. Hence it is readily understood that where the functionality exceeds two, structural definitions are extremely difficult. It is claimed by Kammerer⁽⁶¹⁾ that the condensation of 2,4,6 - tri (hydroxymethyl) phenol gives a three dimensional cross-linked polymer having a very regular uniform structure. However, preparative methods are not clearly outlined in his paper and, therefore, inevitably, this work must be treated with some caution. Doroshenko et al⁽⁶²⁾ prepared a series of resins based on long chain substituted paraffins. (See Figure 24).

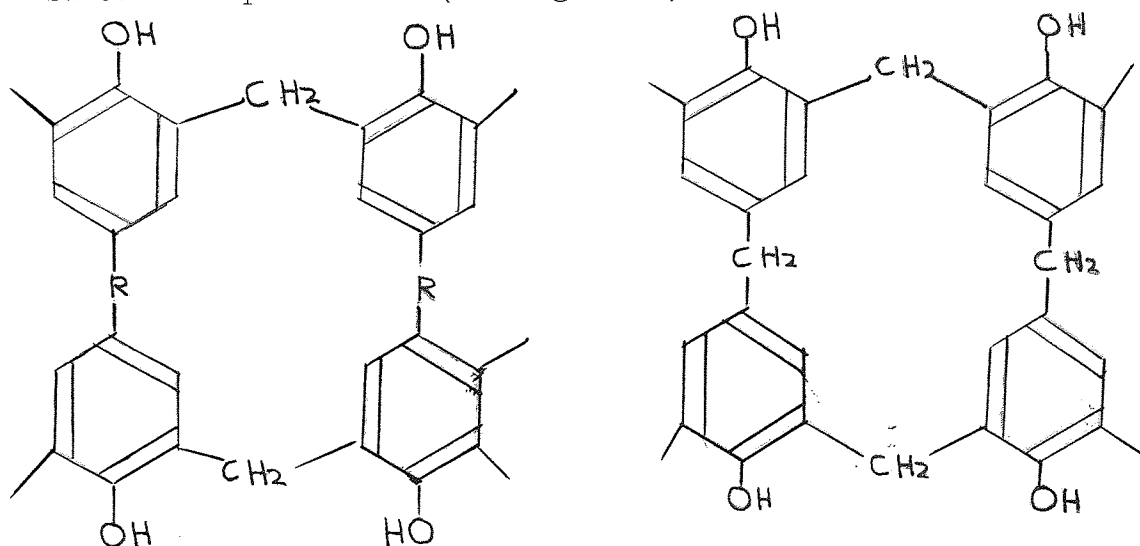

FIGURE 24. STRUCTURAL FORMULAE OF RESINS BASED ON SUBSTITUTED PARAFFINS.

Where: - R = $(-\text{CH}_2-)_6$; $(-\text{CH}_2-)_8$; $(-\text{CH}_2-)_10$.

These were used to demonstrate the effect of the length of the crosslink of the mechanical properties. They showed that when the number of methylene groups in the crosslinked network is increased, the products have better mechanical properties than normal phenol-formaldehyde polymers.

The synthesis of poly (hydroxymethyl) phenols in good yield has been achieved by Freeman⁽⁶³⁾. His work included the preparation of 2,4,6 - tri-(hydroxymethyl)-phenol in 79% yield by the direct condensation of phenol with formaldehyde. Melting point determinations and paper chromatography analysis indicated the presence of the pure compound only. The methylol content of these poly-(hydroxymethyl) phenols may be determined by the method of Martin⁽⁶⁴⁾. This method is rapid and gives an error of about 3%. A more accurate, slightly modified, technique has been described⁽⁶⁵⁾ for use when small samples only are available for analysis.

Carpenter and Hunter⁽⁶⁶⁾ prepared a series of phenolic compounds based on substituted alkanes. This work included the preparation of 1,3 - di-(o-hydroxyphenyl)-propane by an Aldol type condensation from o-hydroxy-aceto-phenone and salicylaldehyde. Yields were high and elemental analysis suggested a product of high purity.

3. 2. 7. FRIEDEL CRAFT POLYMERS.

Phillips and co-workers^(67, 68) showed that under Friedel Craft conditions p-dichloroxylylene and later p-xylene glycol dimethyl ether (X.G.D.M.E.) could be used generally in preparing heat resistant polymers with other aromatic compounds. The polymers were capable of crosslinking by the use of suitable aromatic substrate and

suitable choice of the Xylylene:substrate molar ratio.

Laminates made from these materials have good insulating properties and thus have found application in the electrical industry in the manufacture of coil winding formers.

The Friedel Crafts reaction involves the alkylation and acetylation of aliphatic and aromatic compounds in the presence of a Lewis acid. The reaction was first reported by Friedel Crafts in 1877⁽⁶⁹⁾. A series of reviews edited by Olah⁽⁷⁰⁾ gives an extensive coverage of the different aspects of the reaction.

Alkyl halides are the commonest alkylating agents although many other types of compounds may be used.

The overall reaction for alkyl halides and ethers with aromatic compounds may be represented as follows:-

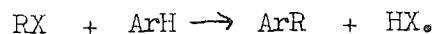

Catalyst activity depends on substrate, alkylating agent and solvent. For example aluminium chloride is active in a p-nitrobenzene solvent, but is ineffective in ethers, ketones and alcohols. Thus solvents containing deactivating groups such as nitro and chloro are used in Friedel Crafts reactions.

The presence of electron donating groups, such as hydroxyl activate the aromatic nucleus towards alkylation reactions. Electron withdrawing groups such as nitro, however, tend to deactivate the nucleus.

Brown and Grayson⁽⁷¹⁾ have suggested the following mechanism to account for the reaction between ethers and aromatic compounds:-

The lone pair of electrons on the ether oxygen atom may be

donated to a Lewis acid to form a complex. The O - C bonds are thus weakened and one of them breaks to give a carbonium ion. The following scheme might, therefore, be envisaged:-

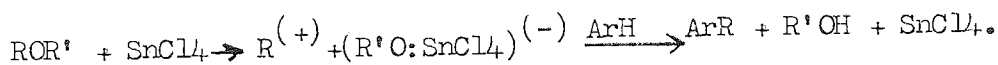

Following this the second R-O link may be split in a similar fashion.

X.G.D.M.E. cleaves to form a carbonium ion in the following way:-

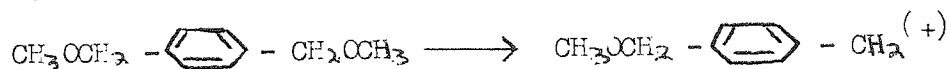

This process is then repeated following alkylation or may occur concurrently.

Friedel Crafts polymers prepared from polyarylene compounds⁽⁷²⁾, aromatic and dihalomethyl aromatic compounds⁽⁷³⁾ and dialkoxy methyl aromatic compounds have also been reported in the literature. However, to-date few applications for these polymers have been found.

Paxton⁽⁷⁴⁾ attempted to prepare a series of linear polymers based on X.G.D.M.E. He found that the system contained a substantial degree of crosslinking and the X.G.D.M.E. was capable of undergoing self-condensation during the reaction. This is explained on the basis that the X.G.D.M.E. aromatic nucleus contains four active positions which present potential crosslinking sites. It was, therefore, suggested that the use of a tetrasubstituted derivative of X.G.D.M.E. might be used to eliminate branching.

As a result of that work 2,3,5,6-tetrafluoro-1,4-dimethoxymethyl benzene was synthesised⁽⁷⁵⁾ to test this theory. (See Figure 25).

The monomer reacted with diphenyl oxide under Friedel Crafts conditions, but, unfortunately, no analytical details of the produce are given.

Recently⁽⁷⁶⁾ a new family of thermally stable thermosetting resins^{*}

* Trade name - XYLOK resins.

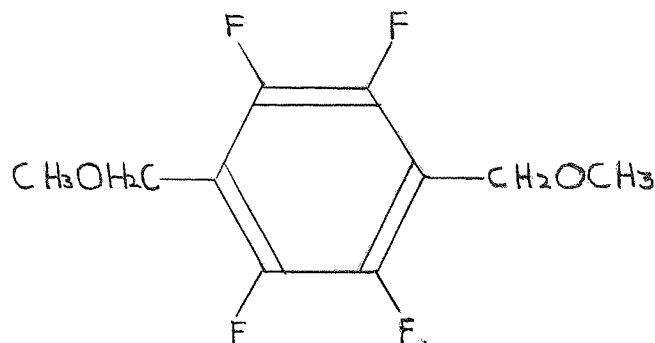

FIGURE 25. 2,3,5,6-TETRAFLUORO-1,4-DIMETHOXYMETHYL BENZENE.

have been prepared. These are based on the condensation products, aralkyl ethers or halides with phenols in the presence of a Friedel Crafts catalyst. They are fast curing and composites have been prepared using glass and asbestos based fillers. Mechanical strength and chemical resistance is said to be outstanding.

Friedel Crafts resins are usually slow curing, but by reacting phenol with X.G.D.M.E. a pre-polymer containing a built-in curing mechanism is obtained. The molecular weight of the pre-polymer is in the range 600 - 800. This may then be cured with hexamethylene tetramine by reaction at ortho and para sites on the phenolic nucleus. Figure 26 illustrates the overall reaction scheme.

The analogy with the phenol-formaldehyde novalaks is immediately recognised. No mention is made of a resole analogue of the prepolymer although there is no reason why this should not be possible.

3. 2. 8. EFFECT OF PAPER BASE.

Paper consists mainly of pure cellulose, together with small amounts of lignin and related materials (1.5 - 8.0% by weight)⁽⁷⁷⁾. Factors which affect paper strength are, fibre length, condition of

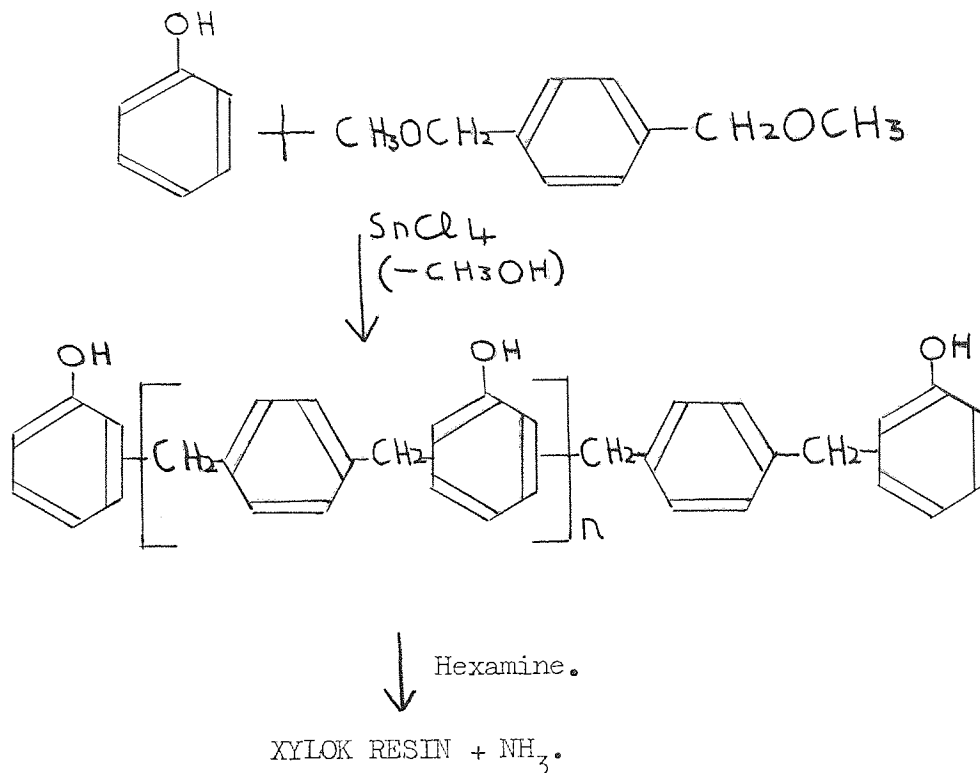

FIGURE 26. FORMATION OF XYLOK RESIN.

fibre surface (which affects fibre slippage), size of fibre and orientation of fibre. Most important, however, is the degree of fibre-fibre bonding which may include primary valence bonds, polar bond attraction, hydrogen bonds and interlocking surfaces. The predominating force arises from hydrogen bonds between hydroxyl groups in adjacent fibrillae. These are the specific source of interfibre bond energy and establish a continuous network in the paper. The presence of hemicellulose increases the strength per unit area of bond. The high lignin content results in poor interfibre bonding, low density, inferior strength and a reduction in flexibility.

Bleached Kraft paper consists of long fibres and, together with rag paper, constitutes the strongest paper in terms of tensile strength.

Absorption of hydrophobic materials such as rosin or silicones on the paper surface reduces the fibre-fibre bonding and hence the

hydrophilic nature of the fibre surface. The particular resin used is present in the laminate in sufficient quantity and is distributed in such a manner as to be regarded as the dominant component of the laminate with regard to the properties measured. The bursting and tensile curves for a series of papers with varying resin contents were very similar in appearance. If the resin content is increased a point is reached where the identity of the paper is minimal and the characteristics of the resin predominate. Hence the paper assumes the role of a carrier for the resin and as a shock absorber of a sort in the laminate. This property will be affected by three factors:-

1. Resin content.
2. Affinity of paper to resin.
3. Accessibility of the fibres to the resin.

The last factor will be closely connected to absorbancy, hence to the wetting action of a given resin on a given pulp and possibly comparability of a chemical nature.

--O-O-O-O-O-O--

CHAPTER 4.

MECHANICAL TESTING.

4. 1. INTRODUCTION.

In Chapter 3 some mechanical testing methods have been reviewed. In order to gain a greater appreciation of the basis on which these tests might be utilised, some theoretical considerations were mentioned. Finally, the relative merits of each test was discussed.

These methods were selected as a basis by which a more complete picture of the resin properties might be assessed. Further, it was hoped that this approach might provide useful information regarding the desirable properties of a good punching laminate.

It is therefore intended to describe in detail the testing techniques used in this work. The manner in which preheating facilities were developed and preheating times chosen will also be discussed.

4. 2. PUNCHING PROPERTIES.

In order that the programme of work outlined in Section 2.3. might be carried out within the permitted time scale, it soon became apparent that the instrumented procedure could not be achieved. In addition it was noted that although Watson's approach was interesting, interpretation of the stress-strain curves was difficult in terms of structure-property correlations. Further, the mechanics of these curves does not seem to be fully understood and thus a certain lack of confidence was felt about adopting this procedure. Therefore, punching properties were assessed on a qualitative basis only.

4. 2. 1. TESTING PROCEDURE.

Under the standard test conditions the test piece (which measured $4 \times 2 \times \frac{1}{16}$ in - 10.2 x 5.1. x 0.16 cm.) was placed in the heating block and transferred to a hot air oven at the desired temperature. After $9\frac{1}{2}$ minutes the heating block was removed from the oven and fixed onto the locating slots in the tool set and the spring mechanism was fitted. The test piece was punched after having been in the heating block for 10 minutes. Five standard samples of each laminate were punched at each testing temperature.

Punching quality was assessed as outlined in Section 3.1.5. The set of standards used were taken from Watson's thesis. In addition the type of defects seen in the test piece was classified. Their origins will be discussed in Section 9.3.

4. 3. FLEXURAL PROPERTIES.

4. 3. 1. INTRODUCTION.

The theory and relative merits of this type of loading has been outlined in Section 3.1.7. High speed shear properties are in part dependent upon the flexural components of the laminate. Thus it seemed that this type of test would provide useful information about the properties of a good (or poor) punching laminate. Finally it was thought that this type of loading might aid structure-property correlations in a more controlled fashion. A.S.T.M. standard D790-66 relating to three point loading tests was used as a basis on which all flexural properties were assessed in the present work.

4. 3. 2. DEVELOPMENT OF TESTING PROCEDURE.

To enable testing to be done over a range of temperatures, the three point loading jig was housed in a heating box (See Figure 27).

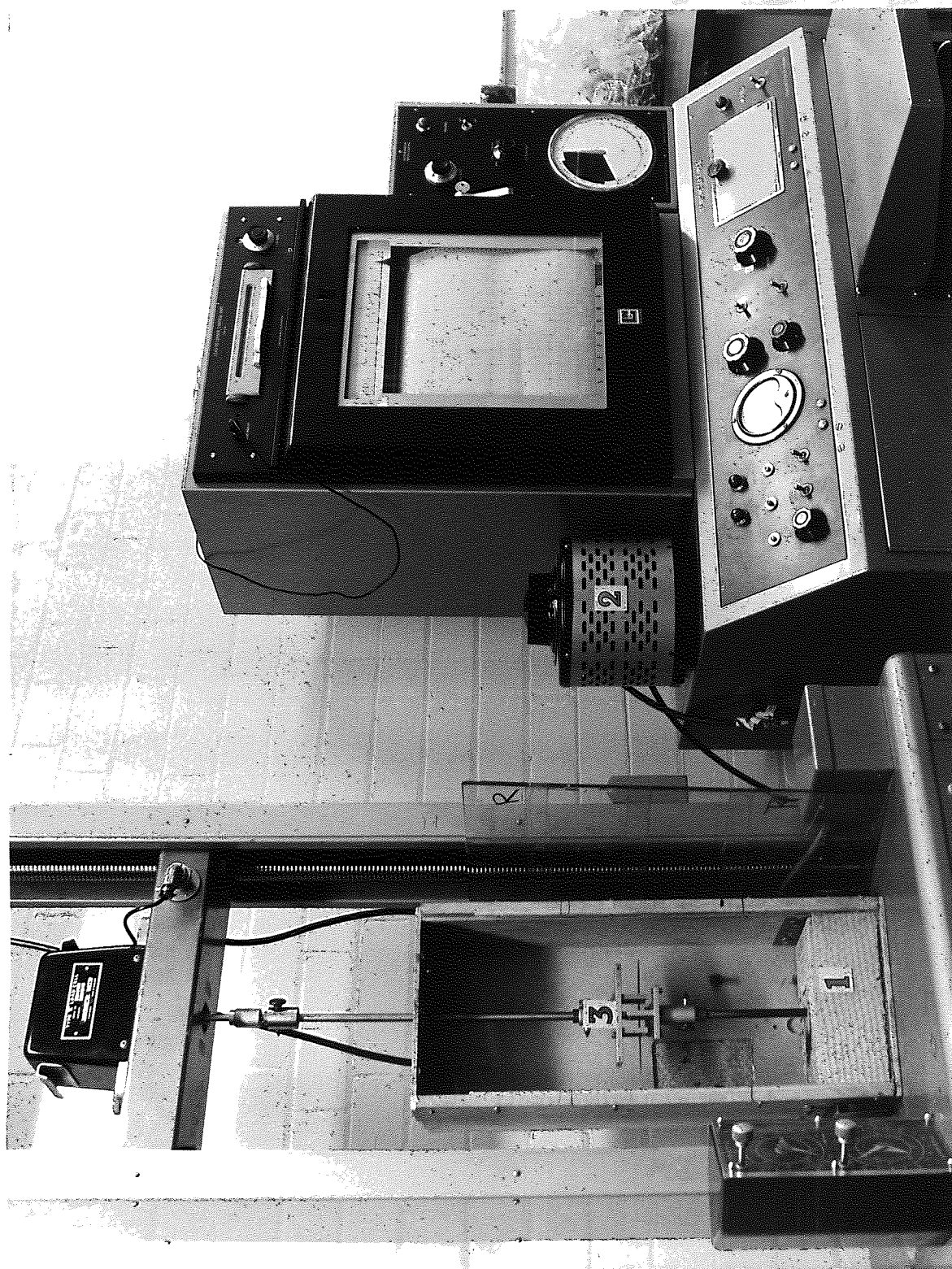

FIGURE 27. FLEXURAL TESTING EQUIPMENT.

1. Heating box.
2. Variac
3. 3 point loading jig.

This consisted of a glass fronted asbestos box, the lower compartment of which housed 2 x 1 kw heating elements coupled in parallel. The upper compartment was heated by a small electric fan situated in the lower compartment. Cold air was blown over the heating elements and through a baffled base plate to ensure good mixing in the upper compartment. Temperature was controlled with a variostat coupled to the heating elements. Temperature tolerance throughout the upper compartment was within $\pm 0.5^{\circ}\text{C}$ of the testing temperature, which complies with A.S.T.M. requirements.

Preheating time was assessed by comparing box temperature with the actual test specimen temperature at various intervals of time. The latter was determined with a "dummy" sample incorporating an iron-constan wire thermocouple at its neutral axis. The thermocouple was calibrated with a "moving spot" galvanometer against ice and boiling water reference standards. A plot of box temperature against "dummy" temperature indicated a sample equilibration time of 20 minutes.

4. 3. 3. TEST PROCEDURE.

A Hounsfield "E-type" Tensometer was fitted with the three point loading jig and heating box (See Figure 27). The jig and test specimen were pre-heated in the heating box for 20 minutes prior to testing. Testing was continued until the specimen ruptured or the strain level exceeded 5%, whichever occurred first. An automatic chart recorder included in the equipment enabled flexural modulus, strength and strain at break to be calculated according to A.S.T.M. definition. A summary of the testing conditions is outlined in table 2. Five samples of each laminate were tested at each temperature and the

average of the five results calculated.

TABLE 2. FLEXURAL TEST CONDITIONS.

| DEFINITION. | STANDARD CONDITIONS |
|--------------------------------------|-----------------------|
| Span between outer loading supports. | 38.1 mm. |
| Sample specification (nominal) | 101.6 x 19.1 x 1.5 mm |
| Span:depth ratio (nominal) | 25:1. |
| Rate of testing. | 1.27 mm/min. |
| Chart speed. | 2.54 cm/min. |
| Equilibration time. | 20 minutes. |

4. 4. INTERLAMINAR SHEAR PROPERTIES.

4. 4. 1. INTRODUCTION.

In order to investigate resin-paper interactions, it was decided to use a test whereby shear properties might be determined in a more controlled fashion than the punching test. The type of materials selected for this investigation were in any case unsuitable for punching. Also it was considered interesting to compare interlaminar shear strength data with the punching properties of some of the laminates described later in this thesis. Thus a note may be made of any correlation which might exist between the two methods of shear testing.

Bearing these points in mind a short beam shear test jig was selected for this work. Such a device has been developed in this University and this was made available to the project (see acknowledgements). The jig (see Figure 28) was designed with the

Hercules shear test⁽⁷⁷⁾ in mind and enables both shear and compressive properties to be determined at low straining rates.

4. 4. 2. DEVELOPMENT OF TESTING PROCEDURE.

It is well known⁽¹⁴⁾ that shear strength varies with the following factors:-

1. Span:depth ratio.
2. Rate of loading.
3. Temperature.

In order to choose a suitable span:depth ratio for these materials a preliminary investigation was carried out using a commercial laminate (see Appendix for details). The material was tested at a series of span:depth ratios at a straining rate of 1.3 mm/min. Five specimens (nominally 51 x 6.4 x 1.55 mm) were tested at each span:depth ratio chosen and the average value of the interlaminar shear strength noted.

Interlaminar shear strength (14) was calculated according to the relationship:-

$$\tau = \frac{3P.}{4A.} \quad \text{N/m}^2$$

Where:-

P = load at break.

A = cross sectional area.

τ was plotted as a function of span:depth ratio as shown in Figure 29. At span:depth ratios exceeding 2.0 the specimen apparently had two values of break. The first break was ascribed to shear failure and the second to compressive failure. Below 2.0 one break only was observed and this was apparently caused by compressive failure. Figure 30 illustrates the observed differences in samples

which have failed in flexure, shear and compression respectively. It will be noted in Figure 29. that τ increases linearly as span:depth ratio decreases. However, below a span:depth ratio value of 2.0 there is a rapid increase in τ suggesting a different mode of failure.

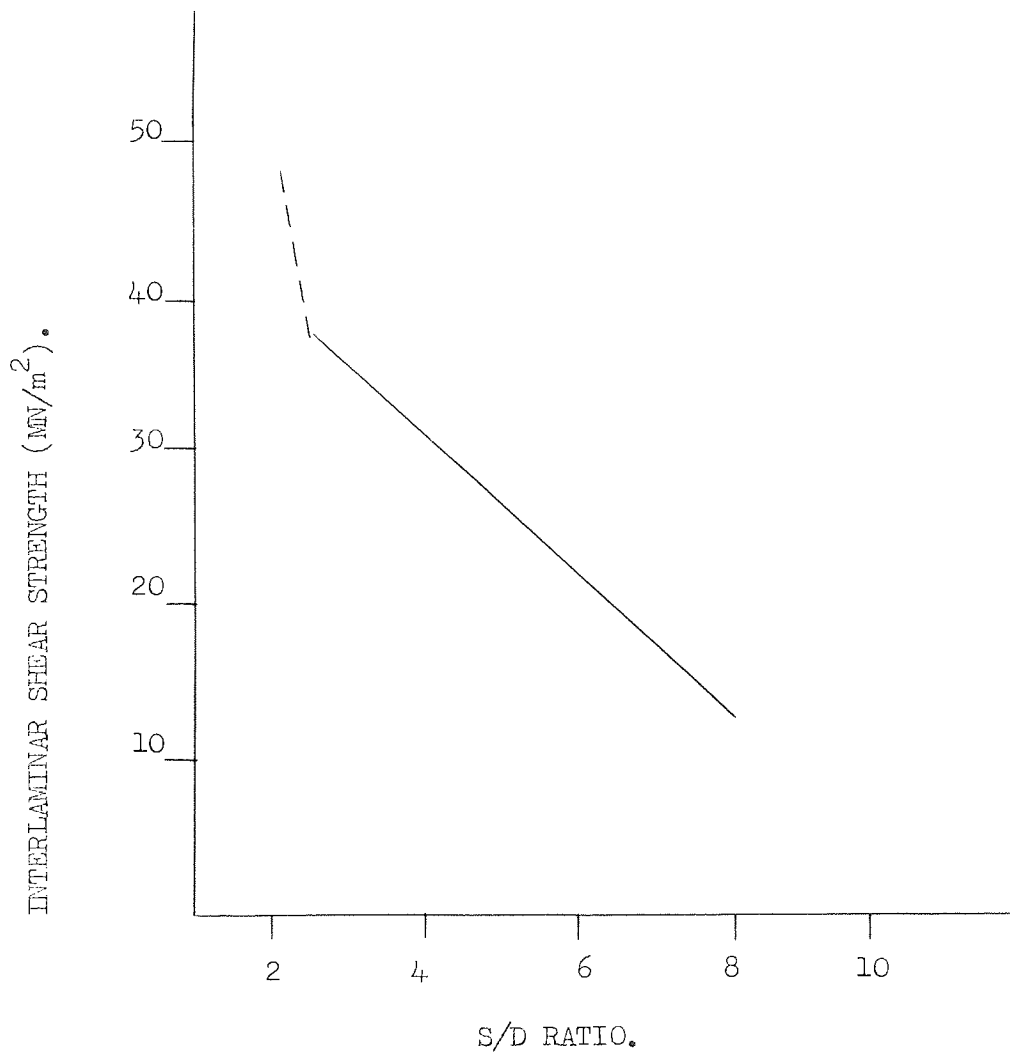

FIGURE 29. VARIATION OF INTERLAMINAR SHEAR STRENGTH WITH SPAN TO DEPTH RATIO.

4. 4. 3. TEST PROCEDURE.

Therefore, a span:depth ratio of 2.5 was chosen since this appeared to encourage shear failures whilst reducing flexural components to a minimum. The first load to break was taken for the value of P in equation 7 whilst the second compressive failure load which is a feature of shear testing was ignored. The initial rate of straining and sample specification was retained as standard conditions. Testing at elevated temperatures was carried out as described in Section 4.3.2.

It must be noted at this point that shear modulus cannot be determined by this particular method.

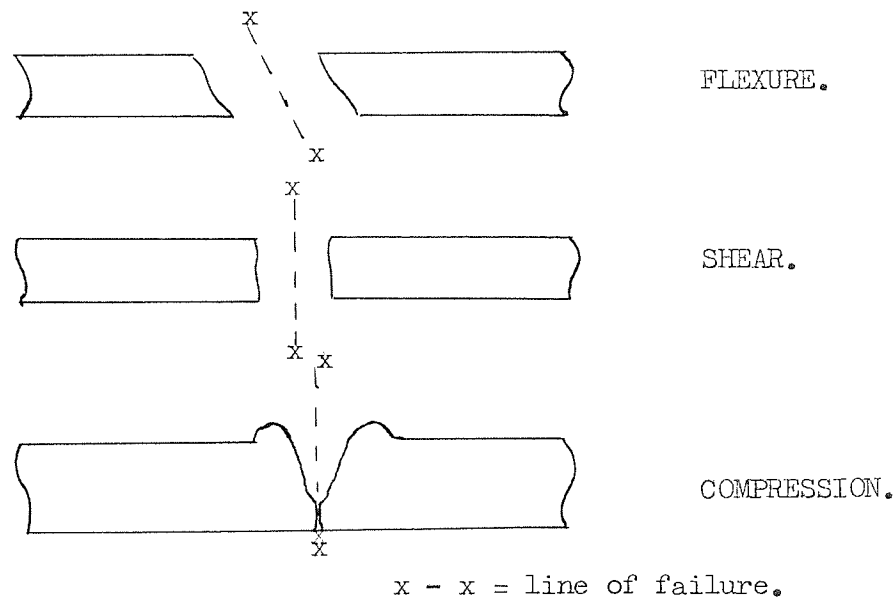

FIGURE 30. FAILURE MODES IN LOADED LAMINATE.

4. 5. DYNAMIC MECHANICAL PROPERTIES.

4. 5. 1. INTRODUCTION.

In Chapter 3 it was demonstrated that dynamic mechanical measurements provide a powerful tool in assessing the effect of structural features on polymer physical properties. Further, the

point was made that the torsional pendulum offers a simple method for investigating these relationships.

In this project resins incorporating different structural features are used in an attempt to explore structure-property relationships in paper-based phenolic laminates. It is considered that the use of the torsional pendulum might provide two valuable contributions to this work:-

1. Provide detailed information regarding structure-property relationships in this field.
2. Generate a deeper understanding of the variables involved which might affect punching properties.

The evaluation of dynamic shear modulus, G , (a function of rigidity) and mechanical damping, logarithmic decrement, Δ , (a measure of material toughness) are readily available with this instrument.

In view of these observations, the scope of mechanical testing was extended to include the use of the torsional pendulum.

4. 5. 2. DEVELOPMENT OF TESTING PROCEDURE.

The general method of testing and evaluation of results has been outlined in sufficient detail in Chapter 3.

To enable testing to be done over a wide range of temperatures, it was necessary to acquire a heating source capable of achieving at least a testing temperature of 160°C . The literature⁽⁷⁸⁾ mentions the use of thermostatted nitrogen gas capable of achieving test conditions within the range $0^{\circ} - 200^{\circ}\text{C}$. However, the construction and maintenance of a device achieving such a facility was considered unnecessarily tedious and costly. A popular form of heating consists

of blowing compressed air through a thick glass walled cylinder containing a heated element bar. This type of equipment is by no means robust and heat losses tend to be high leading to long sample equilibration times.

The heating box illustrated in Figure 31 was constructed to overcome these objections. This consisted of a thick walled 'Sindanyo' tube containing a 1 kw heating element. The relatively small "dead volume" and the use of baffles adjacent to the inlet and outlet pipes provided good temperature distribution throughout the box. Compressed air at $50\text{dm}^3/\text{min.}$ was blown through the heating chamber. The heating element was coupled to a variost^{at} enabling sensitive temperature control to be achieved. In operation the heating unit could be efficiently controlled within the desired temperature range ($20 - 160^\circ\text{C}$). Sample equilibration time was determined as before (see Section 4.3.2.) using a dummy sample clamped between the testing supports.

4. 5. 3. TEST PROCEDURE.

The "Nonius" torsional pendulum used in this work is illustrated in Figure 32. The testing conditions summarised in Table 3 were used in all dynamic mechanical measurements.

TABLE 3. CONDITIONS OF TESTING WITH THE "NONIUS" TORSIONAL PENDULUM.

| DEFINITION. | STANDARD CONDITION. |
|---------------------------------|--------------------------------------|
| Sample specification. | (102 x 13 x 1.6)mm. |
| Specimen length between clamps. | Approx: 5 cm. |
| Moment of inertia or crossbar. | $1.55 \times 10^5 \text{dynes/cm}^2$ |

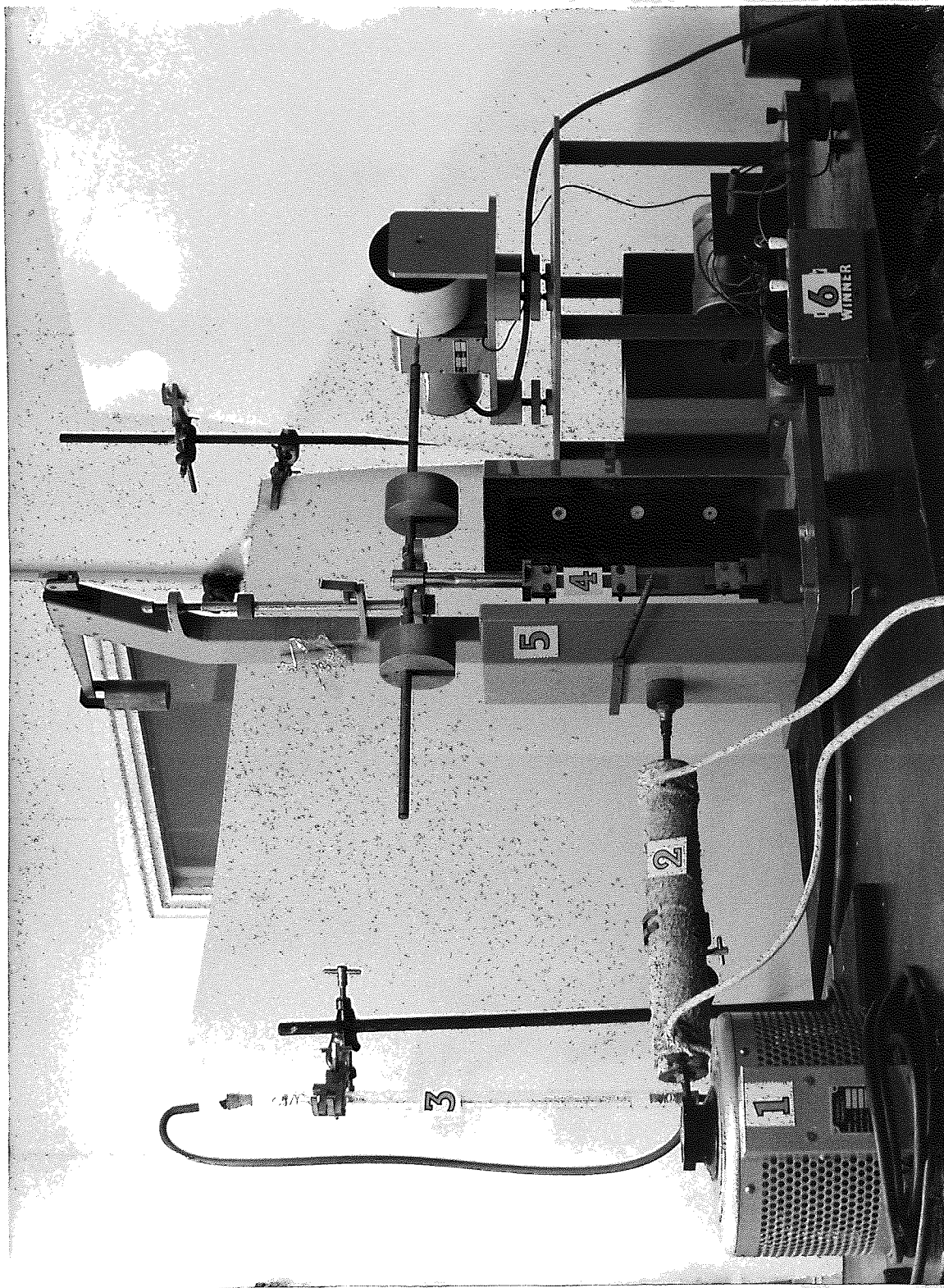
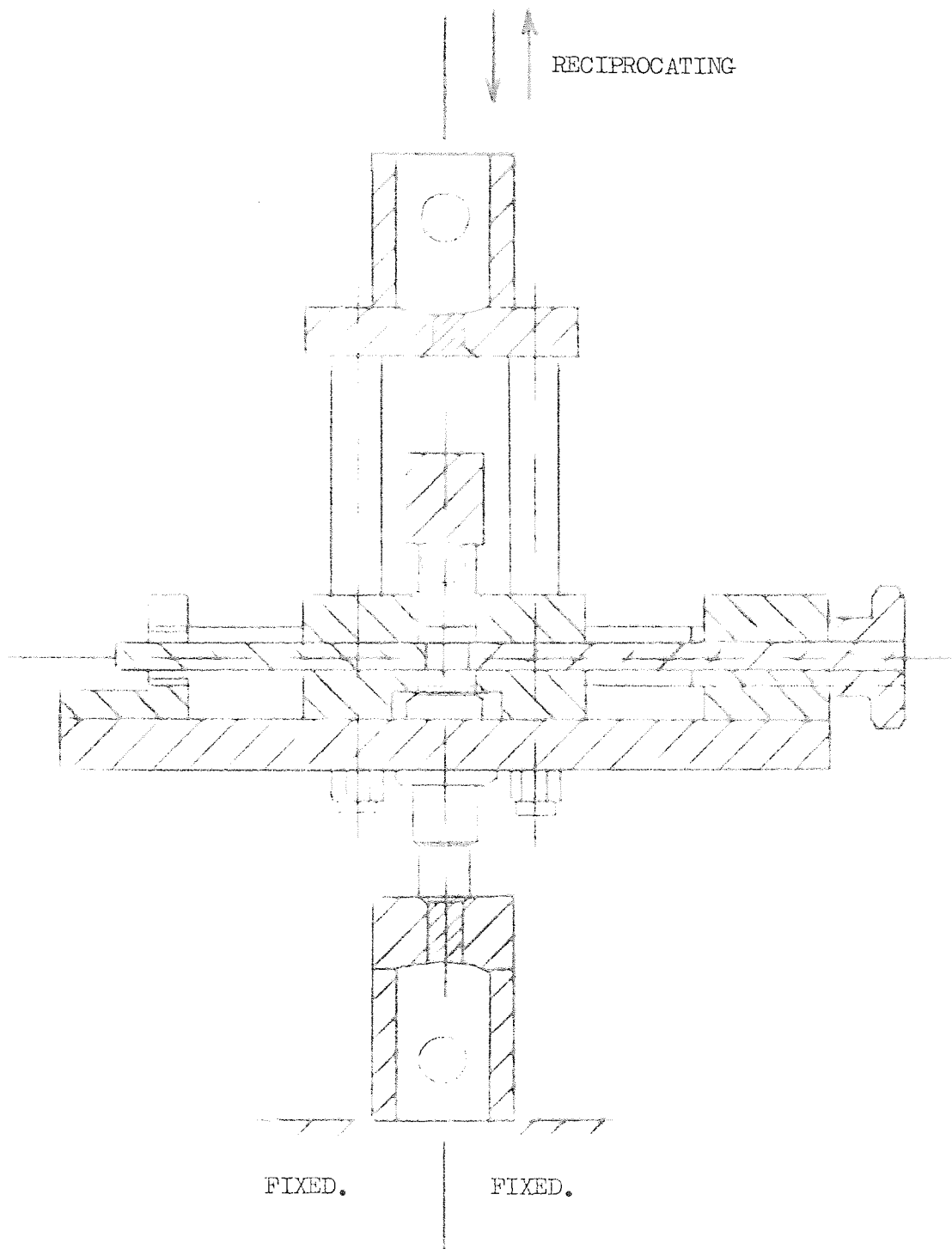

FIGURE 32. NONIUS TORSIONAL PENDULUM.

- | | |
|-----------------|--------------------|
| 1. Variac. | 4. Sample. |
| 2. Heating box. | 5. Sample housing. |
| 3. Flow meter. | 6. D. C. supply. |



SCALE DRAWING (FRONT VIEW).

FIGURE 28. SHORT BEAM SHEAR JIG.

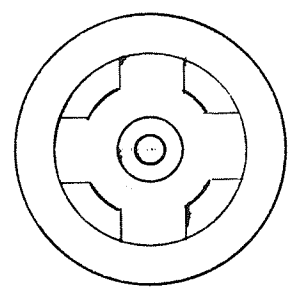
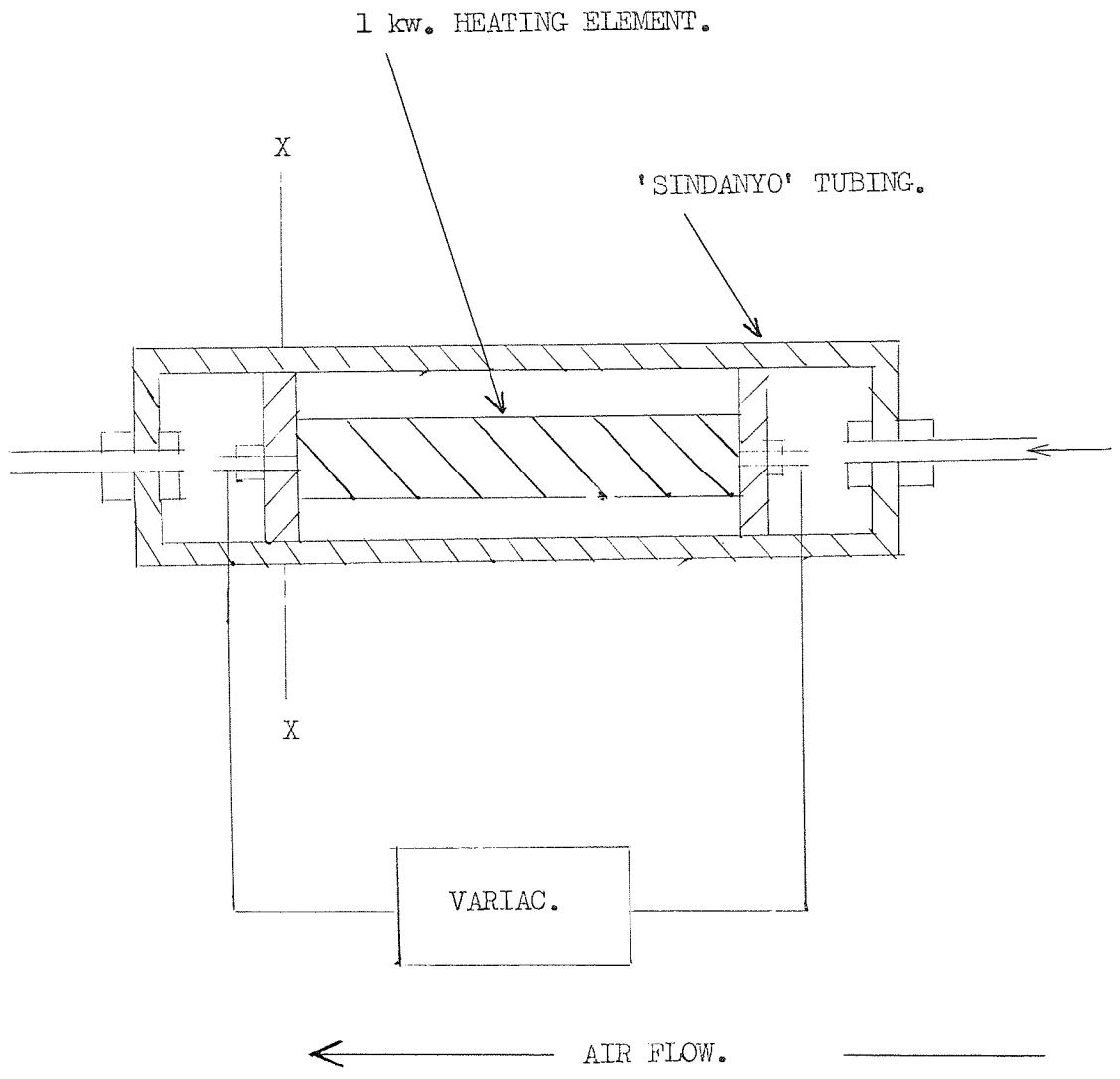

SECTION THROUGH X - X.

CHAPTER 5.EFFECT OF CROSSLINK DENSITY.5. 1. INTRODUCTION.

In view of Watson's⁽¹⁾ work, it appears that the number of crosslinks present in the cured resin will strongly influence the following structural features:-

1. Segmental motion.
2. Main chain stiffness.
3. Rotational freedom about methylene bridges.

Further, it is clear that these features will influence the degree of flexibility in the laminate and that punching quality is partly dependent upon this. Thus it seems reasonable that if the number of crosslinks present are controlled, then a comparison between molecular flexibility and mechanical properties may be obtained. In order to assess this correlation in a controlled fashion, it was considered necessary to examine a series of resins incorporating a known measure of crosslink number.

If p-cresol is considered as a difunctional entity in resin forming reactions condensation with formaldehyde should produce linear polymer chains. It should be possible to crosslink these chains with varying amounts of tri-functional phenol thus achieving a measure of the number of crosslinks present.

Reference to the literature illustrates the uncertainty which exists regarding the influence of para substituents on the course of initial condensation and curing reactions. Thus, a preliminary work programme was set up in order to gain a clearer picture of this problem.

Resins based on the systems given in table 4 were chosen for this investigation.

TABLE 4. SUMMARY OF PRELIMINARY WORK.

| RESIN. | CONSTITUTION. | AROH:CH ₂ O (MOLAR RATIO) |
|--------|--|---|
| A | p-cresol. | 1 : 1.12. |
| B | p-chlorophenol. | 1 : 1.12. |
| C | p-cresol/2,6 x ylenol(3:1 molar ratio) | 1 : 1.12/1:1. |
| D | p-chlorophenol/2,6 x ylenol(3:1 molar ratio) | 1 : 1.12/1:1 |
| E | p-chloro phenol/phenol(3:1 molar ratio). | 1 : 1.12/1:1.45 |

5. 1. 1. EXPERIMENTAL.

Resins were prepared in the glass apparatus illustrated in Figure 33 by refluxing the phenolic compound with aqueous formaldehyde (37%^W/W) in the presence of barium hydroxide (4 gm per mole phenol).

Reflux return was analysed for formaldehyde content by the method of Walker (See Appendix 1). Refluxing was continued until formaldehyde content fell below 0.5%^W/W or until a constant value was obtained. The catalyst was neutralised with sulphuric acid (10%^W/W) and the water removed at 30°C/10 mm until a clear viscous resin was obtained. At this point there was a corresponding increase in temperature to about 35°C. The resin was dissolved in DMS to give a resin content of 50% solids (See method in Appendix 1.). Bleached Kraft paper was impregnated by manually dipping in a small flat aluminium tray. The impregnated paper was dried at 85°C to give a volatile content of 5-10% and a resin content of 45%. Laminates were made by pressing

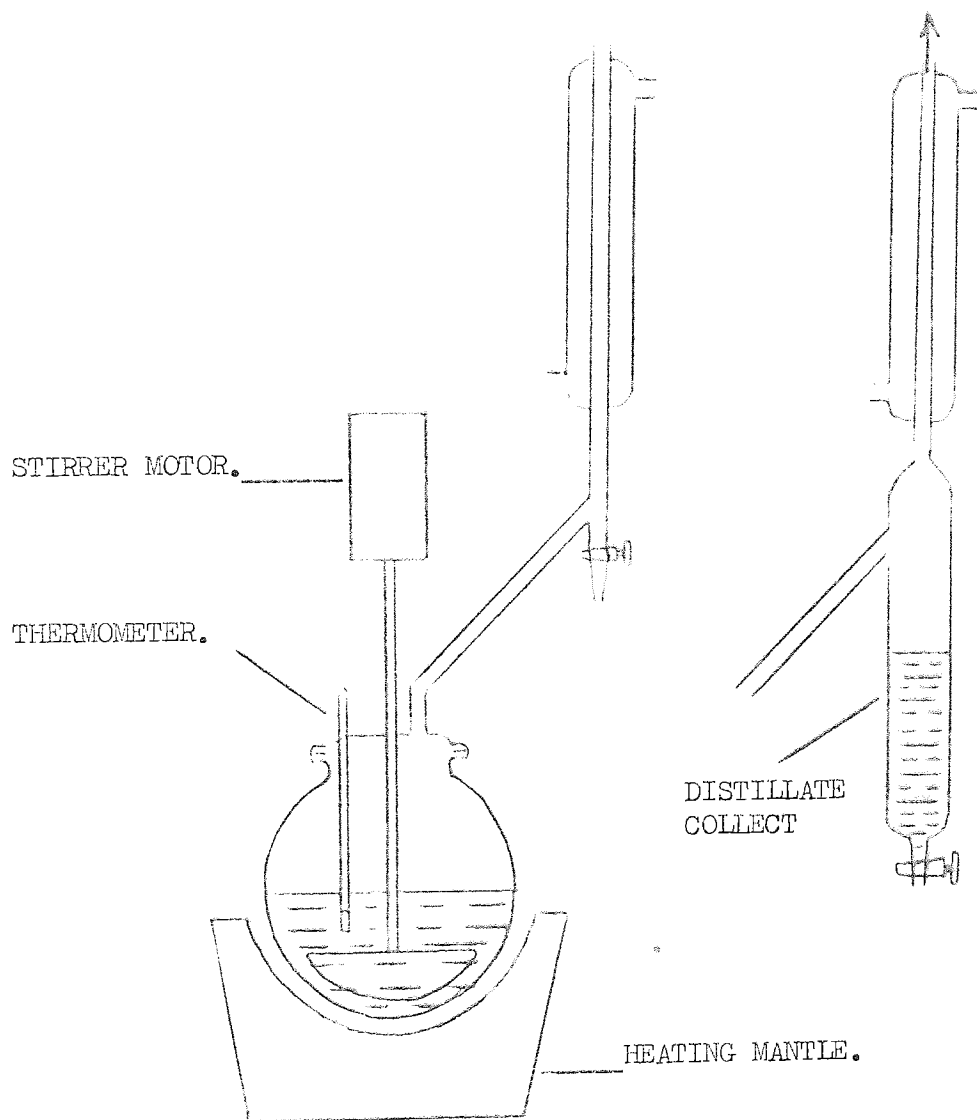

FIGURE 33. RESIN STILL.

unidirectional stacked sheets (6 ply) of impregnated paper at 150°C/1000 p.s.i. ($6.9 \times 10^8 \text{ N/m}^2$) for 60 minutes in a manually operated Apex press.

Samples for tensile testing were cut from the strong direction of the board with an electric bandsaw. Sample specification was nominally 102 x 19 x 1.6 mm. Testing was done with an E-Type Hounsfield tensometer fitted with a "Iton" tensile test jig at a straining rate of 10 inches per minute (25.4 cm/min). Test results are given in Table 5.

TABLE 5. TENSILE TEST RESULTS FOR p-SUBSTITUTED RESINS.

| RESIN. | ULTIMATE TENSILE STRENGTH (N/m^2) | CHARACTERISATION OF LAMINATED BOARD |
|--------|--|--|
| A | 1.86. | Pale yellow, exhibiting extensive delamination. |
| B | - | Black, extensive delamination. Too weak to test. |
| C | 5.72. | Pale yellow, delaminated readily by the application of manual pressure. |
| D | - | Similar to resin B. |
| E | 9.30. | Black, brittle, appeared to have a stronger interlaminar bond than resins A.B.C.D. |

5. 1. 2. DISCUSSION.

It must be emphasised that since only one mechanical property was measured here, possible conclusions must be regarded with caution

at this stage. The following points, however, may be tentatively inferred from the results given in table.5.

1. p-cresol alone crosslinks (chemically or physically) to a very low degree.

2. p-chlorophenol apparently has no crosslinking properties.

3. Incorporation of 2,6-xylenol adds strength to the p-cresol laminate.

4. Phenol adds considerably to the strength of the p-cresol laminate (i.e. exhibits its expected crosslinking potential by virtue of its trifunctionality.

5. Methyl groups bonded to the aromatic nucleus in resin C apparently aid resin hardening properties. Two mechanisms might be suggested at this point to explain this facility. (See A and B below).

A. Quinone methide formation.

B. Steric contributions.

A. It is known^(41, 42) that quinone methides are capable of polymerisation. Thus the existence of these intermediates may lend further crosslinking routes to the resin during the conditions of cure.

B. The bulkiness of the methyl group may enhance entanglement of the polymer chains leading to an apparently hardened system.

6. It would seem apparent from the p-chlorophenol resin that the chlorine atom neither aids entanglement nor activates the meta position to a sufficient degree to allow electrophilic attack at this position.

5. 2. PHENOL/p-CRESOL SYSTEM.

In view of the work described in Section 5.1.1. it was decided that the p-cresol-phenol system could be used to some advantage in this particular investigation. A small programme of work was, therefore, set up in order to gain a deeper understanding of the system before the main programme of work was carried out. Resins (See Table 6) were prepared incorporating varying molar ratios of phenol and p-cresol. Preparative details are similar to those described in Section 5.1.1. Observations made during these investigations are outlined below.

TABLE 6. PHENOL/p-CRESOL RESINS USED IN PRELIMINARY INVESTIGATION.

| RESIN. | PHENOL/p-CRESOL MOLAR RATIO. | MOLE% PHENOL. |
|--------|---------------------------------|------------------|
| F. | 1:0. | 100 |
| G. | 3:1. | 75 |
| H. | 1:1. | 50 |
| I. | 1:3 | 25 |
| J. | 0:1. | 0 |

1. The reaction of phenol alone with formaldehyde is essentially complete after 60 minutes refluxing.

2. The viscosity of the phenol/p-cresol resins visibly increased rapidly after 60 minutes refluxing. At this point about 2/3 of the initial formaldehyde content had been consumed. Further it was noted that if refluxing was continued for an additional 30 minutes, the

resin gelled with no further uptake of formaldehyde.

It seems likely that after 60 minutes refluxing p-cresol alcohols begin to condense to form polymer chains. Gelling is probably brought about by reaction of these chains with reactive para positions of mono and dialcohols of phenol with subsequent increase in molecular weight as crosslinking proceeds.

3. Samples of reflux return were taken at regular intervals of time during the condensation reaction. Plots of reflux against reaction time are given in Figure 34.

The results shown in Figure 34 display the expected course of behaviour. It is known⁽⁷⁹⁾ that phenol shows a greater reactivity towards formaldehyde than p-cresol due to the availability of the highly reactive para position in the former. Thus reaction rate increases with phenol/p-cresol ratio.

These findings gave some indication of the practical difficulties which might be encountered in the phenol/p-cresol system. It was now possible to repeat this work on a scale suitable for a fuller investigation to be made on this structure-property relationship.

5. 3. PREPARATION OF PHENOL-p-CRESOL LAMINATES.

5. 3. 1. EXPERIMENTAL.

A series of resins (See Table 7) were prepared on a 7 molar scale using the technique and apparatus outlined in Section 5.1.1. Reflux time was limited to 60 minutes in each case.

Bleached Kraft paper was impregnated once with a 50% resin content solution and once with a 25% solution to give a paper-resin content of about 45%. Impregnation was done with a laboratory scale continuous impregnater which is illustrated in Figure 35.

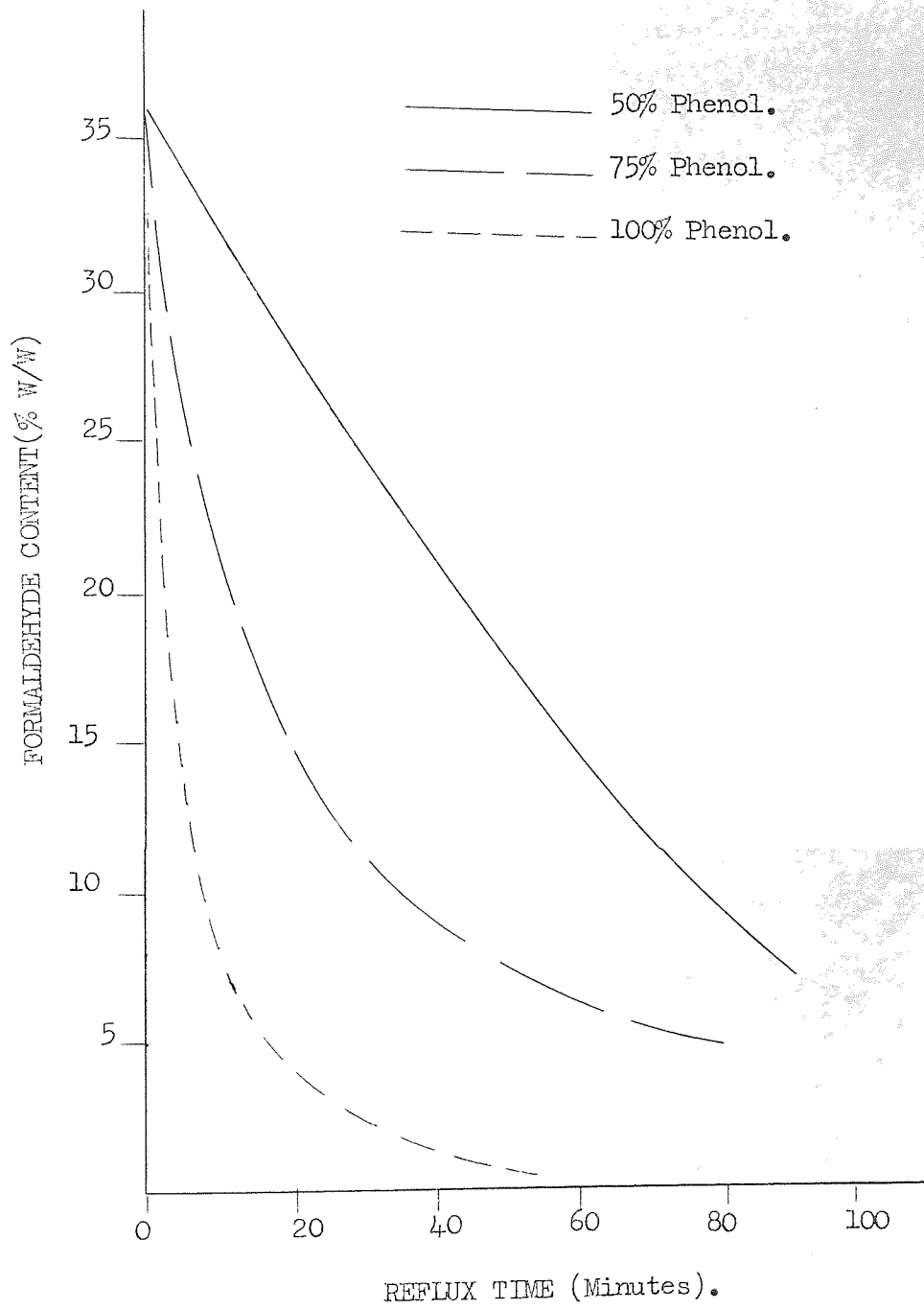

FIGURE 34. UPTAKE OF FORMALDEHYDE AS A FUNCTION OF TIME.

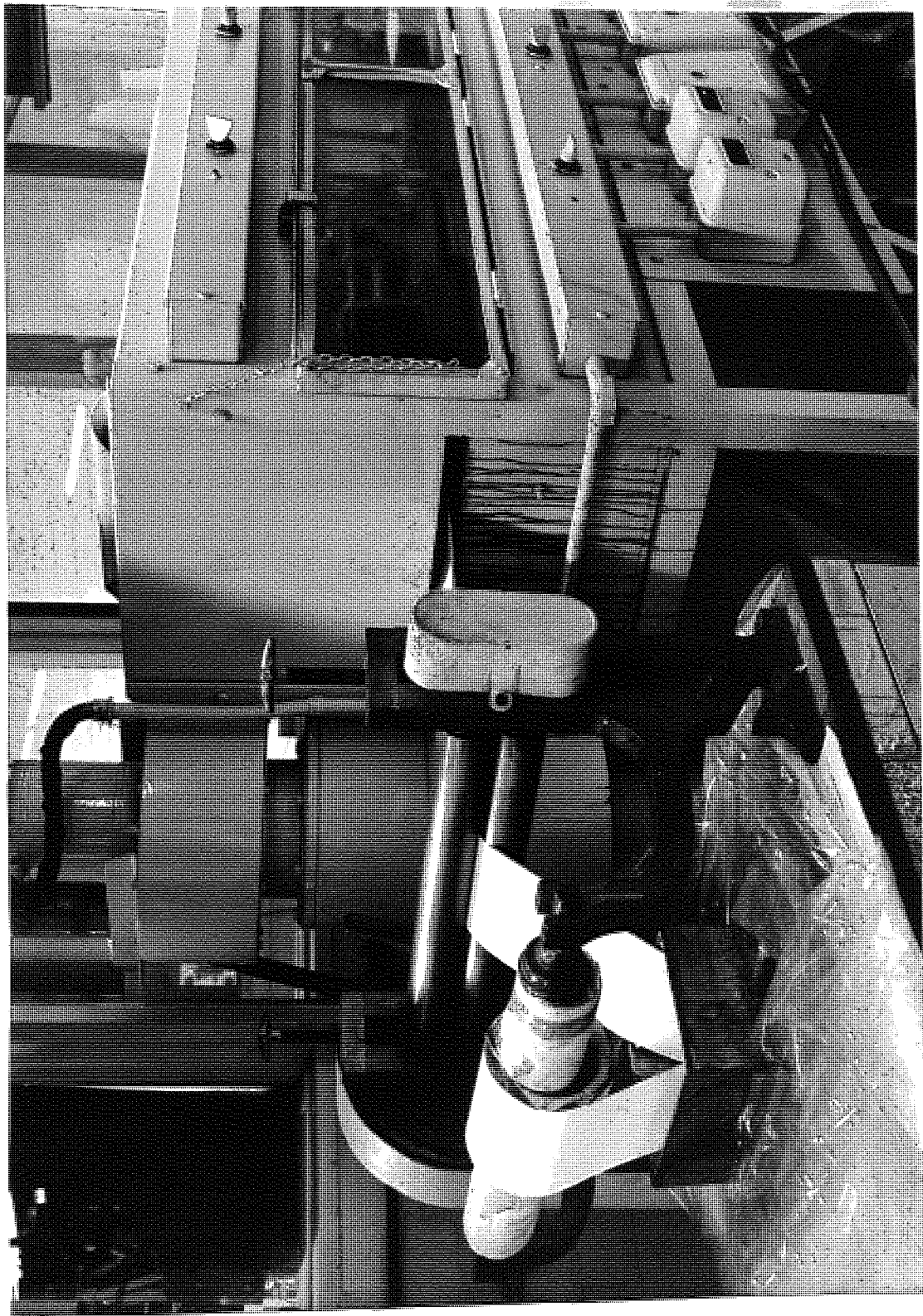

FIGURE 35. LABORATORY SCALE CONTINUOUS IMPREGNATER.

The drying air oven was controlled at between 100 - 105°C to flash off most of the solvent. Residence time in the oven at any given point on the paper was 105 seconds. The impregnated paper was dried in a forced draught air oven at 85°C for the required length of time (see below).

The dried paper was then cut into sheets measuring 5" x 10" (12.7 x 25.4 cm.). The sheets, 8 or 9 ply, were unidirectionally stacked and pressed between matt finish stainless steel plates in a 100 ton hydraulic press equipped with electrically heated/water cooled platens. Five sheets of newspaper were used as a pad between each plate and press platen. One sheet of Melinex was used between the plates and impregnated stacked paper to facilitate easy removal of the laminated board. The standard pressing conditions used in each case were 150°C, 1000 p.s.i. (6.9 MN/m²) for 60 minutes followed by cooling under pressure to room temperature over 20 minutes. It was found that this practice reduced warpage of the laminate considerably. Fuller details of processing conditions are given in Appendix 2.

TABLE 7. PHENOL-*p*-CRESOL RESINS USED IN LARGE SCALE INVESTIGATION.

| RESIN. | PHENOL: <i>p</i> -CRESOL MOLAR RATIO. | MOLE % PHENOL |
|--------|--|---------------|
| K. | 1:7 | 12.5 |
| L. | 1:3 | 25.0 |
| M. | 1:1 | 50.0 |
| N. | 3:1 | 75.0 |
| O | 7:1 | 87.5 |
| P. | 1:0 | 100.0 |

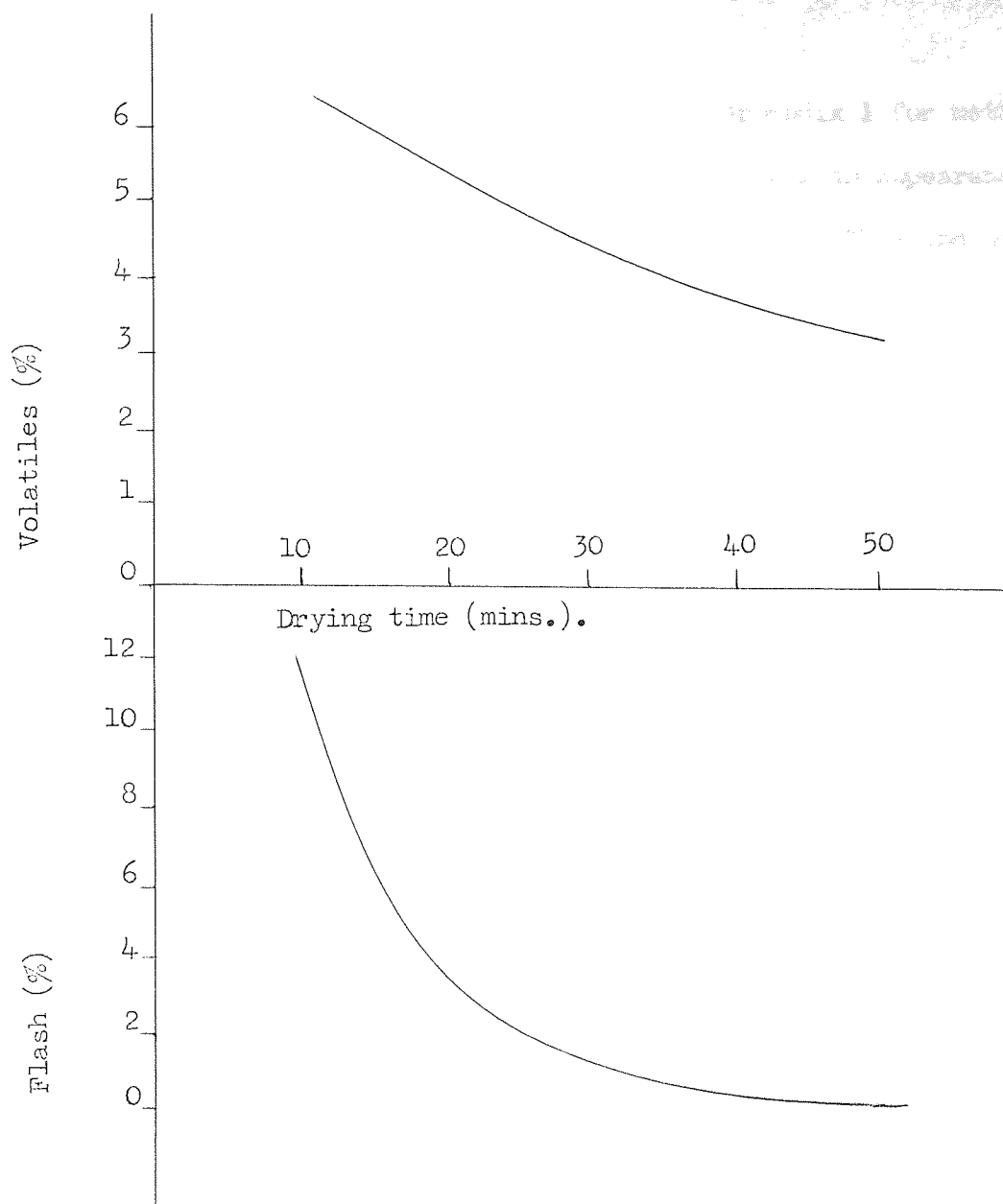

FIGURE 36. THE EFFECT OF DRYING TIME AT 85°C.

5. 3. 2. DRYING TIME EXPERIMENTS.

Since different resins were used on the same paper type, it was decided to follow Watson's practice of controlling the drying time as a function of resin flow characteristics. Therefore, for each system a piece of impregnated paper was dried at 85°C and samples were taken at regular intervals of time. These were used to make small laminates and examined for defects such as resin deficient areas. The paper samples were further assessed in terms of resin

content, volatile content and flash value (see Appendix 1 for methods). the required drying time gave a laminate, homogeneous in appearance and capable of being snapped in two by hand pressure. This indicates that the resin flow properties are suitable to present a good inter-laminar bond. The remaining bulk of the paper was then dried under these predetermined conditions. Figure 36 presents a typical set of data to show the variation of volatile content and flash value as a function of drying time.

5. 4. MECHANICAL PROPERTIES OF PHENOL | p-CRESOL LAMINATES.

It may be seen in Chapter 3 that there are several useful mechanical testing methods available which may be utilised to assess laminate properties.

Thus it was decided to examine these materials under the following types of loading:-

1. Flexure (3 point loading).
2. Dynamic (low frequency stressing).
3. Static shear (short beam).
4. Punching (high speed shear).

These tests should lend more information about the resin structure in a more controlled fashion than punching alone. In addition it was hoped that it might be possible to present correlations between punching data and other mechanical properties.

Testing specimens were obtained from the strong direction of the board and were carefully sand papered to give smooth edges. Tolerance was within $\pm 0.4/\mu\text{m}$. along the length of the specimen. Nominal sample specifications were as follows:-

1. Flexure = $(4 \times \frac{3}{4} \times \frac{1}{16})"$ or (101.6 x 19.1 x 1.55 mm.)
2. Dynamic = $(5 \times \frac{1}{2} \times \frac{1}{16})"$ or (127 x 12.7 x 1.55 mm.)

$$3. \text{ Static shear} = \left(2 \times \frac{3}{8} \times \frac{1}{16}\right)'' \text{ or } (51 \times 9.5 \times 1.55 \text{ mm.})$$

$$4. \text{ Punching} = 4 \times 2 \times \frac{1}{16}'' \text{ or } (101.6 \times 51 \times 1.55 \text{ mm.}).$$

Testing was done as outlined in Chapter 4 over a series of temperatures. Five samples were tested at each temperature for each resin, except the dynamic test in which only one specimen was tested for each resin. Results are tabulated in Appendix 3.

5. 4. 1. DISCUSSION OF RESULTS.

From Figure 37 it may be seen that both strength and stiffness increases to a maximum between 50 and 25% p-cresol, but the only major effect is the rapid decrease in flexural strength at 120°C as the proportion of either p-cresol or phenol is increased. Strain at break decreases steadily, but has nearly become constant at low cresol content. From Table 8 it is noted that punching quality steadily improves with increase in the p-cresol/phenol molar ratio. Punching quality exhibits its expected dependence upon temperature. These results will now be examined in greater detail, each property being treated separately.

5. 4. 2. FLEXURAL PROPERTIES.

The results of the flexural property experiments described are fairly straightforward and can be explained on the basis that at about 50% content of cresol in the phenols used some changes take place. Most of the curves are rather flat and the peak positions cannot be clearly established. The change may be either a maximum in the number of crosslinks or a minimum in the freedom of rotation around the bonds between methylene and aromatic groups. It is not, however, clear how the presence of p-cresol would change the flexibility of the network, as the geometry of the two phenols is rather similar and the pendent

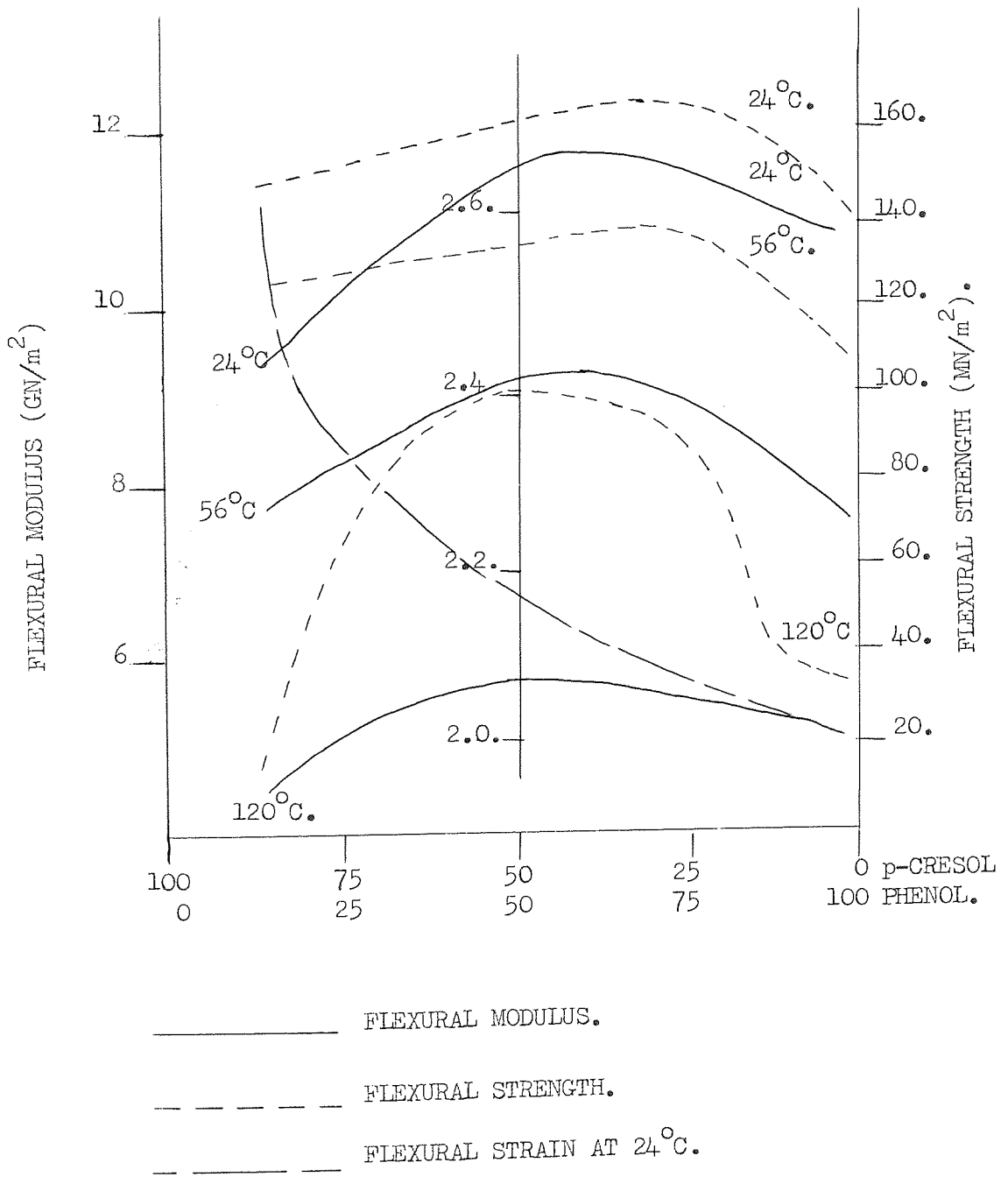

FIGURE 37. FLEXURAL PROPERTIES OF PHENOL/p-CRESOL RESINS.

methyl group is not in fact very large. Further the maxima shown can only readily be accounted for if crosslinking is the cogent factor.

Figure 38, which is a generalised picture of the flexural behaviour may be seen as divided into three separate regions, A, B and C. The variation in properties as the composition of the phenol part is varied may be explained by examining each region in detail.

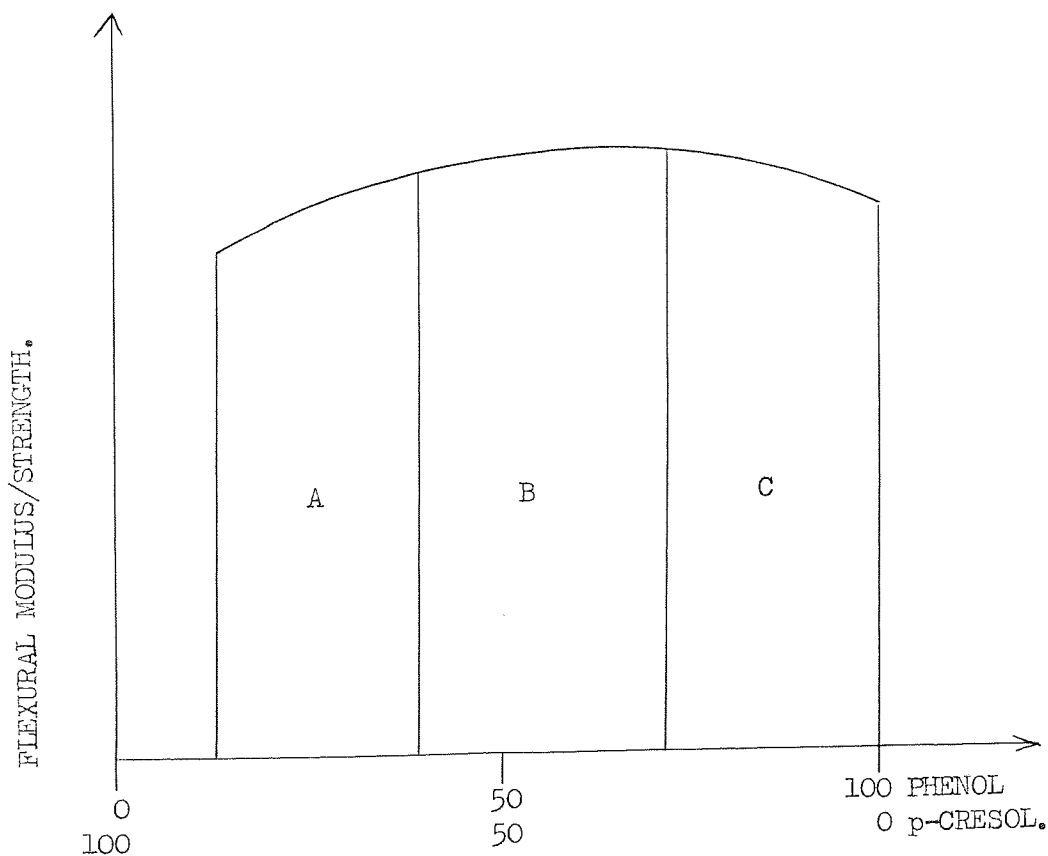

FIGURE 38. GENERALISED PICTURE OF FLEXURAL BEHAVIOUR.

REGION A.

Flexible p-cresol-methylene chains are loosely crosslinked by phenol and there is some degree of thermoplasticity. It seems quite possible that at very high p-cresol content the crosslinking potential of phenol is almost completely realised. Thus the polymer might be described as a lightly crosslinked thermoplastic.

REGION B.

The phenol-methylene structure now forms a major part of the network and the bifunctional p-cresol still confers enough pliability in the chain to give maximal crosslinking. How far this is complete is not however clear. The overall picture of the cured resin is a fairly complete phenol/methylene network containing individual inert p-cresol groups. It is considered that the structure is sufficiently open and the proportion of phenol capable of crosslinking high enough to confer extremely rigid properties to the cured resin.

REGION C.

The phenol-methylene structure now dominates and it seems possible that crosslinking may be limited by this fact. Thus a major proportion of the methylene groups are prevented from reacting by being unfavourably placed in the network.

This appears to be in accordance with Houwink's "Lockerstellen" concept. Thus as the macromolecule grows in size approach by phenol alcohols becomes increasingly sterically hindered. Hence new centres must be formed to accommodate the growth of further areas of highly crosslinked nuclei. The picture envisaged then is one of regions containing highly crosslinked nuclei surrounded by low molecular weight material. These surrounding regions provide an explanation of

Houwink's "flaws" and thus of the low technical strength of high phenol content resins.

5. 4. 3. DYNAMIC MECHANICAL PROPERTIES.

The dynamic test results (See Figure 39) are interesting within their limits of significance, in that they show dramatically the inter-dependence of resin composition and thermomechanical behaviour. There are some limitations on the results due to lack of flexibility and definition in the method used. Clearly they must be recognised as semi-quantitative at best. In each case it is evident that the stiffness and pliability (i.e. modulus and loss factor) are not much dependent on the content of cresol (bifunctional) relative to phenol (trifunctional) up to a temperature of about 90°C. Above that, the loss increases very rapidly and modulus decreases accordingly, but only when the phenol content is under 40%. This is, of course, a direct correlation with technological experience where the traditional composition of an electrical laminate contained a resin made from about 60% p-cresol and 40% m-cresol. Such materials are only barely punchable at around 120°C unless some sort of plasticiser is added. This behaviour was also indicated in some results of Watson (loc cit) and the present results confirm this finding.

It is thought that there is a fairly strong overall presumption that the differences between the several resins used are due to variation in the number of crosslinks actually achieved. This is on the assumption that there would not be much difference in stiffness of chains made from phenol itself and blends with p-cresol. It might be thought that there is a limiting value between one crosslink per two aromatic nuclei and one per two and one half nuclei. In

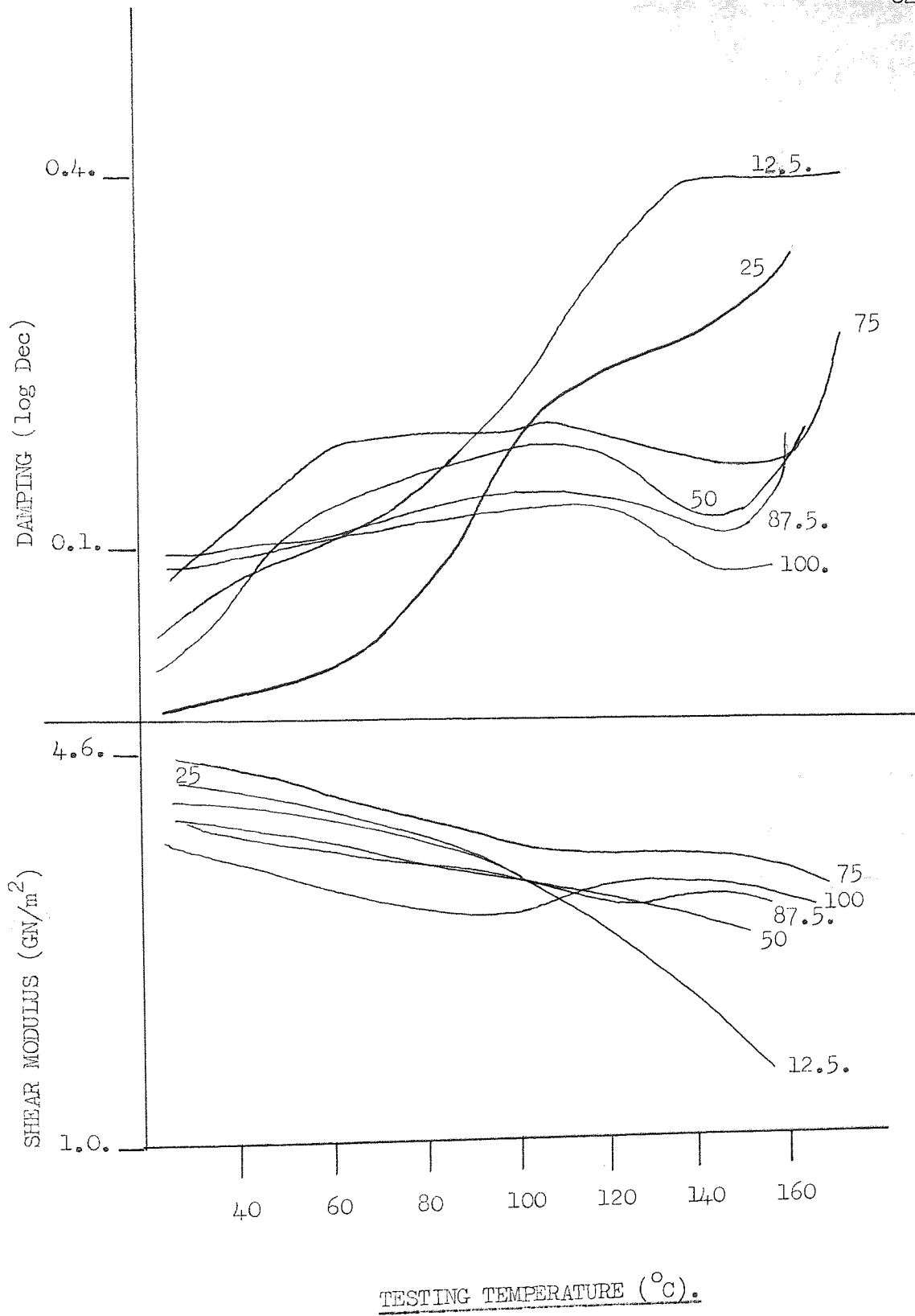

FIGURE 39. DYNAMIC MECHANICAL PROPERTIES OF PHENOL/p-CRESOL RESINS.

Values on graph refer to phenol content(%).

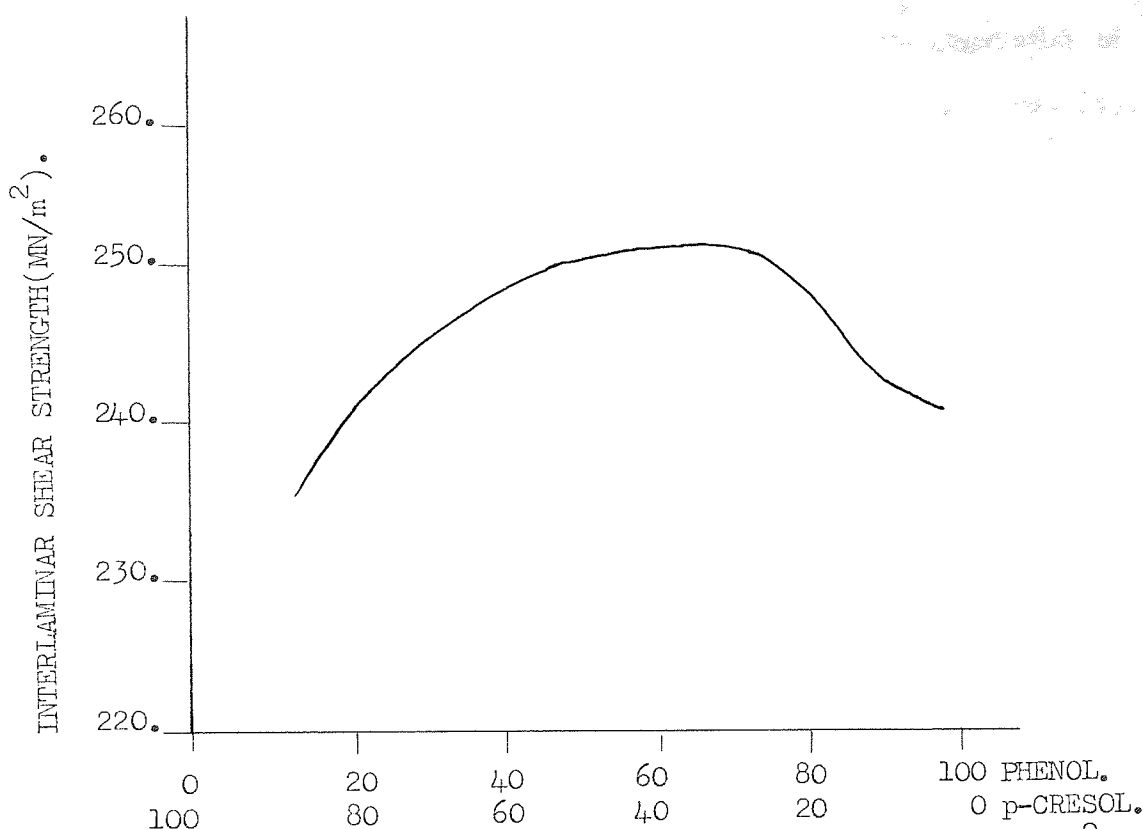

FIGURE 40. INTERLAMINAR SHEAR STRENGTHS, PHENOL/p-CRESOL RESINS (24°C).

other words, when the ratio of cresol is somewhere between 60 and 50% of the total phenols present, there is a network of optimum structural stiffness at elevated temperature. Above these values there is an appreciable degree of thermoplasticity present. This may be what is desired for a "punching grade" laminate but other properties like toughness and temperature resistance may be unfavourable.

Though in some respects these results are consistent with the postulates of Megson and Pritchett, it is difficult to agree that chain entanglement alone is the main cause of stiffness in technological plastics based on resins such as have been described, except at very low phenol content.

It is suggested that the temperature dependence of flexural properties is a consequence of increased segmental motion about methylene bridges rather than of decreased main chain entanglement. Further, if it is accepted that intramolecular hydrogen bonding between adjacent phenolic hydroxyl groups contributes substantially to

molecular rigidity then, as temperature increases, the magnitude of these secondary forces will decrease. Therefore, molecular flexibility will be further enhanced.

5. 4. 4. INTERLAMINAR SHEAR PROPERTIES.

Interlaminar shear results illustrated in Figure 40 display trends similar to those given by the flexural test data. Shear strength again approaches a maximum value between 60 and 80% phenol content which provides a close comparison with the flexural strength data at this temperature (24°C).

Figures 41 and 42 illustrate the variation of punching quality (P.Q.) with punching temperature and resin composition. The following general trends are apparent from these results:-

1. P.Q. increases with punching temperature.
2. P.Q. increases with cresol content.
3. The temperature dependence of P.Q. becomes less marked as cresol content increases.

Point 1 merely confirms the experience of previous workers⁽¹⁾. Thus as temperature increases the resin becomes less brittle due to a general increase in segmental motion and a reduction in the magnitude of secondary forces present. Points 2 and 3 suggest that as the cresol content increases the laminate assumes a higher degree of thermo-plasticity. Thus as the resin loses its inherent brittleness, the materials exhibit a greater tendency to punch "cleanly". Consequently visual defects are reduced to a minimum and P.Q. increases to a satisfactory level.

It is interesting to note here that materials possessing high damping and flexural strain to break values (See Sections 5.4.2-3)

tend to possess satisfactory punching characteristics. Further comparison with the results presented in those sections suggest that an increase in P.Q. is accompanied by a reduction in shear modulus (G) values.

5. 4. 5. PUNCHING PROPERTIES.

Table 8 summarises the punching properties of the phenol-p-cresol resins over the temperature range investigated.

5. 5. CONCLUSIONS.

The previous section provides a summary of the punching behaviour of a series of phenol-p-cresol resins. The manner in which resin composition may control mechanical (particularly punching) properties has a great technological significance in the laminating industry and therefore warrants detailed attention. The general question of structural influences regarding various resins will be argued in greater depth in Chapter 9.

At this juncture it is considered advisable to bear in mind the following points which have emerged from this investigation:-

1. The phenol-p-cresol system has presented a simple model for examining the general question of "crosslinking" and its effects on resin properties.
2. The number of potential crosslinking sites present appears to have a significant effect on mechanical properties.
3. In addition to punching other mechanical properties have been assessed in this section. These have provided a deeper understanding of the problem in a controlled and detailed fashion.
4. Generally punching trends are similar to those exhibited by the mechanical properties.

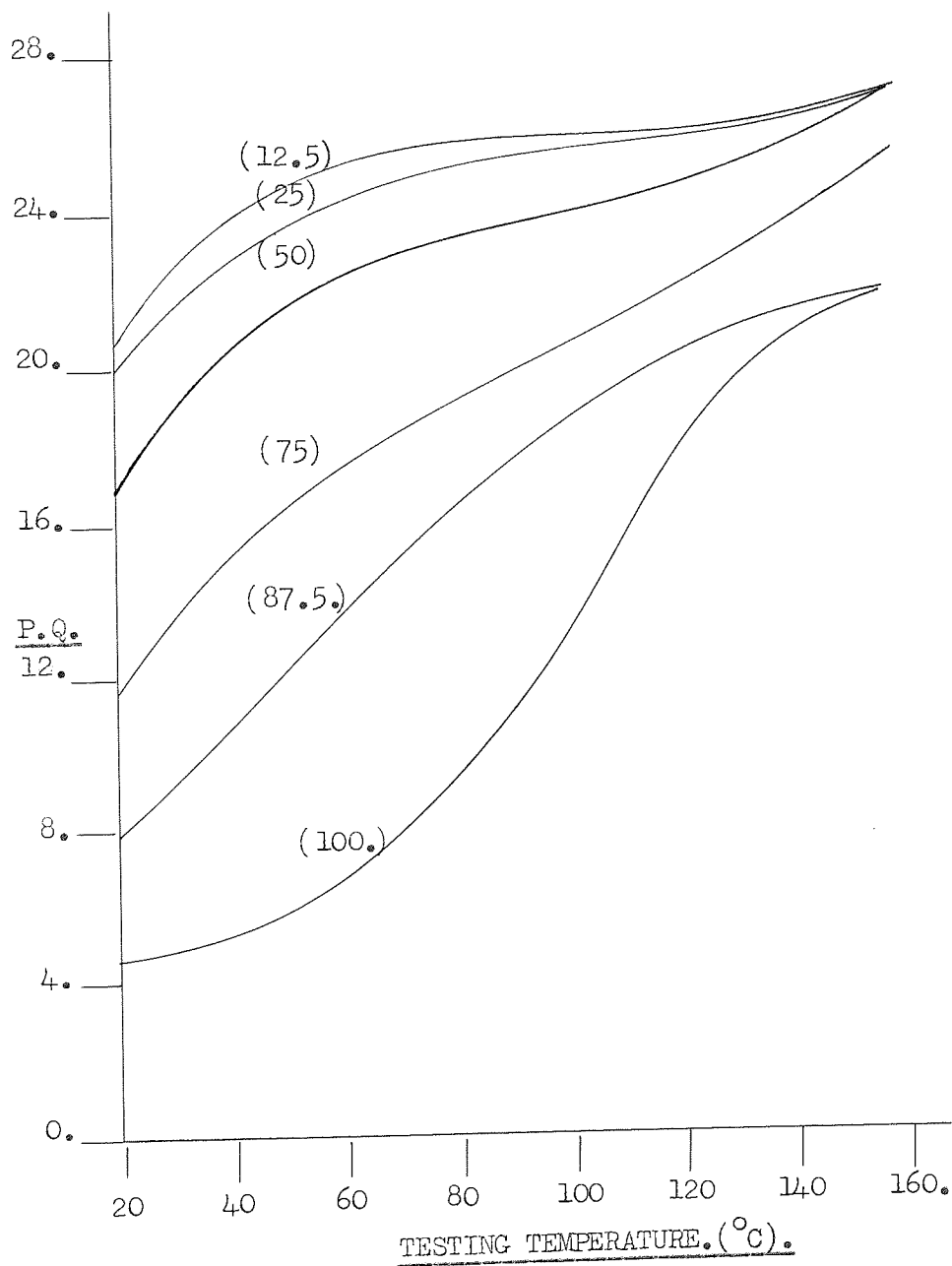

FIGURE 41. P.Q. AS A FUNCTION OF TEMPERATURE (PHENOL/p-CRESOL RESINS.).

FIGURES IN PARENTHESES REFER TO PHENOL CONTENT(%).

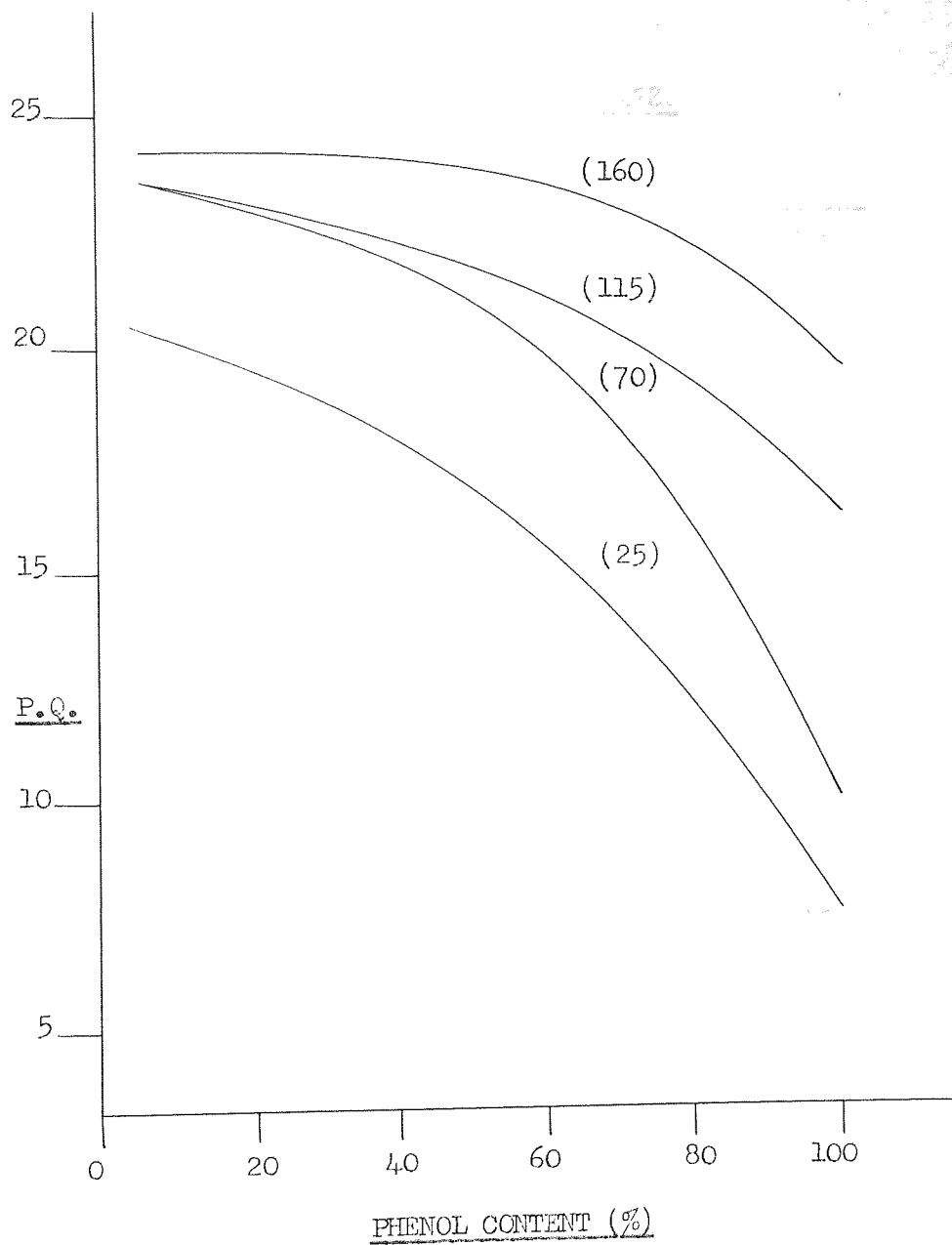

FIGURE 42. P.Q. AS A FUNCTION OF RESIN COMPOSITION (PHENOL/p-CRESOL RESINS).

FIGURES IN PARENTHESES REFER TO TESTING TEMPERATURE. (%)

TABLE 8. PUNCHING PROPERTIES OF PHENOL-~~10~~CRESOL RESINS.

| RESIN % PHENOL. | TEMPERATURE °C. | P.Q. | VISUAL DEFECTS * | CONCLUSIONS |
|-----------------------|--------------------|------|------------------|-------------|
| 100. | 25. | 5. | F.H.E.T. | |
| | 70. | 8. | H.T. | Bad. |
| | 115. | 16. | H.T. | Poor. |
| | 160. | 20. | H. | Good. |
| 87.5. | 25. | 9. | F.H.E.T. | Bad. |
| | 70. | 15. | H.E.T. | Poor. |
| | 115. | 18. | H.T. | Good. |
| | 160. | 20. | H.E. | Good. |
| 75. | 25. | 12. | F.H.T. | Bad. |
| | 70. | 17. | F.H. | Poor. |
| | 115. | 20. | H. | Good. |
| | 160. | 23. | H. | Excellent. |
| 50. | 25. | 16. | F.H.E.T. | Poor. |
| | 70. | 21. | F.H.E. | Good. |
| | 115. | 22. | H.E. | Good. |
| | 160. | 25. | H. | Excellent. |
| 25. | 25. | 19. | F.H.T. | Good. |
| | 70. | 22. | H. | Good. |
| | 115. | 24. | H. | Excellent. |
| | 160. | 25. | H. | Excellent. |
| 12.5. | 25. | 20. | H.F. | Good. |
| | 70. | 24. | H. | Excellent. |
| | 115. | 25. | H. | Excellent. |
| | 160. | 25. | H. | Excellent. |

* E = Cracks to edge.
 F = Feathering.
 H = Haloing.
 T = Tensile cracking.

CHAPTER 6.

RESINS BASED ON SUBSTITUTED PARAFFINS.

6. 1. INTRODUCTION.

Molecular flexibility has been controlled by varying the number of crosslinks in the system. It was shown in Chapter 5 that these have a considerable influence on the mechanical properties of the laminate. In order to extend this section of the work it was decided to introduce elements of greater rotational freedom to the resin by the use of carefully selected monomers.

Bearing in mind Doroshenko's⁽⁶²⁾ work, it was thought pertinent to synthesise monomers based on substituted paraffins.

A synthesis of 1:3-di(o-hydroxy phenyl)propane has been described by Carpenter and Hunter⁽⁶⁶⁾. Referring to Figure 43, it can be seen that the internuclear aromatic distance is fairly short in the conventional phenol/formaldehyde resin.

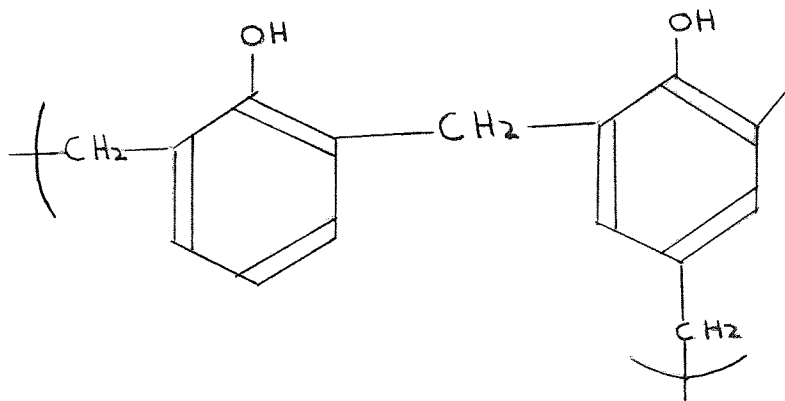

FIGURE 43. ELEMENT OF CURED PHENOL/FORMALDEHYDE RESIN.

This encourages close approach of the phenolic hydroxyl groups and hence hydrogen bonding within the resin, which is partly responsible

for main chain stiffness. If a resin based on 1,3-di-(o-hydroxyphenyl) propane (See Figure 44) were constructed, the increased inter-nuclear aromatic distance would lend a greater degree of rotation about the methylene bridges. This would decrease the tendency for intramolecular hydrogen bonding and thus introduce centres of flexibility to the resin macromolecule.

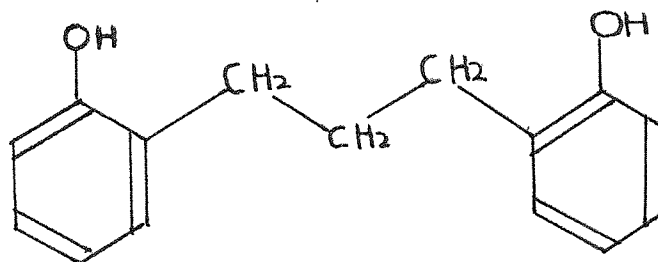

FIGURE 44. 1,3-di-(o-hydroxyphenyl)propane. ("PROPANE").

Thus laminates were manufactured based on the resins described in Table 9.

TABLE 9. "PROPANE" BASED RESIN.

| RESIN. | CONSTITUTION. | "PROPANE" PHENOL MOLAR RATIO. |
|--------|--------------------|----------------------------------|
| Q. | "PROPANE" / PHENOL | 3 : 7. |

1,3-di-(o-hydroxy phenyl)propane is prepared by a two-stage synthesis. A probable mechanism for the reaction is outlined in Figure 45.

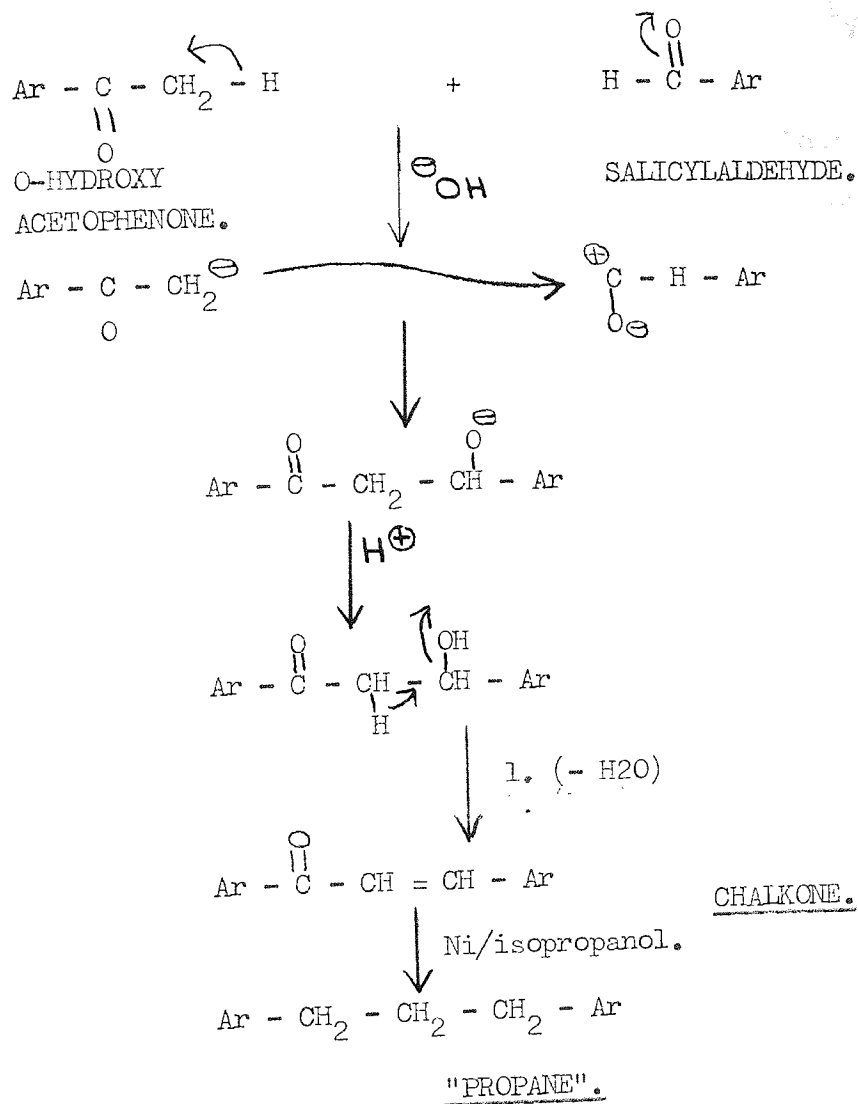

FIGURE 45. REACTION MECHANISM. (1,3-di(o-HYDROXYPHENYL) PROPANE).

STAGE I.

2,2'-di-hydroxy chalkone was prepared by the "hot condensation" method of Geissman and Clinton⁽⁷⁹⁾ from α -hydroxyacetophenone and salicylaldehyde. No experimental difficulties were encountered and the yields exceeded 85%.

STAGE II.

This involves reduction of the chalkone to give the propane derivative. This is by a non-classical reduction technique and is achieved by refluxing the chalkone with isopropanol and a Raney nickel catalyst. This method is based on the work of Kleiderer and Komfield⁽⁸⁰⁾ who describe the use of Raney nickel and various solvents in both oxidation and reduction reactions. In the present system isopropanol acts as a hydrogen donor in the presence of Raney nickel and is oxidised to acetone. This technique is quite efficient and offers many advantages experimentally to the usual high pressure hydrogenation methods.

The most difficult part of the synthesis involves preparation of the catalyst. Nickel-aluminium alloy (1:1) is treated with a solution of sodium hydroxide to separate the aluminium (as sodium aluminate). The nickel is washed by suspension in distilled water and decanted until the washings were neutral to litmus and then a further 10 times to remove the alkali completely. In practice it was found that 20-30 water washings were necessary to give an efficient catalyst. The washings were then repeated with alcohol (95%) and the product stored under alcohol (absolute) in a closed vessel.

6. 1. 1. EXPERIMENTAL.

The "propane" was prepared in three batches of 1 mole scale each. This practice enabled the experimental conditions to be handled in a more controlled fashion than one large scale preparation.

STAGE I.

o-hydroxyacetophene (1 mole), salicylaldehyde (1 mole) ethanol (350 ml) and potassium hydroxide (270 gm in 270 ml water) were mixed with stirring in a 2 l split resin flask and slowly heated to 52°C. The flask was then sealed and maintained at 52°C for 18 hours in a hot air oven.

On cooling the reaction mixture was acidified against congo red with hydrochloric acid (concentrated) and the precipitated solid collected by filtration.

The product when air dried and recrystallised from toluene gave 120gm of 2,2'-dihydroxy chalkone.

m.p. 162°C (literature value⁽⁶⁶⁾ = 161 - 163°C).

Yield, 50%

STAGE II.

2,2'-dihydroxychalkone (.5 mole), isopropanol (1 l) and Raney nickel (150gm) were heated under reflux for 24 hours. After cooling the nickel was removed by decantation and the solvent evaporated to give an oil which crystallised. Recrystallisation from benzene/light petroleum (1:1 by volume) gave 103gm. "propane". Recrystallisation from light petroleum furnished the pure compound as white needles.

m.p. 98 - 99°C (literature value, ⁽⁶⁶⁾ 97 - 99°C.).

Yield 90%

The resin described in Table 10 was prepared in the normal way using an overall ArOH:CH₂O molar ratio of 1:1.9. Laminates were made from these resins using the technique described in Chapter 5.

6. 2. MECHANICAL PROPERTIES OF "PROPANE" RESIN.

Flexural and dynamic mechanical properties were determined in the usual manner. The former was assessed at two temperatures only owing to the limited quantity of material available.

6. 2. 1. DISCUSSION OF RESULTS.

Referring to Table 10 it is noted that flexural properties are significantly lower than either the phenol or p-cresol resins. Similarly strain to break values are considerably higher at the temperatures tested. Dynamic mechanical test results suggest that shear modulus values are generally lower and damping higher than the phenol resins. (See Figure 46.).

TABLE 10. FLEXURAL PROPERTIES OF "PROPANE" RESIN.

| TEMPERATURE (°C) | MODULUS (GN/m ²) | STRESS (MN/m ²) | STRAIN AT BREAK (%) |
|---------------------|---------------------------------|--------------------------------|------------------------|
| 22 | 9.16. | 113. | 2.43. |
| 82. | 5.86. | 66.1. | 2.85. |

These results suggest the following points:-

1. Flexible units have been incorporated into the system.
2. The degree of rotational freedom about internuclear bonds has been increased.
3. Intramolecular hydrogen bonding has been reduced due to the increased internuclear distance.

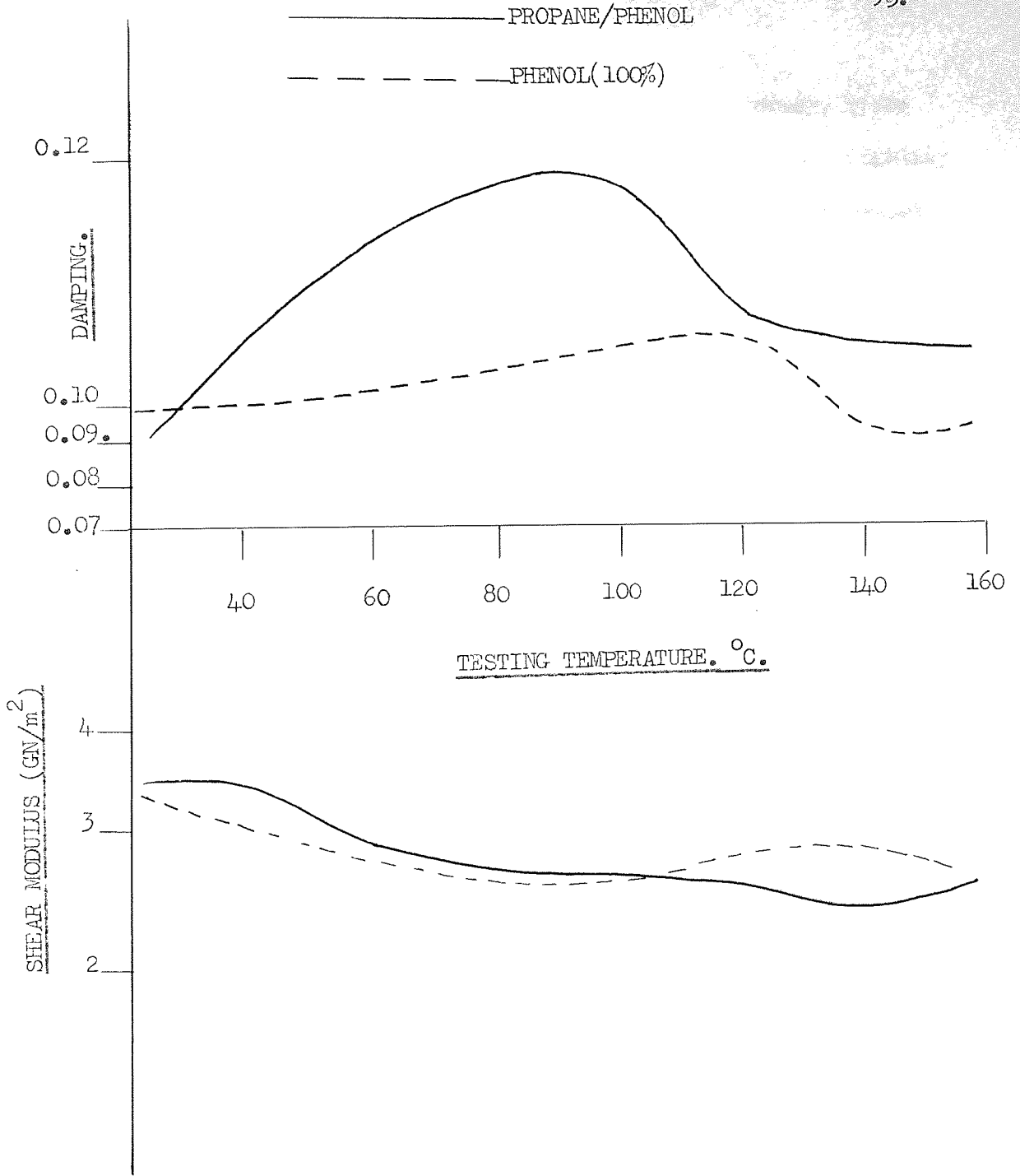
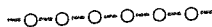

FIGURE 46. DYNAMIC MECHANICAL PROPERTIES OF "PROPANE" AND PHENOL RESINS.

It is possible that incorporation of propylene linkages leads to a more open structure. However, it is contended that the rigidity of such a system is more than compensated for here by the increased number of rotational elements and the reduction in secondary bond forces. This suggests that the latter may in fact have a considerable influence upon resin brittleness.

The insertion of methylene bridges is likely to have more influence than the additional bulk created by replacing phenol with p-cresol molecules. Consequently the damping peak at 95°C may be the result of the flexible propylene group. The material will have a limited "toughening" effect at higher temperatures compared with p-cresol since the "propane" molecule contains two active p-positions available for single methylene bridge formation. Thus even at high temperatures the laminate will possess some elastic properties.



CHAPTER 7.SUBSTITUTED PHENOLS.7. 1. INTRODUCTION.

Industrially cresols are used extensively in the manufacture of laminating varnishes. By varying the proportions of the various methyl isomers it is possible to control the properties of the resin and hence the laminated material. It would, therefore, be interesting to examine this facility in a quantitative fashion.

There are three positions in the phenol nucleus where mono-substitution may take place, namely the ortho, meta and para positions. In the ortho position it seems likely that substitution may shield the phenolic hydroxyl group and thus reduce its facility for intra-molecular hydrogen bonding. In the para-position it has already been noted that the reduced functionality of the phenolic nucleus leads to a reduction in crosslinking potential. Finally with reference to Freeman's work with m-isopropyl phenol, it was noted that bulky substituents in the meta position have a considerable influence on laminate properties.

It would appear from the literature that little work has been done in this area of the field. To extend our knowledge, therefore, on structure-property relationships the systems outlined in Table 11 were chosen to examine this area.

TABLE 11. SUBSTITUTED PHENOLS.

| RESIN. | "PHENOL" |
|--------|--------------------------|
| W | o-tertiary butyl phenol. |
| X | o-methyl phenol. |
| Y | m-methyl phenol. |
| Z | m-isopropyl phenol. |

Thus it should be possible to assess both the effects of position and bulk of substituents on the resin properties.

7. 2. EXPERIMENTAL.

7. 2. 1. o-TERTIARY BUTYL PHENOL RESIN.

This was prepared in the normal way using an ArOH/CH₂O molar ratio of 1:1.12. After 70 minutes reflux analysis of the reflux return indicated the presence of 22% formaldehyde. This figure had only fallen to 18.2% after 130 minutes reaction time. A small strip of bleached Kraft paper was impregnated with the resin to 45% resin content value. Table 12 summarises the results of the drying time experiment.

TABLE 12. DRYING TIME EXPERIMENT.

| TIME. (Min.). | TEMPERATURE. (°C.). | PROPERTIES OF 4 PLY LAMINATE. |
|------------------|------------------------|---|
| 45. | 100. | Extensive flash, delaminated on cooling |
| 60. | " | Delaminated readily by hand pressure. |
| 80. | " | " " " " " |
| 125. | " | " " " " " |

A small sample of the resin was stoved at 150°C. for 20 minutes. On cooling to room temperature the liquid resin solidified. Reheating above 100°C melted this solid. This procedure was repeated several times with identical results.

Thus it seems that the resin possesses a thermoplastic nature

rendering it incapable of crosslinking. This will be discussed in greater detail in Section 7.4.

In an attempt to overcome these difficulties it was decided to incorporate a pure phenol resin in this system as a crosslinking agent. The proportions of the two phenols used in this formulation were:-

Phenol|o-tertiary butyl phenol = 1:3 (molar).

The mixed resin was prepared in the normal way and manufacture of a laminate again attempted. However, this procedure still gave rise to an unsatisfactory material in which delamination was again extensive. Stoving of the resin at 150°C indicated that the resin still possessed a considerable degree of thermoplastic character.

In view of these difficulties, work on the o-tertiary butyl resin was discontinued.

7. 2. 2. o-METHYL PHENOL RESIN.

This was prepared in the normal fashion and mixed with a phenol formaldehyde resin. The proportion of o-methyl phenol|phenol was 3:1 (molar) and the overall scale used was 7 molar.

The o-methyl phenol resin alone cured after stoving at 150°C for 20 minutes and a satisfactory laminate could be made from the mixed resin.

7. 2. 3. m-METHYL RESIN.

This was prepared by the procedure outlined above using an ArOH|CH₂O molar ratio of 1:1.45. Examination of the m-methyl phenol resin and the mixed resins gave similar results to those obtained in Section 7. 2. 2.

7. 2. 4. m/p-ISOPROPYL PHENOL.

The pure starting material was not available at a reasonable price

for the scale of work. However, a mixed meta, para isopropyl phenol containing 65% of the meta isomer was cheaply available and this was used as a compromise.

Initially it was hoped that the pure meta isomer might be separated by a chromatographic method. This was attempted on a Pye gas liquid chromatograph, using a variety of columns. (See Table 13.). However, in no case was separation achieved.

TABLE 13. SUMMARY OF GLC VARIABLES.

| COLUMN LENGTH. (ft). | COLUMN PHASE. | TEMP: RANGE. (°C). | SAMPLE VOLUME. (/ul). |
|-------------------------|---------------|-----------------------|--------------------------|
| 5.(1.524 m.). | S.E.30. | 120 - 150. | 1. |
| " | P.E.G.A. | " " | " |
| " | P.E.G. 600. | " " | " |
| " | APIEZON. | " " | " |
| 15.(4.572 m.). | S.E.30. | " " | " |

A resin was, therefore, prepared from the mixed isomers. Experimental conditions were as above and an $\text{ArOH}|\text{CH}_2\text{O}$ molar ratio of 1:1.36 was used. The resin (alone and mixed with phenol resin) had properties similar to the methyl phenols.

7. 3. PROPERTIES OF SUBSTITUTED PHENOLIC RESINS.

Bleached Kraft paper was impregnated with the resins, X, Y and Z respectively and laminated at 150°C/1000 p.s.i. (6.9 MN/m²) in the usual way.

The resins were tested under flexural and static shear loading in the normal fashion. Punching and dynamic mechanical properties were determined in the manner previously described in Chapter 4.

7. 4. DISCUSSION OF RESULTS.

Figures 47, 48, 49, 50 and 51 illustrate the expected dependence of modulus and strength on temperature. In addition they demonstrate quite clearly the marked difference in mechanical properties of the three substituted resins investigated. Perhaps the most remarkable facet of these results is the close similarity in properties of the difunctional o-methyl phenol and the trifunctional m-methyl phenol. The observed properties will now be treated separately in greater detail. In addition a comparison with phenol and p-cresol/phenol (3:1 molar ratio) will be noted.

7. 4. 1. FLEXURAL PROPERTIES.

Modulus and strength values are lower than the phenol and p-cresol/phenol resins, although the iso-propyl phenol modulus is marginally higher at lower temperatures.

The o-methyl phenol results may be simply explained on the basis that the molecule is difunctional and therefore incapable of forming a fully crosslinked network.

It has been mentioned earlier that intra-molecular hydrogen bonding may contribute to the rigidity of the cured phenoplast. It seems quite likely that the ortho methyl group "screens" the phenolic hydroxyl group, thus inhibiting to some extent its hydrogen bonding potential. This steric effect is absent in both the p-cresol and phenol molecules and therefore secondary forces are more likely to exist in these resins. Further the ortho-ortho linkages in p-cresol

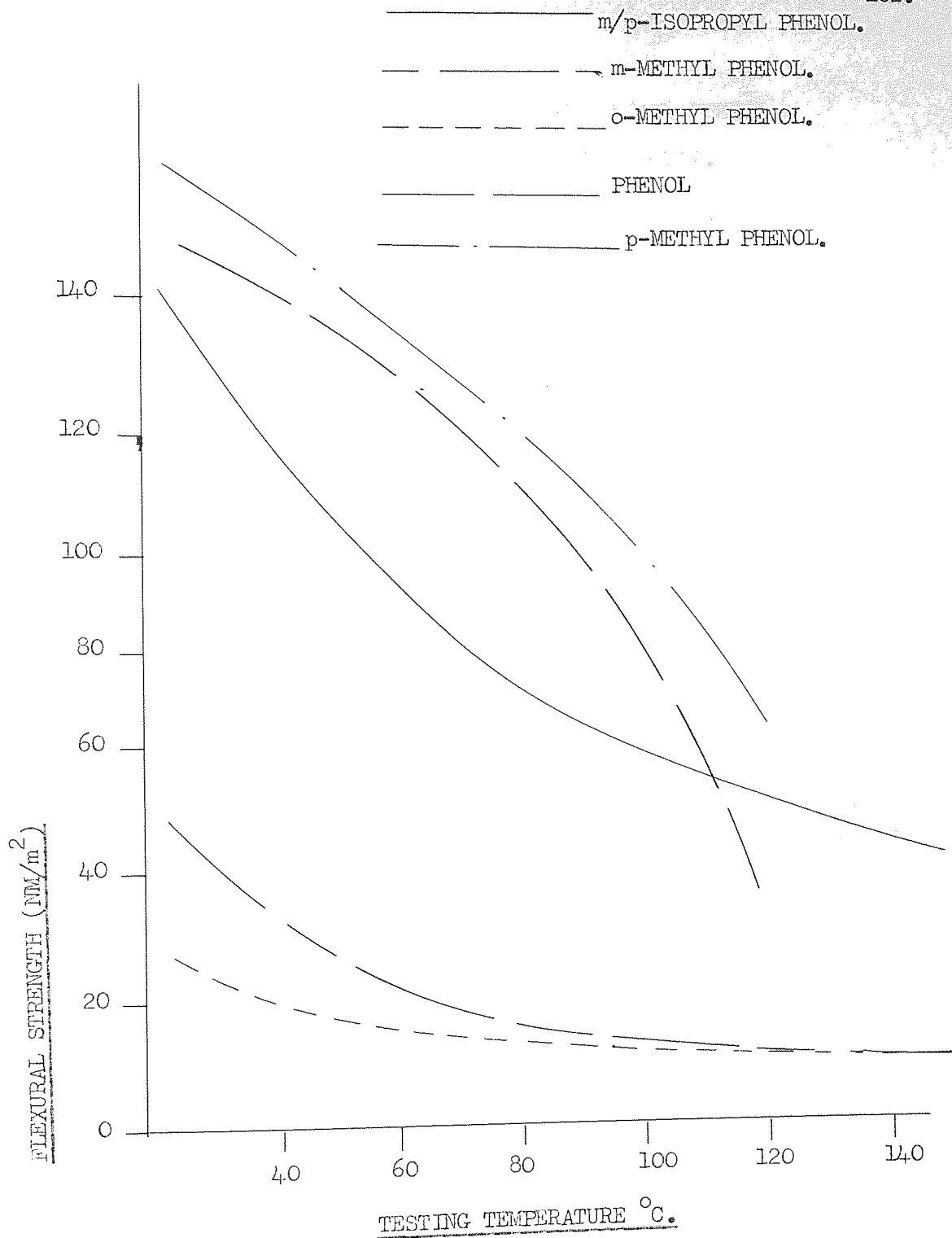

FIGURE 47. FLEXURAL STRENGTH AS A FUNCTION OF TEMPERATURE.
(SUBSTITUTED PHENOLS).

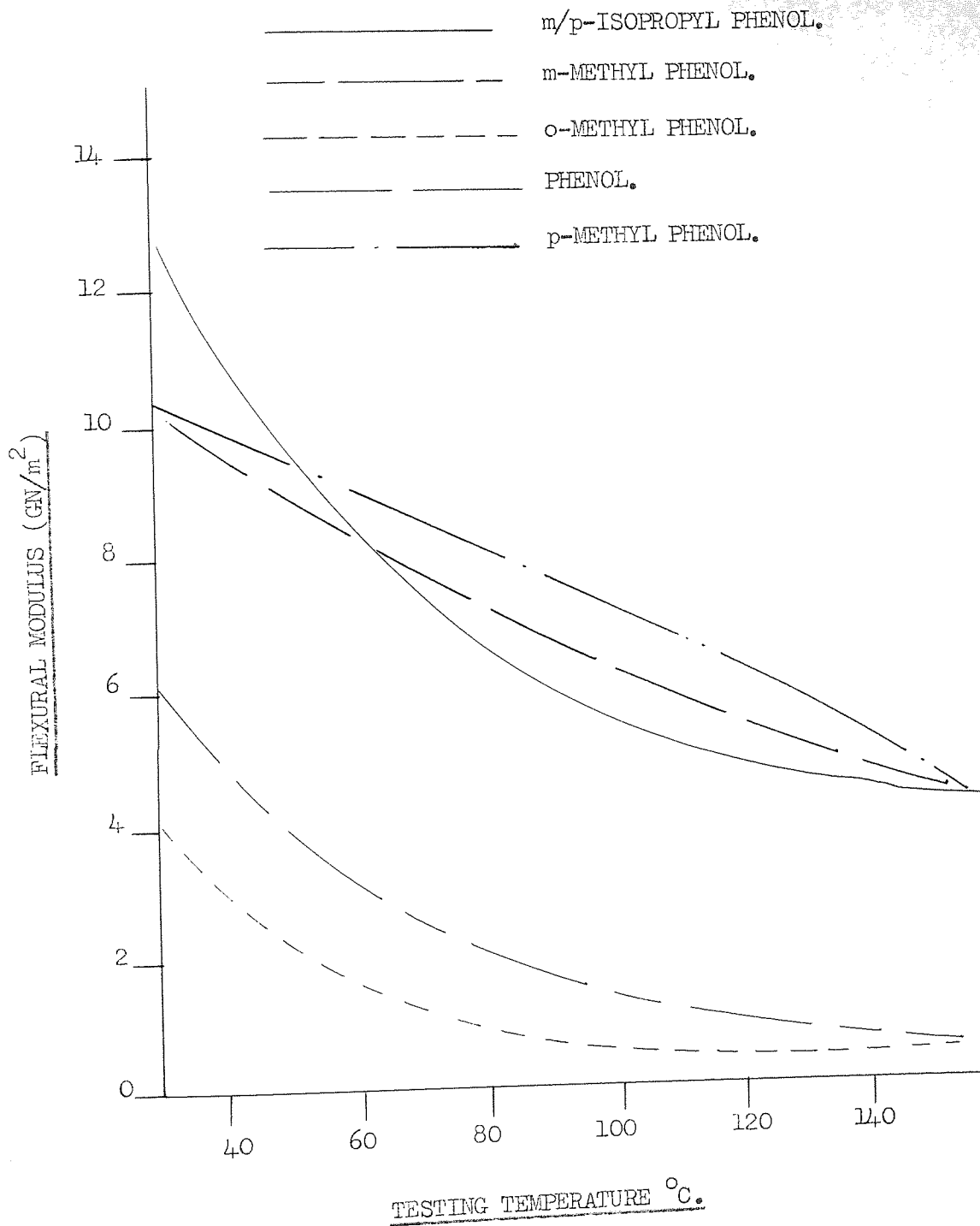

FIGURE 48. FLEXURAL MODULUS AS A FUNCTION OF TEMPERATURE
(SUBSTITUTED PHENOLS)

_____ m/p-ISOPROPYL PHENOL.
 _____ m-METHYL PHENOL.
 - - - - - o-METHYL PHENOL.
 _____ PHENOL.
 - - - - - p-METHYL PHENOL.

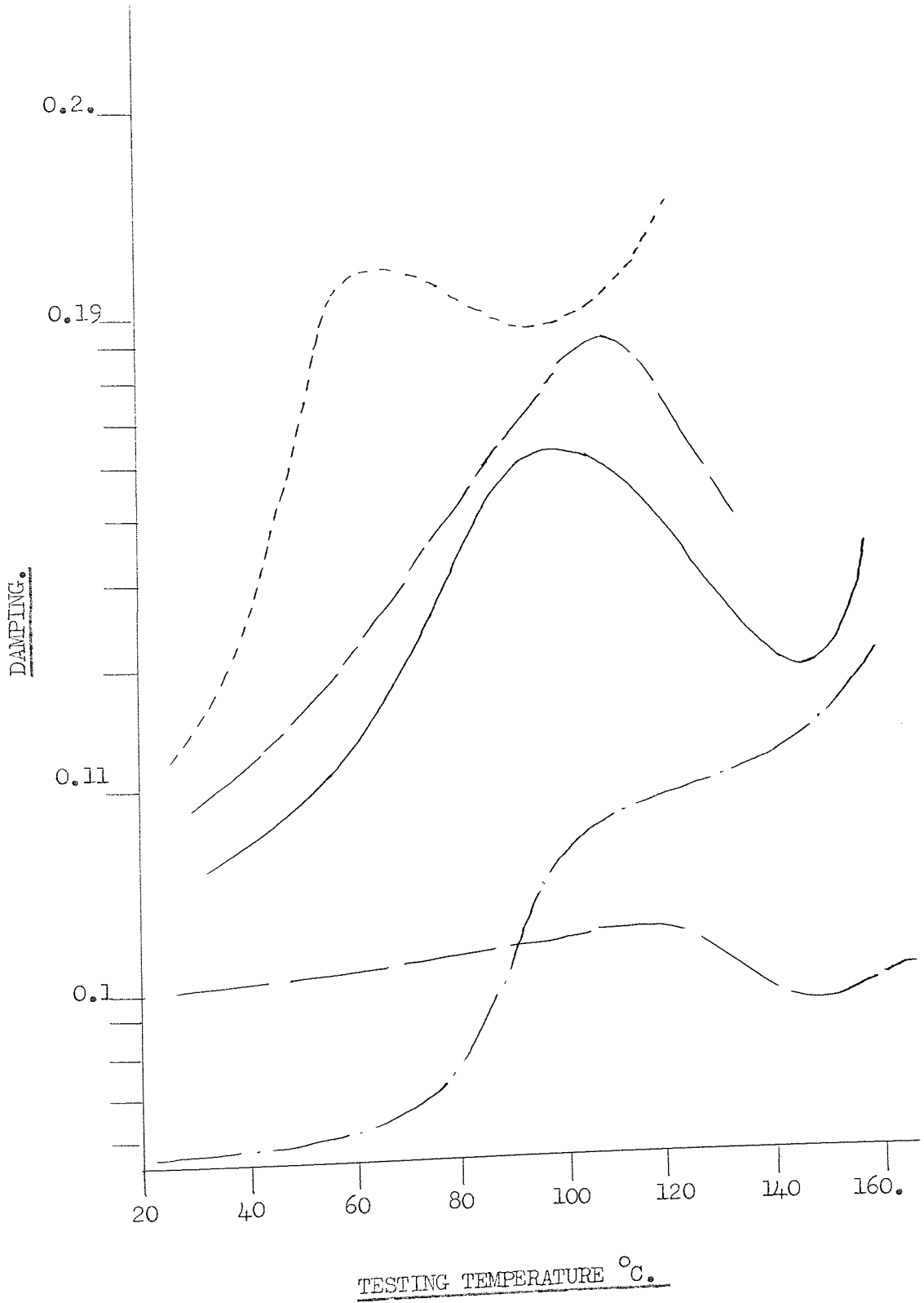

FIGURE 49. MECHANICAL DAMPING AS A FUNCTION OF TEMPERATURE.
 (SUBSTITUTED PHENOLS).

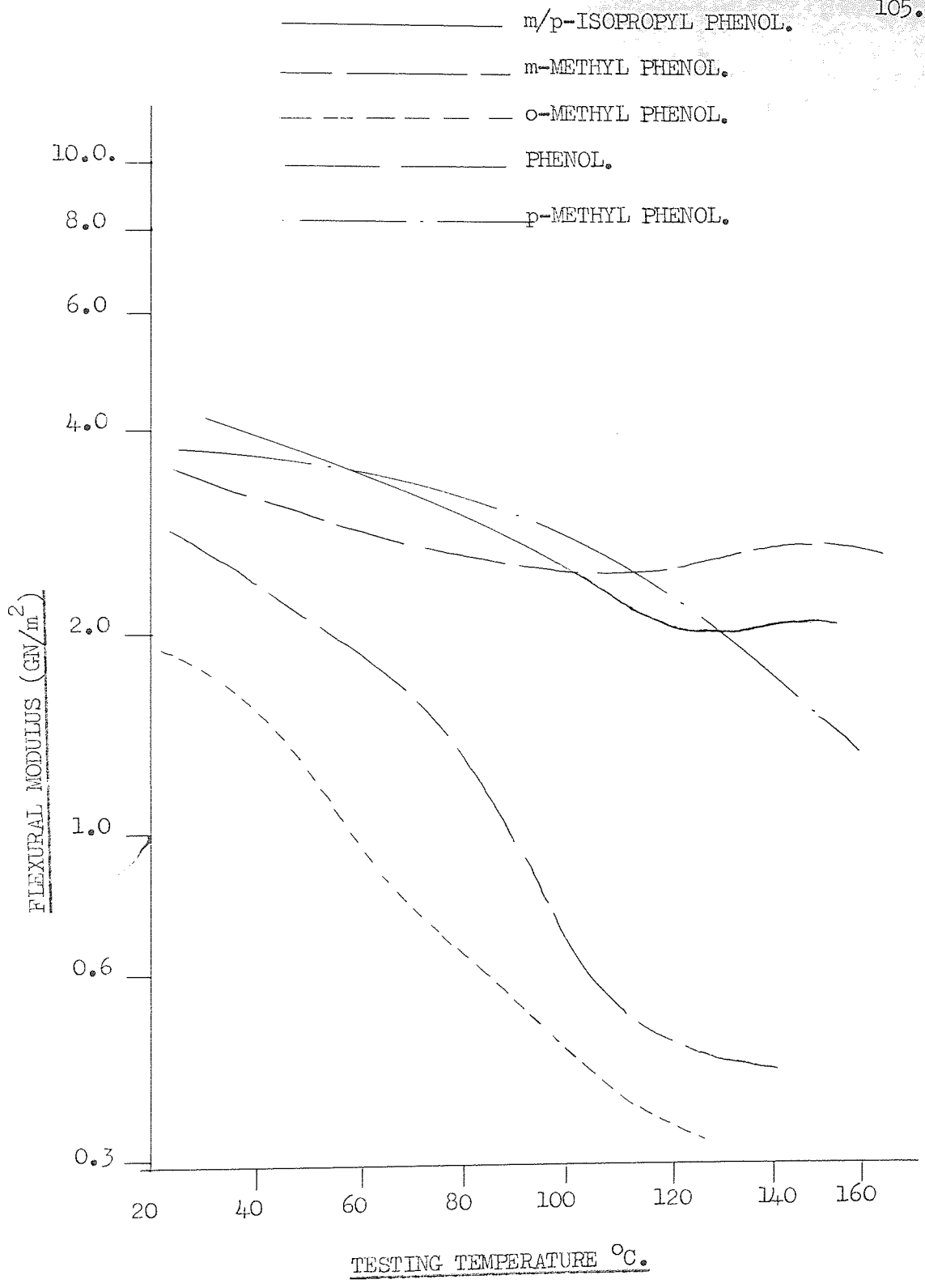

FIGURE 50. DYNAMIC SHEAR MODULUS AS A FUNCTION OF TEMPERATURE.
(SUBSTITUTED PHENOLS).

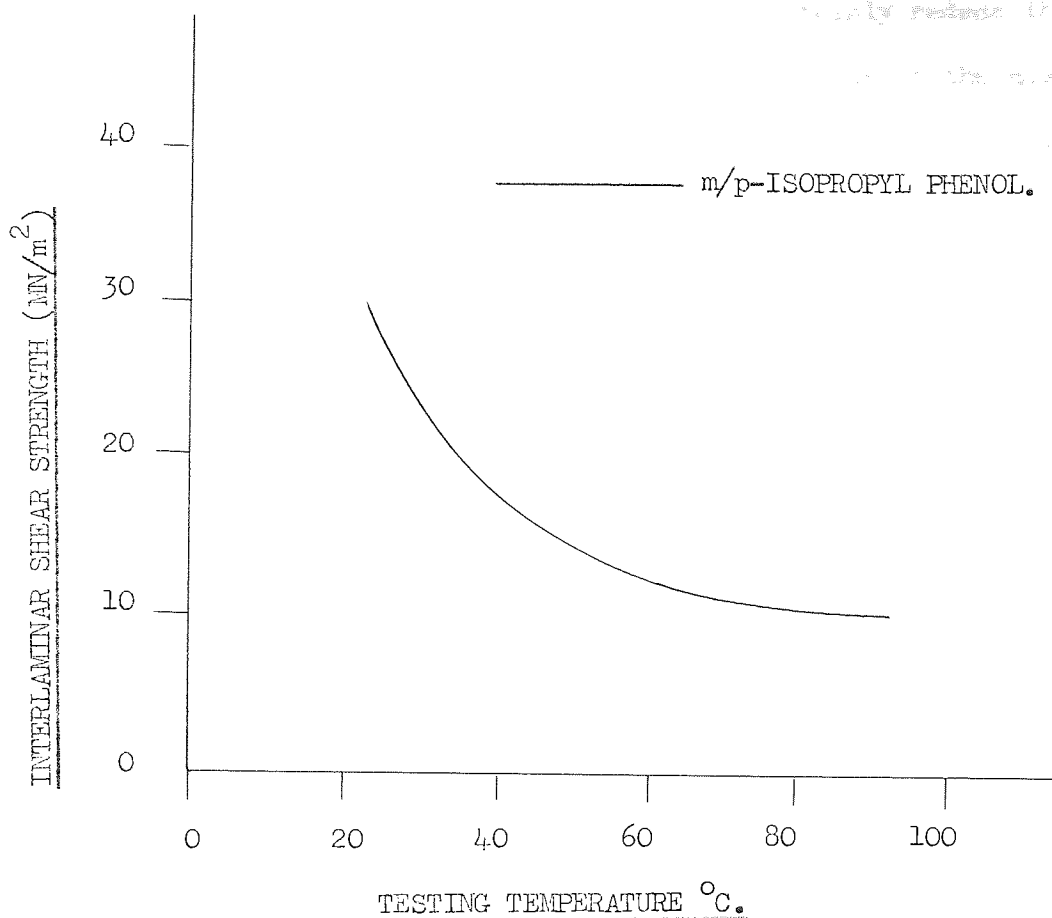

FIGURE 51. INTERLAMINAR SHEAR STRENGTH AS A FUNCTION OF TEMPERATURE

will encourage secondary forces to a greater degree than the predominantly ortho-para linkages encountered in o-methyl phenol.

m-methyl phenol, although stronger than o-methyl phenol, is weaker than the other resins. Initially this seemed surprising, since the molecule is trifunctional electronically. It is possible that the m-methyl substituent sterically hinders the adjacent ortho and para positions to a sufficient degree to discourage approach by other active molecules during the curing process. In addition it is possible that neighbouring group participation by the methyl group encourages closer approach of the ortho-hydroxy methyl group to the phenolic hydroxyl group, thus enhancing intramolecular hydrogen bonding between the Cl

and C2 substituents. These two factors would certainly reduce the number of crosslinks and thus the strength and modulus of the system. These views are rather speculative, however, and may not fully explain the anomalous behaviour exhibited by the resin.

Iso-propyl phenol should behave in a similar fashion if these views are correct. However, the picture is further complicated by the fact that the resin contained a substantial proportion of the para-isomer. The constitution of the iso propyl resin was as follows. (Percentage figures represent the molar fraction of each constituent):-

- | | | |
|------------------------|---|--------|
| 1. m-isopropyl phenol. | - | 48.75% |
| 2. p-isopropyl phenol. | - | 26.25% |
| 3. Phenol. | - | 25%. |

There are, therefore, three competing factors here. It is envisaged that constituents 2 and 3 imitate a system analogous to the p-cresol/phenol (3:1) resin. This it will be remembered has a greater rigidity than phenol alone. By comparison with meta methyl phenol, the bulky meta iso-propyl substituent is likely to hinder crosslinking via the adjacent ortho and para positions. Therefore, the initially rigid structure due to the para substituent appears to have been "diluted" in strength by the meta isomer rendering it weaker than the phenol and p-cresol/phenol (3:1) resins. Clearly it is most unfortunate that the pure meta isomer was not readily available for this programme.

7. 4. 2. DYNAMIC MECHANICAL PROPERTIES.

Dynamic shear modulus and mechanical damping as a function of temperature are illustrated in Figure 46. The trends here are similar to those exhibited by the flexural data. Thus shear modulus

values are in the order:-

p-cresol/phenol(3:1) > phenol > isopropyl phenol > m-methyl phenol > p-methyl phenol.

The corresponding damping values are in the order:-

o-methyl phenol > m-methyl phenol > isopropyl phenol > phenol > p-cresol/phenol (3:1).

These results may be interpreted on a similar basis to the flexural data. Namely, shear modulus increases and mechanical damping decreases as the number of crosslinks increases.

It is generally accepted⁽²¹⁾ that transition temperature increases with side group bulk. It might be expected then that the isopropyl transition temperature should be higher than the m-methyl transition. However, again the para isomer is influencing the resin properties and thus this "shift" has been compensated for. Comparison of the substituted resins (X.Y.Z.) with p-cresol/phenol (3:1) and phenol alone leads to similar conclusions as outlined in the previous section.

7. 4. 3. SHORT BEAM SHEAR TESTING.

Table 14 compares the interlaminar shear strengths of the resins under discussion in this chapter.

At room temperature the trends are similar to those observed above. In order to produce a family of curves similar to those obtained from flexural testing, the tests were conducted at 23°C, 50°C and 90°C. However, this was only fully possible with isopropyl phenol as illustrated in Figure 51. m-methyl phenol and o-methyl phenol did not exhibit shear failure at these higher temperatures (90°C and 50°C, 90°C respectively.).

Failure in both cases at these temperatures occurred at values in

excess of $30. \text{MN/m}^2$. Examination of the failed specimens demonstrated "crushing" at the point of failure suggesting a compressive mode of failure. Presumably the limited number of crosslinks present in these resins prevented this speed of loading initiating shear failure at higher temperatures where the resin exhibits a high degree of thermoplasticity. It is noted that the temperature at which the shear test apparently failed corresponds to the mechanical damping maxima of the two resins respectively. This supports the idea of thermoplasticity at these temperatures.

TABLE 14. INTERLAMINAR SHEAR STRENGTH (γ) OF SOME PHENOLIC RESINS.

| RESIN. | TEMPERATURE. ($^{\circ}\text{C}$) | (MN/m^2) |
|----------------------|--|---------------------|
| p-methyl phenol. | 23. | 24.3. |
| phenol. | 23. | 24.1. |
| isopropyl phenol. | 23. | 30.4. |
| | 50. | 14.4. |
| | 90. | 10.3. |
| m-methyl phenol. | 23. | 26.0. |
| | 50. | 11.4. |
| o-methyl phenol. | 23. | 0.70. |

7. 4. 4. PUNCHING PROPERTIES.

Punching properties are summarised in Table 15. The punching data for phenol ($P/f = 1/1.45$) is included so that a direct comparison may be made.

TABLE 15. PUNCHING PROPERTIES OF SUBSTITUTED RESINS.

| RESIN. | TEMPERATURE. (°C). | P.Q. | VISUAL DEFECTS. |
|----------------------|-----------------------|------|-----------------|
| Phenol. | 25. | 5. | E.F.H.T. |
| | 70. | 8. | H.T. |
| o-methyl phenol. | 25. | 4. | H.F.T. |
| | 70. | 15. | H.F. |
| m-methyl phenol. | 25. | 5. | E.F.H.T. |
| | 70. | 14. | E.F.H.T. |
| m-iso-propyl phenol. | 25. | 8. | E.F.H.T. |
| | 70. | 20. | H. |

Referring to Table 15 it is clear that at room temperature differences in punching properties are minimal. However, at 70°C phenol displays inferior properties to the three substituted phenols tested. The notable resin here is the iso-propyl phenol at 70°C. This result is in accordance with Freeman⁽⁴⁷⁾. It is noted that the substituted resins have higher damping values than phenol alone and, as illustrated in Chapter 5, punching properties are subsequently superior.

CHAPTER 8.RESIN - PAPER INTERACTIONS.8. 1. DISCUSSION.

It was noted in Chapter 3 that the paper filler consists mainly of pure cellulose. If the chemical structure of cellulose is examined it will be noted that the macro-molecule possesses a high degree of hydrophilic character. (See Figure 52.).

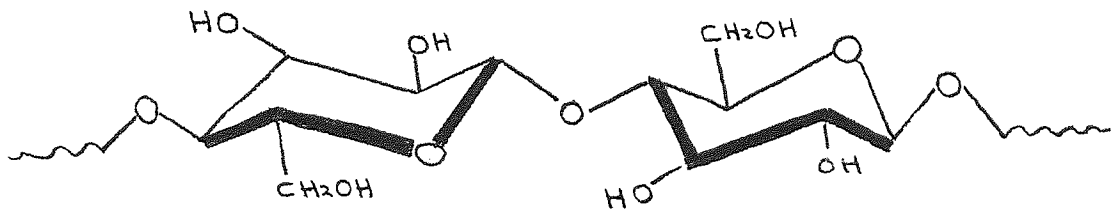

FIGURE 52. STRUCTURE OF CELLULOSE.

This then lends chemical compatibility to the hydroxyl group rich resole, thus increasing the ease with which the paper filler may be impregnated with resin.

The mechanism by which impregnation takes place may be regarded in the first instance on a physical basis.

It might be envisaged that, initially, resole molecules are accommodated within the paper matrix voids. Here, paper is acting as a resin carrier and composite strength increases with resin content. Beyond a limiting resin content, all voids are filled and further addition of resin merely enhances embrittlement of the composite.

In addition to this physical paper-resin bond it would seem likely that chemical bonding between resin and paper may provide a

further contribution to the interlaminar bond strength.

Hydrogen bonding has been attributed as the source of the high interfibre energy within the paper matrix. It is now suggested that hydrogen bonding between hydroxyl rich paper and resin may constitute a further resin-paper bond. This additional source of bonding may be responsible to some degree for the inherent brittleness of the laminate.

In order to investigate this effect it was decided to construct resins in which intermolecular hydrogen bonding potential was partially or wholly eliminated. The hydrogen bonding factor might then be assessed by comparison with unmodified resin. It was decided that these effects would be best reflected in terms of flexural properties and interlaminar shear bond strength.

It must be pointed out that chemical modification of the phenolic hydroxyl group rather than paper-base present the most viable route for this investigation. In the latter various other mechanical properties may be affected by chemical modification. Further chemical modification of hydroxymethyl groups would affect the curing mechanism of the resin. It was, therefore, decided to focus attention on the phenolic hydroxyl group. If this could be "blocked" then the resin's potential as a hydrogen bonding donor should be reduced.

8. 2. APPROACH TO THE PROBLEM.

Ideally a resin based on anisole and formaldehyde would satisfy all requirements. Unfortunately, the methyl group ether does not activate the aromatic nucleus sufficiently to induce electrophilic attack. Attention was then focused on p-cresol methyl ether in the hope that the para methyl group might activate the nucleus. Details of this investigation are described below.

8. 2. 1. EXPERIMENTAL.

p-cresyl methyl ether (0.5 mole) formaldehyde (0.72 mole 37%^W/W solution) and barium hydroxide (2 gm.) were refluxed in a small resin flask. Analysis of reflux return indicated no reaction even after 155 minutes reflux. Distillation of the reaction mixture at atmospheric pressure yield 60 gm of a liquid boiling at 173°C. (b.p. p-cresyl methyl ether, 173°C.).

It was, therefore, concluded that p-cresyl methyl ether does not react with formaldehyde under typical resin forming conditions.

Methods have been described in the literature⁽⁸¹⁾ for the methylation of phenolic resins. One such method⁽⁸²⁾ specific for the phenolic hydroxyl group was used as a basis for the investigation described below:-

Phenol (0.3 mole), formaldehyde (0.43 mole 37%^W/W solution) and sodium hydroxide (0.3 mole in 20 ml water) were mixed and allowed to stand in a stoppered flask for 48 hours. A solution of sodium hydroxide (0.3 mole in 20 ml water) and dimethyl sulphate (0.3 mole) was then added with shaking and the temperature maintained at 40°C. The solution was allowed to stand for 24 hours and then treated with 2 x 80 ml portions of ethyl acetate. The ethyl acetate extracts were combined and the solvent evaporated at 30°C/15 mm to give 60 gm of a pale yellow oil. Infra-red analysis of this oil indicated the presence of aromatic-CCH₃ at 2820-2840 cm⁻¹ together with minor traces of dimethyl sulphate and ethyl acetate.

A variation to this method involved preparation of the resole under normal reflux conditions followed by the methylation technique described above. However, the procedure results in no increase in

yield.

Preparation of methylated resin by this route was considered impracticable on a large scale basis for the following reasons:-

1. Relatively low yields.
2. Large volume of solvent necessary in the extraction stage.

Further attempts at resin methylation were thus abandoned at this stage.

8. 3. FRIEDEL CRAFTS RESINS.

It was noted earlier that p-xylylene glycol dimethyl ether (p-X.G.D.M.E.) reacts with aromatic compounds under Friedel Crafts conditions to form resinous systems. It seemed possible to construct a resin based on the reaction of p-X.G.D.M.E. with p-cresyl methyl ether and phenol. The presence of phenol in this resin could be used as a crosslinking site by further reaction of resin with formaldehyde. Figure 53 describes this scheme more clearly.

Thus a system could be constructed which possesses the phenolic resin type structure. In addition this system would incorporate "blocked" phenolic hydroxyl groups.

Friedel Crafts resins are difficult to prepare because of the ease with which they gel⁽⁷⁴⁾. A preliminary investigation was, therefore, considered necessary to gain an inside knowledge of the system. These resins may be prepared in "bulk" or in solution. The programme was, therefore, divided into two distinct stages:-

1. Bulk chemistry.
2. Solution chemistry.

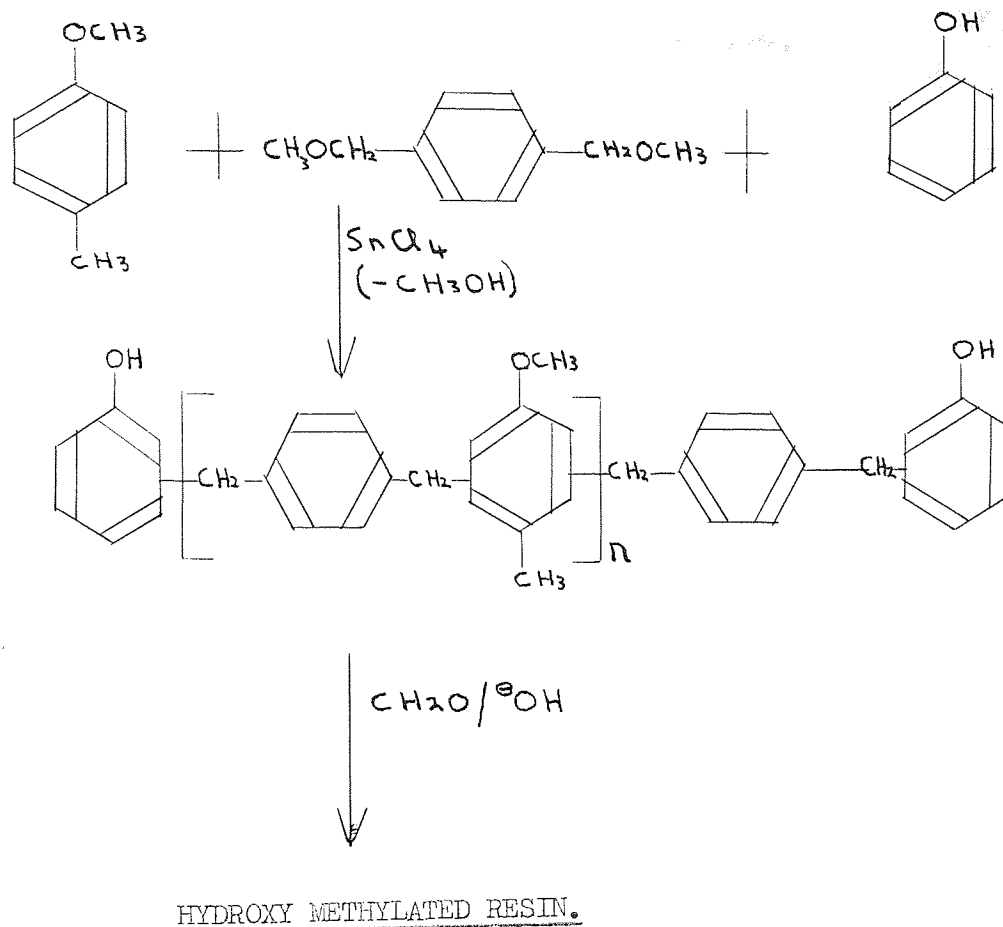

FIGURE 53. REACTION OF p-X.G.D.M.E. WITH p-CRESYL METHYL ETHER
AND PHENOL.

8. 3. 1. EXPERIMENTAL.

The apparatus used throughout this work is illustrated in Figure 54. Experimental procedure is described in Section 8.4. A summary of the systems examined is given in Table 16. This, together with experimental observations, is discussed below.

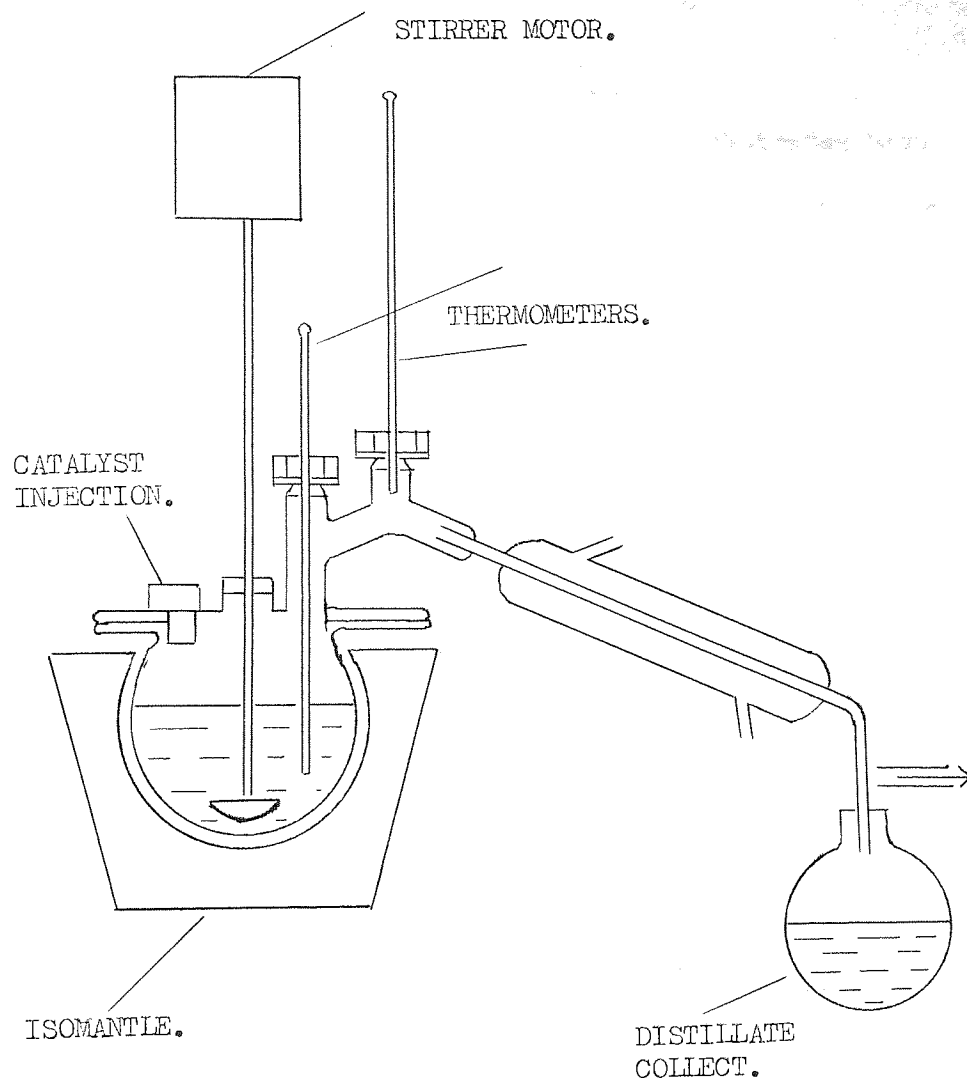

FIGURE 54. FRIEDEL CRAFTS RESIN STILL.

8. 3. 2. DISCUSSIONS OF THE PRELIMINARY PROGRAMME.

The reaction of X.G.D.M.E. with various aromatic substrates have been studied under Friedel Crafts conditions. The effects of reaction media, aromatic substrate type, temperature and extent of conversion were all examined:-

p-X.G.D.M.E. self condenses in bulk and in solution to give solid insoluble products at low conversion (measured by weight of methanol liberated). Molar ratios of ArOH|p-X.G.D.M.E. around 1:1 gave insoluble products at higher conversions. Higher molar ratios gave increased yields of soluble material and the mass remained even at 190°C. Solvent type apparently does not affect yield provided that the solvent contained electron withdrawing groups in the aromatic nucleus. Chlorinated phenol gave higher yields of less viscous material generally. A mobile oil was obtained with 2,6-xyleneol. This confirmed that p-X.G.D.M.E. does react with these types of compounds since the alternative would be self-condensation of the monomer. As reaction proceeds the reaction mixture becomes progressively darker in colour, This phenomenon is less marked in bulk than solution reactions. Possibly solvent-Sn interactions are taking place in addition to some degree of polymer oxidation.

After careful consideration of the results it was decided to use the following set of conditions in future work:-

1. ArOH| p-X.G.D.M.E. molar ratio - 1:1.2.
2. Solvent type. - Nitrobenzene.
3. Reaction temperature. - 130°C maximum.
4. Conversion limit. - 64% methanol.

It was now possible to proceed with the synthesis of the polymer illustrated in Figure 53.

TABLE 16. SUMMARY OF PRELIMINARY FRIEDEL CRAFTS RESIN PROGRAMME.

| MEDIUM | RESIN. | PHENOL DERIVATIVE. | MOLAR RATIO ArOH/ p-X.G.D.M.E. | REACTION TEMP: (°C) | OBSERVATIONS. |
|----------------------|--------|-----------------------|---|---------------------------|--------------------------------|
| BULK. | A | p-cresol. | 1:1.2. | 150-180 | Solid at 75% conversion. |
| | B | " " | 0:1. | 150-152 | Solid at 34% conversion. |
| | C | " " | 0:1. | 140-145 | Solid at 28% conversion. |
| | D | " " | 1:1.2. | 120-130 | Viscous at 64% conversion. |
| | E | " " | 0.9:1. | 120-130 | Viscous at 64% conversion. |
| | F | " " | 0:1. | 120-140 | Viscous at 64% conversion. |
| NITRO- BENZENE | G | p-cresol. | 0:1. | 135-145. | Solid at 26% conversion. |
| | H | " " | 1:1. | 120-130 | Solid at 56% conversion. |
| | I | " " | 1:1. | 124-130 | Solution at 35% conversion. |
| | J | " " | 0:1. | 119-128 | Solution at 37% conversion. |
| | K | " " | 2:1. | 128-132 | Solution at 75% conversion. |
| | L | p-chloro- phenol. | 2:1. | 124-128 | Solution at 66% conversion. |
| | M | p-cresol. | 2:1. | 130-190 | Solution at 88% conversion. |
| DICHLORO BENZENE. | N | p-cresol. | 0:1. | 152-155 | Viscous at 43% conversion. |
| | O | " " | 1:1. | 140-149 | Viscous at 53% conversion. |
| | P | " " | 2:1. | 136-143 | Viscous at 62% conversion. |
| | Q1. | " " | 2:1. | 136-145. | Viscous at 81% conversion. |
| | Q2. | " " | 2:1. | 138-145 | Viscous at 72% conversion. |
| | Q3. | " " | 2:1. | 142-146 | Viscous at 65% conversion. |
| | R | 2,6 xyleneol | 2:1. | 153-161 | Viscous at 66% conversion. |

8. 4. SYNTHESIS OF XYLOK TYPE POLYMERS.

8. 4. 1. EXPERIMENTAL.

p-cresyl methyl ether (0.075 mole), p-X.D.M.E. (0.12 mole) phenol (0.025 mole) and nitrobenzene (50 ml) were heated with stirring to 110°C. Stannic chloride (0.5 ml 20%^V/V in dichloroethane) was added with a syringe. The temperature was maintained at 130°C whilst the methanol distilled over at about 1.5 ml/min. When 6 ml methanol (corresponding to a 64% conversion) had been collected the reaction was stopped. The residue consisted of a red viscous liquid. This remained mobile after cooling to room temperature sodium hydroxide (0.15 mole in 25 ml water) and formaldehyde (0.15 mole 37%^W/W solution) was then added to the residue. After refluxing the mixture for 60 minutes, analysis of the reflux return indicated that all the formaldehyde had been consumed. The mixture was cooled to room temperature and neutralised with 10% sulphuric acid to give ~30 gm of a reddish brown oil. This was soluble in p-xylene, but insoluble in I.M.S. acetone and water.

A strip of bleached Kraft paper was impregnated manually with a solution of the resin in p-xylene (20%^W/W) in a small flat tray. The impregnated paper (45% resin content) was dried for 5 minutes at 135°C in a forced air oven. Four ply strips (nominally 4" x 2"), 10.16 x 5.08 cm. of the dried paper were pressed for 15 minutes at 160°C/1000 p.s.i. (6.997 MN/m²) in a manually operated Apex laboratory press. The dark brown coloured laminate was paperlike in character and could easily be delaminated by hand. Post curing in an oven for 2 hours at 135°C followed by 66 hours at 105°C resulted in a harder, more brittle material, which delaminated less readily. Further post curing produced no apparent change in laminate appearance or properties.

Immersion in acetone, I.M.S. and p-xylene for 24 hours similarly had no effect on the laminate.

This experiment was repeated using p-cresol instead of p-cresyl methyl ether. The resulting polymer was soluble in acetone only and, therefore, had to be applied in this solvent. The post cured laminate showed less tendency to delaminate and was similarly unaffected by solvents.

These preliminary findings suggest that:-

1. A suitable method had been developed for preparing methylated resins.
2. A stronger interlaminar bond exists in the p-cresol laminate than in its methyl ether analogue.

8. 5. MANUFACTURE OF XYLOK TYPE LAMINATES.

8. 5. 1. EXPERIMENTAL.

Laminates were made from resins based on p-cresol and p-cresyl methyl ether. Preparative details were identical to those described in Section 8.4.1. Additional information regarding processing controls are outlined in Appendix 2. The resins were prepared on a one molar scale and for completeness the relevant molar ratios of the base constituents are described in Table 17.

TABLE 17. XYLOK RESIN FORMULATION.

| REACTENTS. | MOLAR RATIOS. | |
|-------------------------------|---------------|----------|
| | RESIN S. | RESIN T. |
| p-cresol:phenol. | 3:1. | - |
| p-cresyl methyl ether:phenol. | - | 3:1. |
| Total aromatic\p-X.G.D.M.E. | 1:1.2. | 1:1.2. |
| Phenol\ formaldehyde. | 1:1.45. | 1:1.45. |
| Phenol\ Sodium hydroxide. | 1:1. | 1:1. |

8. 6. PROPERTIES OF XYLOK TYPE LAMINATES.

Laminates based on the p-cresol formulation were satisfactory in appearance and suitable for sampling techniques. However, the methyl ether based material displayed delamination effects to such an extent that total assessment of mechanical properties was clearly out of the question. Although there was obviously a considerable difference in the strengths of the two laminates, short beam shear testing was carried out at room temperature.

This was done in an attempt to assess the relative magnitude of the interlaminar shear strengths of the resins, S and T respectively. The testing procedure outlined in earlier chapters was again followed.

INTERLAMINAR SHEAR STRENGTH OF LAMINATES S AND T.

Table 18 gives the interlaminar shear strengths of resins S and T respectively.

TABLE 18. INTERLAMINAR SHEAR STRENGTHS (γ) OF RESINS S AND T.

| RESIN. | (MN/m ²) |
|--------|----------------------|
| S. | 28. |
| T. | 2.5. |

It is clear from the table that the effect of "blocking" the p-cresol phenolic hydroxyl group is to reduce, considerably, the interlaminar shear strength. Thus it appears that the resin-paper bond has been effectively weakened. Although this result could in part be a consequence of reduced comparibility of resin to paper (at the impregnation stage) it is thought that this effect alone is insufficient

to account for the observed tenfold reduction in shear strength.

This particular section was given a low priority in the overall scheme of work presented in this thesis. Therefore, no further work was carried out on paper-resin interactions. However, the following conclusions may be inferred at this stage based on the present findings:-

1. A system suitable for investigating paper-resin interactions has been developed.
2. Preliminary results suggest the existence of secondary forces between phenolic hydroxyl groups and paper base.
3. Short beam testing provides an effective method for assessing paper-resin bond strengths on a comparative basis.
4. The approach outlined in this chapter could be used as a basis by which knowledge in this area of the field could be extended.

In view of the work done on substituted propane, a fuller discussion on the subject of secondary forces will be dealt with in Chapter 9.

--O-O-O-O-O-O-O-O--

CHAPTER 9.DISCUSSION.SECTION 9.1. EXAMINATION OF PROCEDURE ADOPTED.

The testing methods selected for this investigation have provided a great deal of information about the performance of these laminated materials. Further, it has been possible in many cases to present ideas on how structural features of the resin may affect these properties. Although none of these test methods are unique in the field of phenolic laminates, there is little evidence to suggest previous attempts to systematically investigate structure-property relationships of these materials.

Watson⁽¹⁾ was able, from his limited results on the subject, to make some general comments about the influence of chemical structure on mechanical properties. He noted for example that as the density of crosslinks (apparently present) decreased, there was an overall improvement in punching quality. Watson's notable achievements centred on the development of the instrumented punching press.

The results of this work have, to some extent, confirmed his (Watson) preliminary comments and tentative predictions. In view of his main objective it is with some respect that his contribution to the field is acknowledged.

This work then presented an opportunity for future developments in this area. As work progressed it became clear that supporting techniques would be necessary to furnish a more detailed view on structure-property relationships.

The development of the instrumented power press enabled the

mechanism of the punching process to be re-examined and the effect of various processing variables to be investigated. The first point is really beyond the scope of this thesis. It appears, however, that the explanation given is satisfactory although to some extent empirical in its nature. The second objective was readily achieved since gross differences in mechanical properties were being examined. The technique seems rather unsatisfactory for measuring minor structural differences in the resin and more sensitive techniques are clearly desirable. In the study of molecular structure his results suggested minor differences in stress to break values, although strain results were significantly higher. The general shapes of the punching curves (stress-strain plots as a function of time) are rather similar in appearance. Hence it is difficult to see how minor differences in the structure of these curves can be correlated to various molecular features of the resin. In addition the technique is rather time consuming and barely justifies its limited output of useful information. The visual assessment technique, although clearly subject to gross personal errors on the part of the operator, does provide a useful general assessment of the material. Any punching test must clearly include such an assessment since quality of the finished product is one of the primary requirements of the laminator's customer. In this work punching quality (P.Q.) has been assessed and shown to provide a close relationship with chemical structure. In addition there was good correlation with other mechanical properties measured. In view of the empirical basis of P.Q. determination this was rather surprising but was nevertheless, regarded as a welcome bonus. In private communications with Watson⁽⁸⁷⁾ it was generally agreed that an

appreciation of mechanical moduli would be most useful. Prior to surface penetration the laminate flexes under the influence of the punch load, thus a knowledge of the "flexibility" of the material would not only aid assessment of the material "punchability" but could also be used as a tool in examining structural control methods.

The flexural test is not only rapid but can be carried out with limited operator skill (the instrumented punching test by no means achieved this requirement). Further, it provides an assessment of the behaviour of the material under loaded conditions prior to breaking. Consequently a knowledge of its limitations in end use application is determined. In addition properties to break in terms of stress and strain are readily available. The latter providing a rough assessment of material toughness and hence its ability to absorb energy under load.

Dynamic mechanical property evaluation provided a great deal of information not only regarding punching properties, but more importantly chemical structure. At higher temperatures there was good correlation of properties with structure. This was particularly noticed with the p-cresol | phenol system. The success of the technique in demonstrating the effect of alkyl substituents in the aromatic ring was quite notable. The limited application of the technique at lower temperatures may be ascribed to the highly elastic nature of the laminate under these conditions. Therefore, as expected in a highly crosslinked system, damping was low and shear modulus lacked significant temperature dependence.

The short beam shear test was used primarily as a means for assessing paper resin interactions. This provided direct correlation

with the flexural test results which suggested that flexural components contributed to the shear moment to a greater degree than theory would suggest. However, the technique was useful within its recognised limited scope.

A secondary objective to the study of structural property relationships was to gain a deeper understanding of the type of material properties associated with punching performance. At this point it would be useful to see how far this objective was achieved.

9. 2. ANALYSIS OF MECHANICAL PROPERTIES.

The phenol/p-cresol system has been assessed by the techniques mentioned in Section 9.1. and, therefore, the results from this section are drawn upon for examination. For convenience the points made in Section 5.4.5. are repeated:-

1. P.Q. increases with punching temperature.
2. P.Q. increases with cresol content.
3. The temperature dependence of P.Q. becomes less marked as cresol content increases.

In addition:-

4. P.Q. generally decreases with shear modulus (G).
5. P.Q. increases with mechanical damping (Δ).
6. P.Q. increases with flexural strain at break.

Points 4, 5 and 6 are illustrated in Figures 55, 56 and 57.

Here dynamic test results have been plotted as a function of P.Q. at 120°C.

As pointed out earlier, less emphasis is made of low temperature testing under dynamic conditions. Point 6 is illustrated in Figure 55. Here flexural strain to break has been plotted as a function of P.Q. at 25°C.

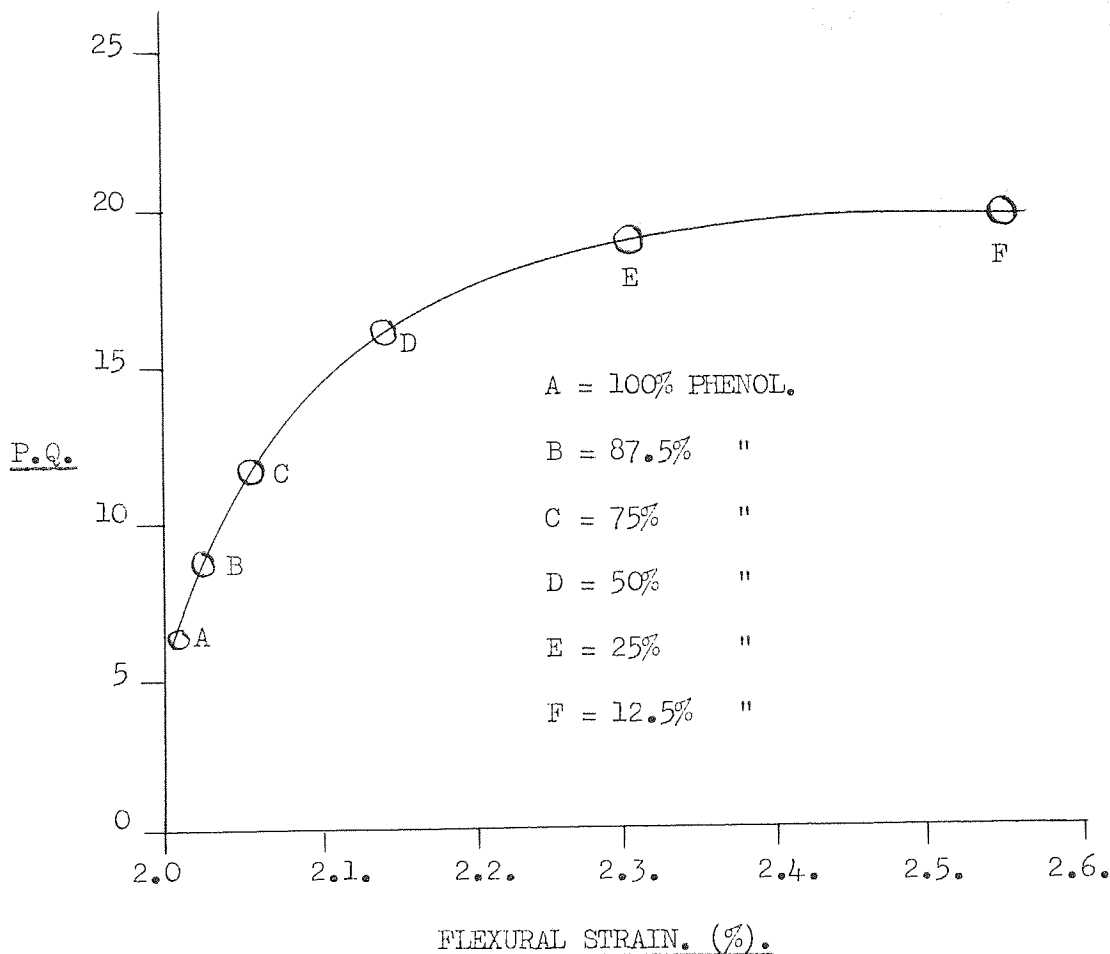

FIGURE 55. P.Q. AS A FUNCTION OF FLEXURAL STRAIN. (25°C).

The flexural modulus and stress data is more complicated to handle. As the phenol content is increased these values increase until a level corresponding to about 50% phenol is reached. On either side of this region these properties gradually decrease. However, P.Q. steadily decreases as phenol content is increased. Thus it seems that P.Q. is not directly related to flexural properties. Similar conclusions are reached from the short beam shear values. The results do suggest, however, that a good punching resin is one possessing a limited number of achieved crosslinks, a high degree of flexibility and of low ultimate strength. If strength or stiffness is the primary requirement then apparently this may be obtained with some sacrifice in punching

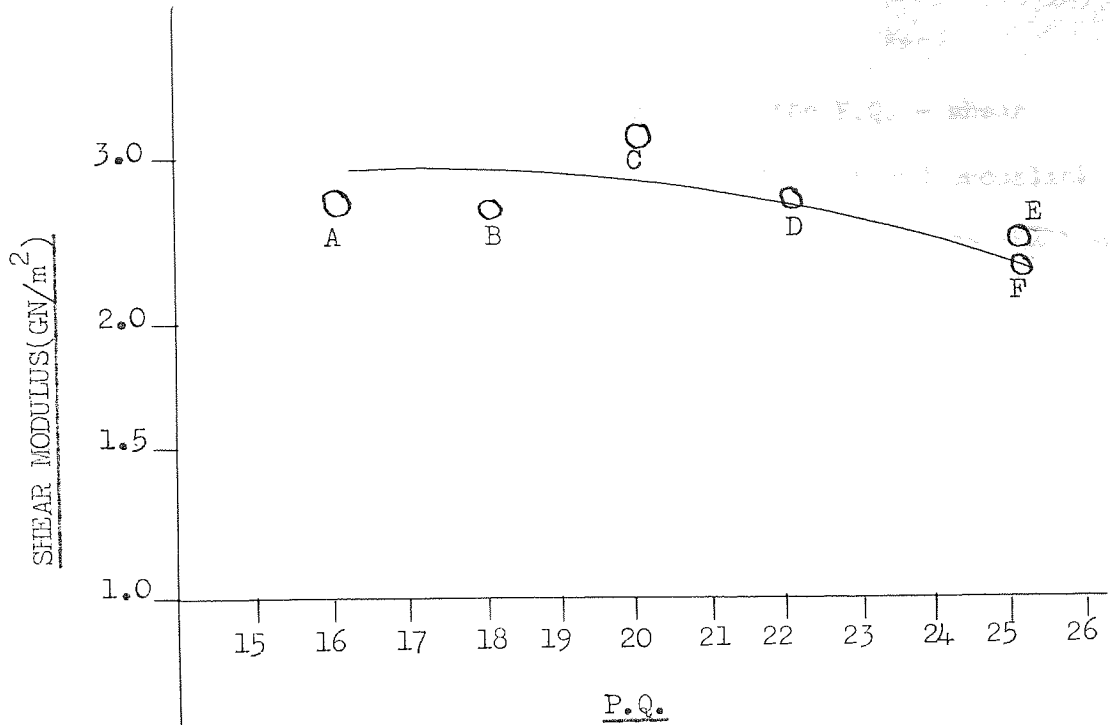

FIGURE 56. P.Q. AS A FUNCTION OF DYNAMIC SHEAR MODULUS.

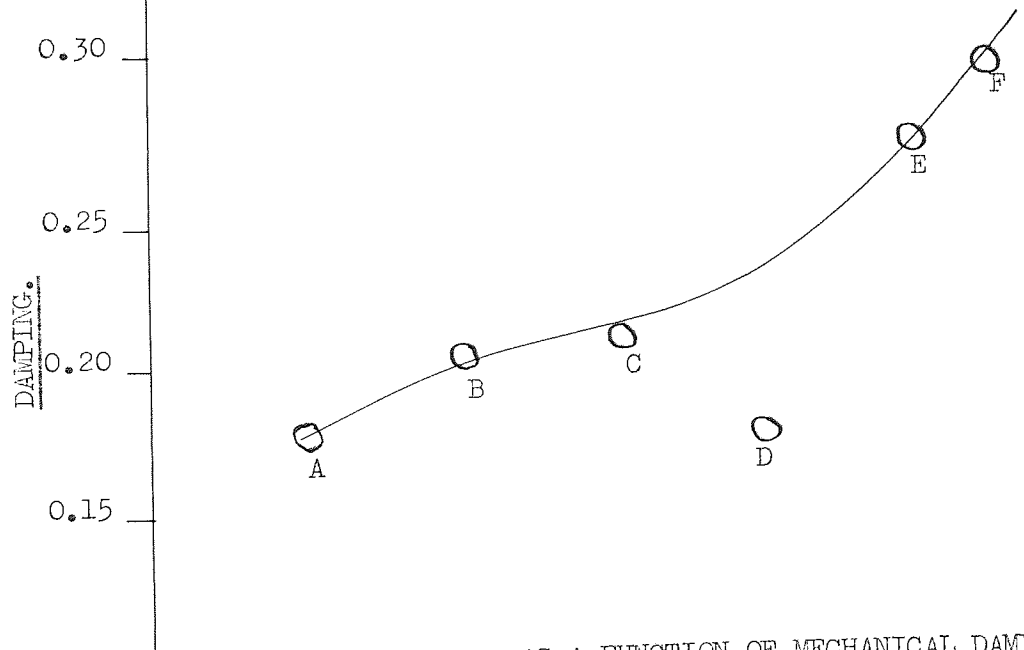

FIGURE 57. P.Q. AS A FUNCTION OF MECHANICAL DAMPING.

Referring to Figures 56 and 57:-

A = 100% PHENOL.

B = 87.5% "

C = 75% "

D = 50% PHENOL.

E = 25% "

F = 12.5% "

quality. Similar conclusions may be made from the P.Q. - shear modulus curves. Generally P.Q. increases as rigidity and crosslink density decreases. In conclusion a material possessing good punching characteristics is one which can absorb a great deal of energy and possessing high flexibility and low ultimate strength.

In choosing a punching material it seems clear that two factors must be considered.

1. Punching temperature.
2. End use performance.

Taking Point 1, it seems from Figures 41, 42, that the following criteria must be considered when equating resin formulation with punching conditions. (See Table 19).

TABLE 19. PHENOL CONTENT AS A FUNCTION OF PUNCHING TEMPERATURE.

| DESCRIPTION OF LAMINATE. | PUNCHING TEMPERATURE. (°C) | MAXIMUM DESIRABLE LEVEL OF PHENOL. |
|--------------------------|----------------------------|------------------------------------|
| Cold punching. | 20 | 25% |
| Medium punching. | 90 | 50% |
| Hot punching. | > 100 | 75% |

Referring to Point 2, a compromise must be made between ultimate properties (e.g. strength in flexure) and toughness (the ability to absorb energy). Taking an overall view of the situation a formulation where phenol/p-cresol equals 1:1 seems an attractive compromise. Here satisfactory P.Q. is available, strength and modulus values are at a maximum and damping attains a reasonable level. Below 50% phenol the thermoplasticity of the resin rapidly increases and although P.Q. is good other mechanical properties are inferior.

The poor punching properties of pure P/f resins is readily understood. The material is both brittle and weak in strength. Its ability to absorb energy is strictly limited and thus defects on the punched surface are extensive. Only at very high temperatures (about 160°C) can a reasonable punch contour be achieved.

In most phenol/p-cresol resins the temperature dependence of P.Q. is fairly easy to explain. At high cresol contents the structure is thermoplastic in nature. Ortho-ortho bonding will be extensive in this region, but the effect due to this is offset by the increased degree of rotation about essentially linear phenol-methylene chains. At about 110°C a transition region is observed. This is probably due to a reduction in secondary bond forces (corresponding to an increase in segmental motion). This transition region has been demonstrated by the dynamic mechanical testing results. As the phenol content increases, segmental motion, even at higher temperatures, is restricted and the material will punch in a brittle fashion. It has been suggested earlier that at very high phenol contents, crosslinking is limited and there is a possibility that stress concentration areas constitute points of weakness in the system leading to inferior punching properties.

9. 3. VISUAL EXAMINATION OF THE PUNCHED SURFACE (1).

(a) Crack propagation defects. (1).

These defects include feathering and cracks to the edge of the test piece. It is thought that these arise from unrestricted propagation of cracks due to the brittleness of the material. Feathering has been observed at all phenol/p-cresol ratios and seems to be a consequence of the inherent brittleness of laminated materials.

Cracks to edge are not featured in the higher cresol content laminates, presumably because the increased damping of these materials restricts this propagation by segmental toughening. This suggestion is supported by Keeling⁽⁸³⁾ who assessed laminated materials in terms of punching and dynamic mechanical measurements. He came to similar conclusions regarding punching quality and its dependence on toughness.

(b) Yield defects.

These include haloing and tensile cracking. The latter was assumed to have originated from the radial tensile stress operating in the top surface of the test piece around the edge of the punch. Haloing was said to have similar origins except that stress relief occurred by ply separation within the material close to the sheared edge. Learmonth and Watson⁽¹⁾ have shown that these defects could arise not only from a lack of flexibility, but in some cases also from too much flexibility. The present work supports this view since haloing was observed even at higher cresol contents and was absent only in the 12 $\frac{1}{2}$ % phenol resin. In a general study of resin structure these defects can only be used on a qualitative basis. A more balanced view is perhaps that they are both defects inherent in any punching laminate irrespective of attempts of structural control.

These points then consolidate previous comments; namely that tougher or conversely less brittle materials possess superior punching properties. As the brittleness of the resin increases, it is no longer able to act as a shock absorber to the applied punch load. Consequently energy dissipation is taken up by the filler and delamination/tensile failure effects account for this stress relief.

This is readily observed by visual assessment of the punched specimen.

9. 4. PAPER-RESIN INTERACTIONS.

In view of the amount of time spent on this section, the results appear to be rather dissapointing in their content. Although the general technique of resin preparation was successfully developed, satisfactory processing conditions for laminate preparation was not fully established. This was due to two factors:-

1. This section was given a low priority in the overall scheme of the project and, therefore, the time available for this work was limited.
2. The xylok type of resin is difficult to process. The incompatibility of the methoxy group with cellulosic OH groups reduces the wetting ability and hence the absorbing power of the paper. The resulting laminate is extremely "crumbly" in nature and thus sampling is difficult.

The hydroxylated resin cures satisfactorily giving rigid laminates possessing a high interlaminar bond. If the chemical approach is considered it might be assumed that hydrogen bonding is eliminated in the methylated resin and, therefore, paper-resin interactions are minimised. It is surprising, however, to find that the shear strength of the two resins differ so significantly. It seems likely that such differences are due not only to a reduction in secondary bond forces but to some extent to reduced absorbency of the resin to paper.

Since a suitable resin has been synthesised for this study, the field is now open for future development. Secondary forces appear to play a part in resin-paper interactions and, therefore, it might be

worthwhile developing more refined processing techniques to enable reliable correlations to be made.

9. 5. RESIN BASED ON 1, 3-SUBSTITUTED PROPANE.

The limited amount of material available for sampling precluded an assessment of punching properties. It is thought, however, that the material would have good medium temperature punching properties in view of its damping behaviour and high strain to break values in this temperature range. The work of Korshak⁽⁶²⁾ may be remembered here. He noted that impact strength increased as the number of methylene bridges between adjacent phenolic groups increased. It is generally recognised⁽³⁵⁾ that the close approach of phenolic hydroxyl groups in ortho-ortho linked resins encourages intra molecular hydrogen bonding. If the Drieding type of model of 1,3-di (o-hydroxyphenol) propane is examined, it will be seen that such close approach of the phenolic hydroxyl groups is not so readily achieved. Thus, it seems that hydrogen bonding will be limited in most of the conformations possible for the molecule. The use of such models must, of course, be treated with extreme caution, since they by no means represent a true picture of the cured resin where certain conformations will be unlikely from steric considerations. However, it is clear that the molecule possesses more elements of rotational freedom than the conventional dihydroxy diphenyl methane analogue and it is certain to introduce centres of increased molecular flexibility and reduced secondary force fields to the system.

It is interesting to compare the influence of resin properties of propane and p-cresol respectively. The latter apparently possesses the ability to open out the resin structure, thus allowing a greater

number of crosslinks to be achieved. Thus within a limited range, the molecule has the ability to stiffen up the network despite its difunctionality which would in theory suggest the converse effect.

In conclusion it has been shown so far that molecular flexibility may be controlled by any one of the following factors:-

1. Varying the number of crosslinks.
2. Copolymerisation with monomers incorporating in-built elements of rotational freedom.

9. 6. SUBSTITUTED RESINS.

General comments regarding these resins have already been made in Chapter 7. and, therefore, an overall view only is required here.

It is clear from the results that the effect of alkyl substituents on the phenolic nucleus is an improvement in punching quality at 70°C. Further, these groups seem to act as internal plasticising agents by increasing flexibility and toughness in terms of mechanical damping. However, these properties may be similarly controlled by the use of phenol/p-cresol blends. Commercially use of the latter resins is more viable since the increase cost of some substituted resins offsets any mechanical advantages gained by their use.

9. 7. FINE STRUCTURE OF RESIN.

The structure of "cured" phenolic resins has been examined and discussed for over half a century. There have been many suggestions put forward about this, the most complex area of phenolic resin chemistry. Some of these have been briefly reviewed in Chapter 2. From the extensive literature available the views of Megson and Pritchett⁽⁴³⁾ seems to provide the most reasonable basis for discussion,⁽⁸⁸⁾

since their ideas probably provide the closest approach to the solution. Their method of approach differs but the overall conclusion they reach is remarkably similar. This is defined simply by the statement that a limited number of crosslinks is actually achieved in the cured resin. In this discussion the terms "cure" and "hardened" are used to describe the state of the generally accepted form of the so-called "C" stage resin.

Megson opens his argument by pointing out that a planar arrangement of phenol-methylene rings is improbable if the radii of the aromatic carbon atoms is taken into account. His point is that carbon atoms in adjacent benzene rings would effectively overlap in the planar form of diphenyl methane (D.P.M.). He suggests that the geometry of the D.P.M. molecule may be depicted by a "bracket" in which steric relief would be at a maximum. Extending the argument to higher molecular weight material, he pictures the system as a highly kinked arrangement of phenol-methylene chains. It was noted that in such an arrangement it is sterically impossible to form additional crosslinks due to the hindered approach of other molecules and chains. He concludes that "on probability grounds a completely crosslinked structure (phenol:methylene = 2:3) is most unlikely".

Pritchett appeals for a clearer definition of a "hardened" resin. He points out that the quality control tests used in industry to determine this state are largely empirical. Further, it is noted that there is little correlation between these tests and resins based on different phenols. He views the process on a physical basis and concludes that hardening is primarily a consequence of molecular entanglement rather than by the formation of primary bonds in a 3

dimensional bound network. His concept of the process is defined in the following manner:- "A simple chain grows and then at a few points on that chain other chains condense to form branches. This proceeds until hardening is completed. Initially the resin is soluble but as the branches and separate molecules begin to entangle due to their size, movement is restricted. Further hardening causes more entanglement and the resin molecules become immobile and therefore insoluble".

Results from the present work certainly seem to suggest that crosslinking is less than the maximum theory would permit. This has been illustrated by the phenol/p-cresol system where resins based on certain blends displayed greater stiffness (in terms of modulus) than those from phenol alone. It has been contended here that p-cresol has the ability to create a more open network. Thus from a steric point of view crosslinking would be less hindered. Taking up Pritchett's ideas, it is possible that as the proportion of phenol is increased the incidence of potential branching sites also increases. Therefore, entanglement of branched chains is now enhanced. At high phenol|p-cresol ratio there is a notable reduction in strength and modulus in flexure. Presumably branching and thus entanglement is less here, perhaps by branch formation being sterically hindered.

The general phenomenon of entanglement has been used to explore the anomaly of the p-cresol /formaldehyde resin cure. It was noted in Chapter 5 that p-chlorophenol resins do not cure whereas p-cresol resins may be used to make a weak, if unsatisfactory, laminate. It is surprising that p-chloro phenol methylene chains are incapable of entangling and thus hardening as efficiently as the p-cresol resin.

The formation of quinone methides has been suggested to explain a source of added functionality in ortho and para alkyl substituted phenols under curing conditions. It has been noted that these molecular entities (or diradicals) are capable of polymerisation resulting in the formation of dimers and trimers. Thus extensive branching could be brought about if quinone methides were generated at one end of a resin molecule. However, if in addition methides were formed at other points of the resin molecule, true crosslinking could be obtained. It has been suggested⁽⁸⁴⁾ that p-cresol might provide a source of quinone methide by oxidation reactions. For example Pummerer⁽⁸⁵⁾ has obtained these diradicals by the oxidation of tetrachloro-p-cresol. (See Figure 58).

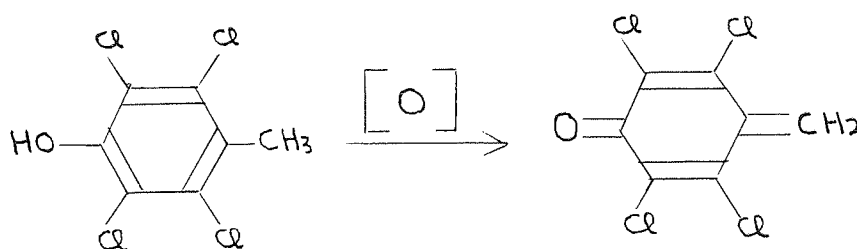

FIGURE 58. OXIDATION OF TETRA-CHLORO p-CRESOL.

Further Von Euler and de Kiszeczy⁽⁸⁶⁾ have suggested that p-methides lead to the formation of stilbenes and dihydroxy diphenyl ethanes. Admittedly quinone methides are shortlived species and, therefore, their involvement in resin curing reactions is still somewhat speculative. It was mentioned in Chapter 3 that other mechanisms have been postulated to explain these anomalies. However, concrete experimental evidence is sadly lacking to support these

views and, therefore, they must be given low priority.

It is generally accepted⁽⁵⁵⁾ that certain substituents may reduce the degree of rotation about the methylene bridge. The work here suggests that ortho methyl substituted resins possess less rigidity than either phenol or phenol/p-cresol (1:3). It seems then that steric hinderance discourages a high degree of crosslinking in these resins. However, the formation of highly kinked chains from these phenols should enhance entanglement leading to stiffer networks than from simple phenol alone.

The view contended here is that the degree of hardening and thus the physical properties of the cured resin is primarily dependent upon the number of chemical crosslinks actually achieved in the system. Chain entanglement will undoubtedly be involved to some extent in the curing process but its influence on physical properties will only predominate at high p-cresol contents.

In this field any theory concerning resin cure must be regarded as speculative. In this thesis conclusions have been drawn from the results obtained and by careful examination of other workers views. The complexity of resin forming reactions lend support to the view that the problem may be approached but never satisfactorily solved. In view of this it is so easy, and yet so unfair, to criticise anyone's attempt to throw light on the subject of resin structure.

The major theories suggested in this field probably all contribute to the overall picture. However, the degree to which one theory might contribute is highly speculative and indeed may vary from one system to another.

9. 8. SPECULATIONS REGARDING FUTURE WORK.

In this work the use of the phenol/p-cresol system has produced a great deal of information on the effect of the apparent crosslink density. The logical development to this investigation would be an attempt to assess more accurately the number of chemical crosslinks actually achieved in the system. This would not only increase knowledge in the general field of resin structure-property relationships, but would also throw further light on the resin fine structure. Both these facets could be more sensibly examined if the resin was investigated in the form of a thin film. Any errors introduced by impregnating in the laminating stage would then be eliminated. Further the cured resin would be made more accessible for examination and mechanical properties would not be masked by the substantial contribution due to the paper filler. Dynamic mechanical properties could then be more accurately assessed using the fully instrumented "Rheovibron" which provides a facility for the direct reading of $\tan \delta$. In addition a torsional braid technique could be used to assess a deeper understanding of the curing profile of the resin. Chemical analysis of the hardened resin is admittedly an unenviable task. Possibly attempts centred around molecular weight determinations and elemental analysis might provide some useful knowledge⁽⁶¹⁾.

The work done on 1,3-di-(o-hydroxyphenyl) propane could easily be extended by similar synthetic techniques to include other substituted n-alkanes. In addition the synthesis of p-hydroxy phenyl alkanes would provide a useful test of Doroshenko's⁽⁶²⁾ work. This type of investigation would provide in greater depth knowledge of the significance of intramolecular hydrogen bonding in the resin matrix.

Resin-paper interaction was an aspect of the field only briefly examined in this thesis. However, sufficient background work was done to provide a reliable basis for future work. This could easily include a more systematic study based on the "Xyllok" resins developed here. In addition some attention should be focussed on the paper itself. This might include paper based fillers, incorporating blocked hydroxyl groups, different types of paper and modification of surface properties by external sizing techniques. Thus extensive work could be carried out in an attempt to gain a deeper understanding of interlaminar properties.

It would be interesting to clear up the question regarding the influence of the meta-isopropyl group. Although separation of the meta/para isomers would be tedious, such a project might be worthwhile.

The result of this work, together with Watson's, has shed light regarding the pertinent features which may affect punching quality. Further work in this direction should be done in conjunction with industry so that commercial requirements are satisfied. Undoubtedly, further investigations involving blends of phenols and cresols would be worthy of industrial consideration.

There has always been a great deal of talk concerning the synthetic approach to resin structure/property investigations. Whilst this idea is attractive, it has been shown here to be impractical technologically. However, investigations using thin films would lend greater feasibility to such an approach in view of the lower quantities of material required. The literature is replete with suggestions of "model" systems capable of synthesis. Of these the work of Burke^(59, 60) and Kammerer⁽⁶¹⁾ appear to be of most interest. It is clear that the use

of their polymers incorporating some knowledge of chemical structure would help elucidate structure/property relationship.

Watson chose cashew nut shell liquid (C.N.S.L.) as an example to illustrate the properties of a plasticised resin. From the academic point of view it would be interesting to discover the mode of plasticisation. Thus the question of whether this kind of plasticisation is physical or chemical could be established.

Whichever course this work takes in the future, it is contended here that technological consequences should bear a close relationship with the approach used in the investigation.

The needs of society today are such that any investigation of this type should bear some technological significance.

--O--O--O--O--O--O--O--O--O--

CHAPTER 10.CONCLUSIONS.

This work has provided evidence that certain features of the resin structure have a significant influence on the mechanical properties. The phenol/p-cresol system has been used to some success to provide a simple method for assessing the effect of changes in the apparent crosslink density. It has been shown that p-cresol tends to stiffen the phenolic resin network and that high molar ratios of p-cresol/phenol lends a high degree of thermo-plasticity to the resin.

The introduction of alkyl substituents to the phenol nucleus has a marked influence on the mechanical properties of the resin. This effect was shown to be a function of substituent bulk and position relative to the phenolic hydroxyl group. In general these substituents have an internal plasticising effect on the resin.

A synthetic approach has been explained to prepare a resin incorporating elements of increased rotational freedom. It was shown that this probably resulted in a reduction in the degree of intramolecular hydrogen bonding. This suggests that hydrogen bonding may contribute significantly to the inherent brittleness of the resin.

A resin has been developed to explore the area of paper-resin interactions. Preliminary results suggest chemical in addition to physical involvement of the resin. A testing jig is mentioned in an attempt to aid these investigations. It is suggested that interlaminary bond strength is partly a function of intermolecular hydrogen bonding.

Punching quality has been assessed for resins based on phenol

and substituted phenols. This data was supported by additional testing methods resulting in a greater knowledge of the resin structure.

It was shown that there is a correlation between P.Q., toughness, rigidity in shear and flexural strain to break. It was shown that P.Q. improves with toughness and flexural strain to break, but decreases with rigidity. Further it is thought that as P.Q. decreases, the paper filler assumes a greater responsibility as a shock absorber and visual defects consequently become more apparent.

Finally it is argued that the results presented in this thesis provide a firm basis for future work in this field.

--O--O--O--O--O--O--O--O--O--

ACKNOWLEDGEMENTS.

The author would like to thank the following people for their assistance during the course of this project:-

Dr. G. S. Learmonth, who initiated this work and whose kindness and encouragement during the last three years has been greatly appreciated.

Dr. B. J. Tighe, for kindly lending supervision during Dr. Learmonth's Sabbatical year.

Dr. Janet Scott, for the loan of the short beam shear testing jig.

To the Technical Staff of the University.

To Midland Yorkshire Tar Distillers Company, who provided financial support for this project.

Finally, to Mrs. T. C. Spragg, whose patience and endeavour in typing this manuscript has been most appreciated.

APPENDIX.1.CONTROL METHODS FOR RESIN PREPARATION, PAPER IMPREGNATION
AND DRYING.Method 1. Determination of formaldehyde content of
distillate return.

This method depends on the quantitative liberation of sodium hydroxide when formaldehyde reacts with sodium sulphite.

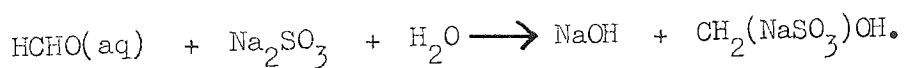

50 ml of a molar solution of sodium sulphite, together with three drops of thymolphthalein indicator solution were neutralised with normal sulphuric acid to a colourless end-point. This was added to 2.0 ml of the distillate return, which had been measured with a pipette, diluted with 10 ml of distilled water and neutralised to thymolphthalein. The mixture was titrated slowly with the standard acid to a colourless end-point.

1 ml of normal acid is equivalent to 0.0300 g of formaldehyde,

therefore, the formaldehyde content of the distillate

$$\text{return} = \frac{\text{Acid titre} \times 0.0300 \times 100.}{2.0.} \%$$

$$= \text{Acid titre} \times 1.5\% \text{ w/v (for normal acid).}$$

Method 2. Determination of solids content of resin solution.

25.0g of acid-washed silver sand (44-85 mesh) was placed in a circular aluminium dish (6 cm diameter). These were placed in a forced circulation hot-air oven at 135°C for 60 min and then weighed (to the nearest mg.) after cooling in a desiccator. 1.0 g of resin solution was weighed onto the sand from a polythene dropper bottle. The weight of the bottle (to the nearest mg.), before and after, was used to minimise evaporation effects. The resin was then dispersed on the sand by stirring 7 ml of acetone into the mixture with the steel rod. The dish was placed on top of the oven for 15 min to evaporate most of the solvent and then placed inside the oven (still at 135°C) for 120 min. The dish was placed in a desiccator to cool and then weighed (to the nearest mg.). The determination was carried out in duplicate and the arithmetic mean of the results used.

Weight of dish + sand + rod = W_1 ,

weight of resin solution = W_2 and

weight of dish + sand + rod + resin (after 120 min at 135°C) = W_3 ,

therefore, solids content of resin solution =

$$\frac{W_3 - W_1}{W_2} \times 100\%$$

Method 3. Determination of resin content and volatile content of impregnated paper.

One 5 cm square of untreated paper and another of impregnated paper were cut and weighed (to the nearest mg). The impregnated paper was hung in a forced circulation hot-air oven at 150°C for 5 min, then removed and weighed immediately (to the nearest mg).

Weight of untreated paper = W_4 ,

weight of impregnated paper = W_5 and

weight of impregnated paper (after 5 min at 150°C) = W_6 ,

therefore, resin content of impregnated paper =

$$\frac{W_6 - W_4}{W_5} \times 100\% \text{ and}$$

volatile content of impregnated paper =

$$\frac{W_5 - W_6}{W_5} \times 100\%$$

Method 4. Determination of flash value of impregnated paper.

Four 5 cm squares of impregnated paper were cut and weighed together (to the nearest mg). The squares were stacked and placed between 8 cm square of aluminium cooking foil. This pack was then placed between 15 cm squares of cellophane film and pressed for 5 min at 150°C and 6.9 MN/m² in a hand operated laboratory hydraulic press. The pack was then removed from the press, allowed to cool and the cellophane and foil removed. Flash was removed from the edge of the test laminate by scraping it lightly, twice, with the edge of a piece of rejected laminate. The test laminate was then weighed (to the nearest mg.).

Weight of the four squares = W_7 and

weight of the laminate = W_8 ,

therefore, flash value of the impregnated paper =

$$\frac{W_7 - W_8}{W_7} \times 100\%$$

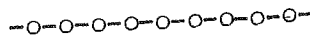

APPENDIX 2.LAMINATE SPECIFICATION.CHAPTER 5.PHENOL/p-CRESOL RESINS.

| PHENOL. (%) | CONTS. (%) | VOLS. (%) | FLASH. (%) | DRYING TEMP: (°C) | DRYING TIME. (Mins) | NO. IMPREGNATIONS (1 x 50% SOLUTION 2,3,4 x 25% ") |
|----------------|---------------|--------------|---------------|-------------------------|---------------------------|---|
| 12.5. | 40.6. | 5.7. | 7.1. | 100. | 20. | 3. |
| 25. | 41.0. | 3.5. | 9.1. | 109. | 40. | 2. |
| 50. | 40.2. | 6.6. | 9.4. | 85. | 35. | 2. |
| 75. | 41.0. | 7.3. | 9.6. | 91. | 25. | 2. |
| 87.5. | 41.0. | 5.4. | 9.7. | 85. | 20. | 2. |
| 100. | 42.1. | 4.3. | 6.3. | 85. | 15. | 4. |

Continued:-

| PHENOL. (%) | THICKNESS. (mm). | DENSITY. (gm/cc). |
|----------------|---------------------|----------------------|
| 12.5. | 1.27. | 1.43. |
| 25. | 1.19. | 1.40. |
| 50. | 1.25. | 1.40. |
| 75. | 1.25. | 1.43. |
| 87.5. | 1.27. | 1.42. |
| 100. | 1.30. | 1.39. |

CHAPTER 6.SUBSTITUTED PARAFFIN.

| CONTS. (%) | VOLS. (%) | FLASH. (%) | DRYING TEMP: (°C) | DRYING TIME. (Mins) | THICKNESS. (mm). | NO. IMPREGNATIONS (1 x 50% SOLUTION) |
|---------------|--------------|---------------|-------------------------|---------------------------|---------------------|---|
| 42.5. | 4.1. | 4.0. | 85. | 20 | 1.21. | 1. |

CHAPTER 7.SUBSTITUTED RESINS.

| PHENOL. | CONTS. (%) | VOLS. (%) | FLASH. (%) | DRYING TEMP: (°C) | DRYING TIME. (Mins.) | NO. IMPREGNATIONS (1 x 50% SOLUTION) |
|---------------------|---------------|--------------|---------------|-------------------------|----------------------------|---|
| o-methyl | 42.1. | 6.5. | 11.8. | - | - | 1. |
| m-methyl | 45.1. | 6.3. | 11.2. | 85. | 5. | 1. |
| m/p-iso- propyl. | 43.7. | 4.0. | 12.1. | 85. | 30. | 1. |

Continued:-

| PHENOL. | THICKNESS. (mm). | DENSITY. (gm/cc). |
|----------------|---------------------|----------------------|
| o-methyl. | 1.4. | 1.35. |
| m-methyl. | 1.32. | 1.41. |
| m/p-isopropyl. | 1.27. | 1.37. |

CHAPTER 8."XYLOK" RESINS.

| RESIN. | CONTS. (%) | VOLS. (%) | FLASH. (%) | DRYING TEMP: (°C) | DRYING TIME. (Mins.) |
|-------------------------------|---------------|--------------|---------------|-------------------------|----------------------------|
| p-cresol | 38. | 2.2. | 12.1. | 135. | 10. |
| p-cresyl methyl/ ether. | 35. | 3.5. | 14.2. | 135. | 13. |

Continued:-

| RESIN. | No. IMPREGNATIONS. (50% SOLUTION). | THICKNESS. (mm). |
|------------------------------|---------------------------------------|---------------------|
| p-cresol | 2. | 1.4. |
| p-cresyl methyl ether. | 2. | 1.31. |

CHAPTER 4.

Laminate used in assessing the effect of span/depth ratio on interlaminar shear strength.

Pirtoid D. 1/16. in. thick grade, MP.300.

(Tufnol brand).

APPENDIX 3.TABULATION OF MECHANICAL TEST RESULTS.

The results presented in this thesis are in S.I. units according to the B.S.I. nomenclature.

For convenience the relationship between p.s.i. and N/m^2 is given in Figure 59.

CHAPTER 5.PHENOL/p-CRESOL RESINS.DYNAMIC MECHANICAL PROPERTIES.

| PHENOL. (%) | TEMPERATURE (°C) | SHEAR MODULUS (GN/m ²) | MECHANICAL DAMPING (Logarithmic decrement) |
|----------------|---------------------|---------------------------------------|---|
| 12.5. | 20. | 3.5. | 0.060. |
| " | 30. | 3.45. | 0.070. |
| " | 40. | 3.40. | 0.860. |
| " | 50. | 3.25. | 0.105. |
| " | 60. | 3.15. | 0.115. |
| " | 70. | 3.00. | 0.125. |
| " | 80. | 2.85. | 0.135. |
| " | 90. | 2.75. | 0.150. |
| " | 100. | 2.60. | 0.185. |
| " | 110. | 2.40. | 0.250. |
| " | 120. | 2.20. | 0.330. |
| " | 130. | 1.95. | 0.390. |
| " | 140. | 1.70. | 0.410. |
| " | 150. | 1.45. | 0.415. |
| " | 160. | 1.15. | 0.415. |

| PHENOL. (%) | TEMPERATURE (°C) | SHEAR MODULUS (GN/m ²) | MECHANICAL DAMPING (Logarithmic decrement) |
|----------------|---------------------|---------------------------------------|---|
| 25. | 20. | 3.75. | 0.550. |
| " | 30. | 3.70. | 0.550. |
| " | 40. | 3.60. | 0.550. |
| " | 50. | 3.50. | 0.570. |
| " | 60. | 3.45. | 0.600. |
| " | 70. | 3.30. | 0.640. |
| " | 80. | 3.15. | 0.720. |
| " | 90. | 3.00. | 0.110. |
| " | 100. | 2.80. | 0.160. |
| " | 110. | 2.55. | 0.180. |
| " | 120. | 2.25. | 0.195. |
| " | 130. | 2.00. | 0.205. |
| " | 140. | 1.70. | 0.220. |
| " | 150. | 1.45. | 0.250. |
| " | 160. | 1.25. | 0.330. |
| 50. | 20. | 3.60. | 0.950. |
| " | 30. | 3.45. | 0.980. |
| " | 40. | 3.30. | 0.990. |
| " | 50. | 3.25. | 0.100. |
| " | 60. | 3.20. | 0.105. |
| " | 70. | 3.10. | 0.110. |
| " | 80. | 2.90. | 0.120. |
| " | 90. | 2.80. | 0.120. |
| " | 100. | 2.70. | 0.120. |
| " | 110. | 2.65. | 0.120. |
| " | 120. | 2.55. | 0.120. |
| " | 130. | 2.50. | 0.115. |
| " | 140. | 2.35. | 0.105. |
| " | 150. | 2.25. | 0.110. |
| " | 160. | 2.10. | 0.145. |

| PHENOL. (%) | TEMPERATURE. (°C) | SHEAR MODULUS. (GN/m ²) | MECHANICAL DAMPING. (Logarithmic decrement) |
|----------------|----------------------|--|--|
| 75. | 20. | 4.60. | 0.088. |
| " | 30. | 4.35. | 0.096. |
| " | 40. | 4.20. | 0.110. |
| " | 50. | 4.00. | 0.130. |
| " | 60. | 3.80. | 0.150. |
| " | 70. | 3.60. | 0.150. |
| " | 80. | 3.40. | 0.150. |
| " | 90. | 3.10. | 0.155. |
| " | 100. | 3.00. | 0.160. |
| " | 110. | 3.00. | 0.160. |
| " | 120. | 3.00. | 0.150. |
| " | 130. | 3.00. | 0.145. |
| " | 140. | 2.95. | 0.140. |
| " | 150. | 2.85. | 0.135. |
| " | 160. | 2.75. | 0.140. |
| 87.5. | 20. | 3.55. | 0.066. |
| " | 30. | 3.45. | 0.078. |
| " | 40. | 3.20. | 0.088. |
| " | 50. | 3.10. | 0.094. |
| " | 60. | 3.00. | 0.098. |
| " | 70. | 2.90. | 0.110. |
| " | 80. | 2.85. | 0.135. |
| " | 90. | 2.75. | 0.140. |
| " | 100. | 2.60. | 0.145. |
| " | 110. | 2.50. | 0.145. |
| " | 120. | 2.45. | 0.140. |
| " | 130. | 2.50. | 0.125. |
| " | 140. | 2.50. | 0.110. |
| " | 150. | 2.45. | 0.115. |
| " | 160. | 2.30. | 0.135. |

| PHENOL. (%) | TEMPERATURE. (°C) | SHEAR MODULUS. (GN/m ²) | MECHANICAL DAMPING. (Logarithmic decrement) |
|----------------|----------------------|--|--|
| 100. | 20. | 3.20. | 0.096. |
| " | 30. | 3.10. | 0.098. |
| " | 40. | 2.90. | 0.100. |
| " | 50. | 2.75. | 0.100. |
| " | 60. | 2.70. | 0.105. |
| " | 70. | 2.50. | 0.105. |
| " | 80. | 2.45. | 0.110. |
| " | 90. | 2.40. | 0.110. |
| " | 100. | 2.45. | 0.115. |
| " | 110. | 2.55. | 0.120. |
| " | 120. | 2.65. | 0.120. |
| " | 130. | 2.70. | 0.105. |
| " | 140. | 2.70. | 0.920. |
| " | 150. | 2.60. | 0.910. |
| " | 160. | 2.50. | 0.960. |

FLEXURAL PROPERTIES.

| PHENOL (%) | TEMPERATURE (°C) | FLEXURAL MODULUS (GN/m ²) | FLEXURAL STRENGTH. (MN/m ²) | STRAIN AT BREAK. (%) |
|---------------|---------------------|---|---|-------------------------|
| 12.5. | 25. | 9.24. | 151. | 2.66. |
| " | 55. | 7.73. | 118. | - |
| " | 90. | 5.93. | 87.5. | - |
| " | 120. | 4.55. | 40. | - |
| 25. | 25. | 10.2. | 152. | 2.31. |
| " | 55. | 8.35. | 129. | - |
| " | 90. | 7.10. | 98.3. | - |
| " | 120. | 5.31. | 71.2. | - |

| PHENOL. (%) | TEMPERATURE. (°C) | FLEXURAL MODULUS. (GN/m ²) | FLEXURAL STRENGTH. (MN/m ²) | STRAIN AT BREAK (%) |
|----------------|----------------------|--|---|------------------------|
| 50. | 25. | 11.5. | 164. | 2.17. |
| " | 55. | 9.10. | 133. | - |
| " | 90. | 7.66. | 110. | - |
| " | 120. | 5.52. | 98.6. | - |
| 75. | 25. | 11.1. | 166. | 2.07. |
| " | 55. | 8.83. | 136. | - |
| " | 90. | 7.73. | 109. | - |
| " | 120. | 5.45. | 84.8. | - |
| 87.5. | 25. | 11.0. | 156. | 2.05. |
| " | 55. | 7.79. | 124. | - |
| " | 90. | 5.88. | 99.3. | - |
| " | 120. | 5.31. | 39.3. | - |
| 100. | 25. | 9.93. | 140. | 2.01. |
| " | 55. | 7.24. | 107. | - |
| " | 90. | 6.21. | 90.7. | - |
| " | 120. | 5.10. | 35.5. | - |

INTERLAMINAR SHEAR PROPERTIES. (AT 24°C).

| PHENOL. (%) | INTERLAMINAR SHEAR STRENGTH (MN/m ²) |
|----------------|---|
| 12.5. | 235. |
| 25. | 243. |
| 50. | 250. |
| 75. | 251. |
| 87.5. | 244. |
| 100. | 241. |

CHAPTER 6.SUBSTITUTED PARAFFIN RESIN.DYNAMIC MECHANICAL PROPERTIES.

| TEMPERATURE. (°C) | SHEAR MODULUS. (GN/m ²) | MECHANICAL DAMPING. (Logarithmic decrement). |
|----------------------|--|---|
| 20. | 3.40. | 0.08. |
| 30. | 3.40. | 0.10. |
| 40. | 3.30. | 0.115. |
| 50. | 3.10. | 0.140. |
| 60. | 2.80. | 0.155. |
| 70. | 2.70. | 0.170. |
| 80. | 2.60. | 0.185. |
| 90. | 2.55. | 0.195. |
| 100. | 2.50. | 0.185. |
| 110. | 2.50. | 0.160. |
| 120. | 2.40. | 0.130. |
| 130. | 2.35. | 0.130. |
| 140. | 2.30. | 0.120. |
| 150. | 2.30. | 0.120. |
| 160. | 2.50. | 0.115. |

CHAPTER 7.SUBSTITUTED RESINS.DYNAMIC MECHANICAL PROPERTIES.

| RESIN. | TEMPERATURE. (°C) | SHEAR MODULUS. (GN/m ²) | MECHANICAL DAMPING. (Logarithmic decrement) |
|---------------------------|----------------------|--|--|
| Ortho methyl phenol | 20. | 1.85. | 0.195. |
| | 30. | 1.75. | 0.250. |
| | 40. | 1.50. | 0.380. |
| | 50. | 1.20. | 0.800. |
| | 60. | 0.94. | 1.150. |
| | 70. | 0.74. | 1.100. |
| | 80. | 0.64. | 1.000. |
| | 90. | 0.54. | 0.940. |
| | 100. | 0.46. | 0.970. |
| | 110. | 0.40. | 1.150. |
| | 120. | 0.35. | 1.650. |

| RESIN. | TEMPERATURE. (°C) | SHEAR MODULUS. (GN/m ²) | MECHANICAL DAMPING. (Logarithmic decrement). |
|-------------------------------|----------------------|--|---|
| Meta methyl phenol. | 20. | 2.90. | 0.17. |
| | 30. | 2.60. | 0.19. |
| | 40. | 2.30. | 0.22. |
| | 50. | 2.00. | 0.26. |
| | 60. | 1.80. | 0.32. |
| | 70. | 1.55. | 0.40. |
| | 80. | 1.25. | 0.51. |
| | 90. | 0.92. | 0.66. |
| | 100. | 0.68. | 0.86. |
| | 110. | 0.53. | 0.88. |
| m/p-iso- propyl phenol. | 120. | 0.48. | 0.67. |
| | 130. | 0.45. | 0.52. |
| | 20. | 4.30. | 0.135. |
| | 30. | 4.10. | 0.150. |
| | 40. | 3.80. | 0.165. |
| | 50. | 3.60. | 0.190. |
| | 60. | 3.40. | 0.230. |
| | 70. | 3.20. | 0.320. |
| | 80. | 2.90. | 0.450. |
| | 90. | 2.65. | 0.595. |
| | 100. | 2.40. | 0.630. |
| | 110. | 2.20. | 0.560. |
| | 120. | 2.05. | 0.450. |
| | 130. | 2.05. | 0.360. |
| 140. | 2.10. | 0.300. | |
| 150. | 2.10. | 0.300. | |
| 160. | 1.90. | 0.500. | |

FLEXURAL PROPERTIES.

| RESIN. | TEMPERATURE. (°C) | FLEXURAL MODULUS (GN/m ²) | FLEXURAL STRENGTH. (MN/m ²) |
|-------------------------------|----------------------|--|--|
| Ortho methyl phenol. | 25. | 3.5. | 26.0. |
| | 80. | 0.6. | 13.0. |
| | 145. | 0.35. | 10.0. |
| Meta methyl phenol. | 25. | 5.35. | 46.0. |
| | 80. | 1.55. | 16.0. |
| | 145. | 0.35. | 8.5. |
| m/p-iso- propyl phenol. | 25. | 11.8. | 129. |
| | 80. | 6.0. | 68.5. |
| | 145. | 4.2. | 43.5. |

-O-O-O-O-O-O-O-O-

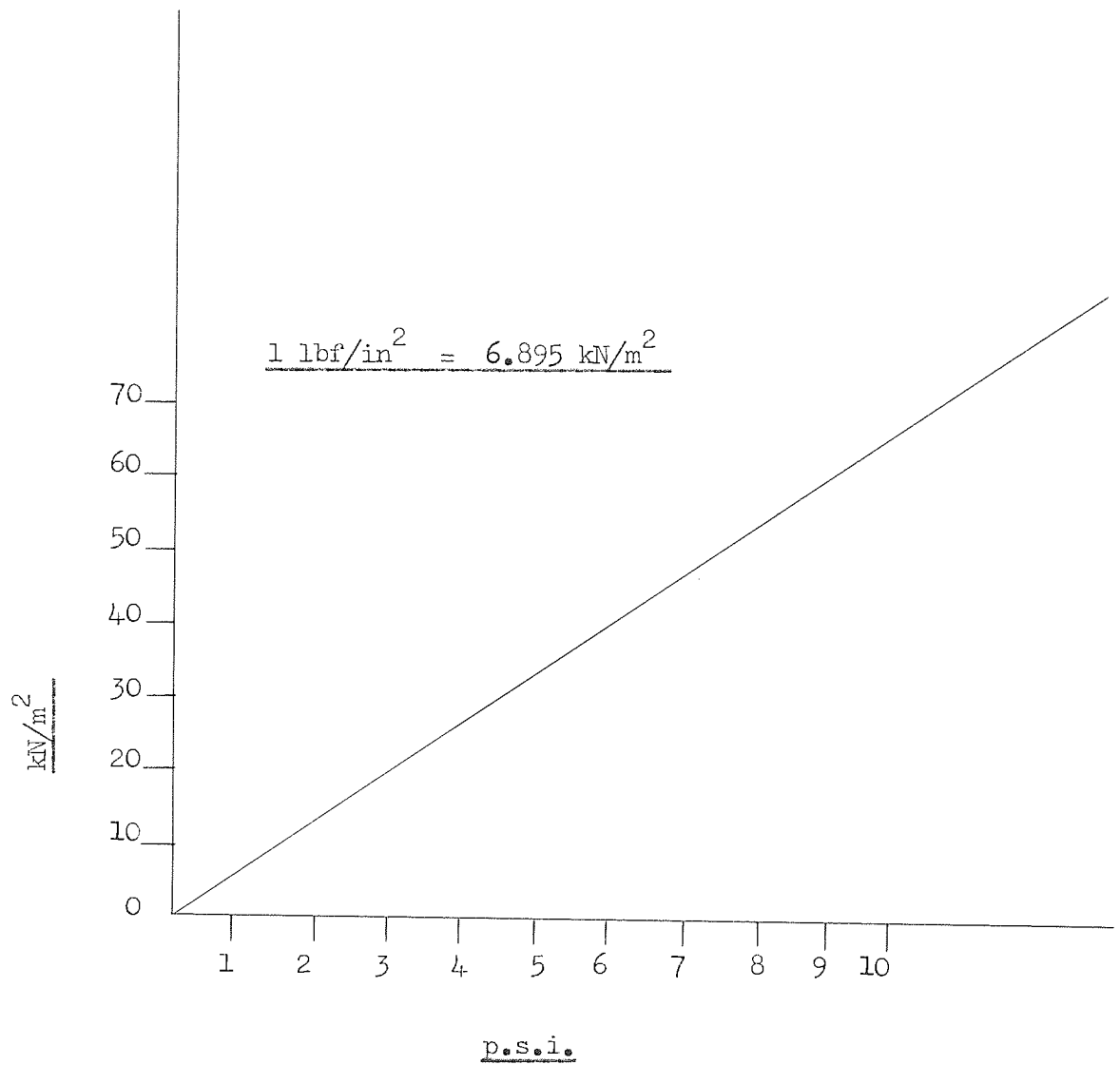

FIGURE 59. CONVERSION CHART. - p.s.i. to N/m².

APPENDIX 4.TORSIONAL PENDULUM.CALCULATION OF MOMENT OF INERTIA.

The moments of inertia of the two equal weights placed at equal distances from the centre of the beam were calculated from the standard equation:-

$$I = 2m \left(l^2 + \frac{b^2}{12} + \frac{d^2}{16} \right)$$

where m = the mass of the individual weight = 981 gm.
 d = diameter of the weight = 7.2 cm.
 b = width of the weight = 3.35 cm.
 l = distance from the centre of the beam to the centre of the weight.

Four values were possible for l;

l (i) 8.5 cm.

l (ii) 11.0 cm.

l (iii) 16.2 cm.

l (iv) 23.0 cm.

To calculate the moments of inertia of the complete system, the moment of inertia (I_0) of the beam and suspension wire must be known. This was obtained by using a steel specimen, which was assumed to be ideally elastic and hence independent of the frequency of oscillation. Hence, I_0 can be found from,

$$I_0 = \frac{v_i^2 I_i^2}{v_0^2 v_i^2} = \frac{v_{ii}^2 I_{ii}^2}{v_0^2 - v_{ii}^2} = \frac{v_{iii}^2 I_{iii}^2}{v_0^2 - v_{iii}^2} = \frac{v_{iv}^2 I_{iv}^2}{v_0^2 - v_{iv}^2}$$

where I_0 = moment of inertia of the beam and suspension wire only.
 v_i, v_{ii}, v_{iii} = frequencies of oscillation (hz) of the system when the weights are at distances l_i, l_{ii} and l_{iii} .

and

I_i, I_{ii}, I_{iii} = moments of inertia of the weight at distances

l_i, l_{ii} and l_{iii} .

Hence, knowing I_o , it is possible to find the moments of inertia of the complete system.

$$I_o = 29/\mu_{Nm}^2.$$

$$I_1 = I_o + I(i) = 177/\mu_{Nm}^2.$$

$$I_2 = I_o + I(ii) = 255/\mu_{Nm}^2.$$

$$I_3 = I_o + I(iii) = 551/\mu_{Nm}^2.$$

$$I_4 = I_o + I(iv) = 1074/\mu_{Nm}^2.$$

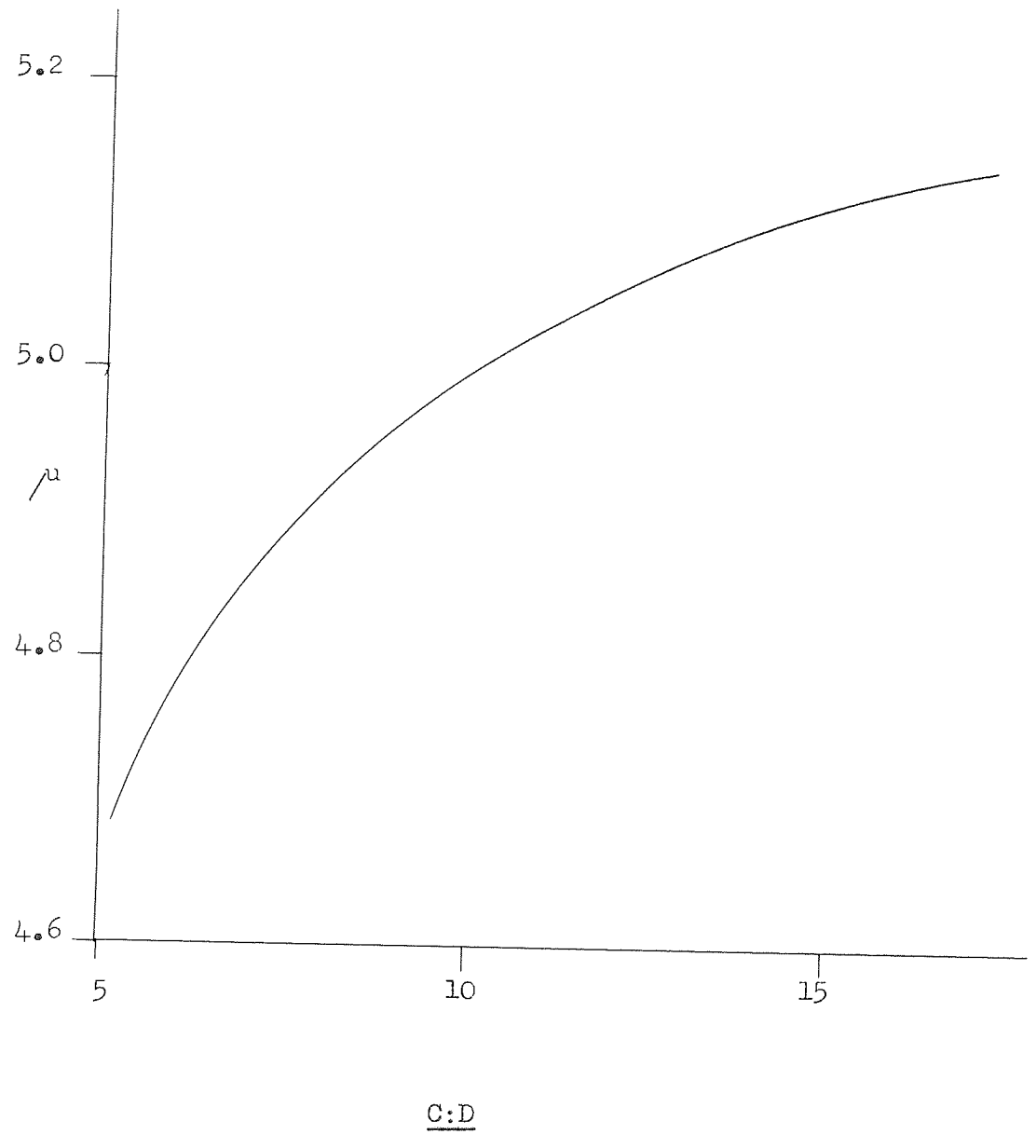

FIGURE 60. SHAPE FACTOR (λ) AS A FUNCTION OF WIDTH:DEPTH (C:D) RATIO (TAKEN FROM NIELSEN⁽²¹⁾).

APPENDIX 5.ITEMS OF EQUIPMENT USED IN THE EXPERIMENTAL WORK.POWER PRESS.

Hordern, Mason & Edwards Limited. Type L.M.6.

PUNCH AND DIE.

N. B. Drew & Sons, Aston, Birmingham, made to
University of Aston specification.

TENSILE TEST MACHINE.

Tensometer Limited. Croydon. Type E.

IMPREGNATOR.

N. B. Drew & Sons, Aston, Birmingham, made to
University of Aston specification.

OVEN.

Laboratory Thermal Equipment Limited. Type F.

HYDRAULIC PRESSES.

- (1) Apex Construction Limited. Type 341-2.
10 tons. (used for flash test).
- (2) T. H. & J. Daniels Limited. Mk.2.
100 ton downstroke (used for pressing
laminates).

"NONIUS" TORSIONAL PENDULUM.

N. V. Verenigde Instrumentenfabrieken, Delft, Holland.

REFERENCES.

1. Watson, K.L., Ph.D. thesis, University of Aston, (Sept:1969).
2. Learmonth, G.S., Watson, K.L., *Plastics & Polymers*, 36, (Feb: 1968), 45.
3. Learmonth, G.S., Watson, K.L., *Plastics & Polymers*, 36, (June, 1968), 213.
4. Hojo, H., *Rev. elect. commun Lab.*, Tokyo, 13, (July-Aug:1965), 471.
5. German Standard D.I.N., 53, 488, (Sept: 1963).
6. A.S.T.M. Standard method, D.617-44.
7. B.S., 2076:1954.
8. B.S., 1137:1966.
9. Stel, M., Jacobs, F.M., and Shriek, D., *Kunststoffe*, 42, (Nov: 1952), 93.
10. Radovsky, D.A., Kendall, F.T., and McHerron, L.A., *Insulation*, Lake Forest, 8 (Sept: 1962), 57.
11. Radovsky, D.A., *Proc. 6th Electrical Insulation Conf.* (New York, Sept: 1965), page 28.
12. Vincent, P.I., *Plastics*, 26, (Oct: 1961), 121.
13. Heap, R.D., Norman, R.H., "Flexural testing of Plastics", *Plastics Institute*, (1969).
14. Mullin, J.V., Knoell, A.C., 25th Annual Tech. Conf, (1970), *Reinf/Compos Div, S.P.i.*
15. Nielsen, L.E., *S.P.E. Journal*, (May, 1960), 525.
16. Nielsen, L.E., *A.S.T.M. Bull*, 48, (1950), 165.
17. Nederveen, C.J., Van der Wal, C.W., *Rheol Acta*, 6, pt 4, (1967), 316.

18. Drum, M.F., Dodge, C.W., Nielsen, L.E., *Ind & Eng Chem* 48, No.1, (Jan: 1956), 76.
19. Karas, G.C., Warburton, B, *Brit.Plast*, (March, 1961), 131.
20. Manual for "Nonius" torsional pendulum.
21. Nielsen, L.E., "Mechanical properties of polymers", Reinhold Publ.Corp, New York, (1962), 194.
22. Garland and Manza, *Materie Plastiche*, 28, (1962), 388.
23. Baekeland, L.H., *J.Ind. Eng. Chem*, 1, (1909), 149.
24. Royals, E.E., "Advanced Organic Chemistry", Prentice-Hall, Englewood Cliffs, N.J., (1954).
25. Francis, D.J., Yeddanapalli, L.M., *Die Makromol Chem*, 125, (1969), 119.
26. Martin, A.E., *Nature*, 166, (1950), 474.
27. Carswell, T.S., "Phenoplasts", *High polymers*, Vol.7, Interscience Publishers Inc., (1947), page 40.
28. Houwink, R., *Trans Faraday Soc.*, 32, (1936), 122.
29. Idem, *ibid*, 32, (1936), 131.
30. Megson, N.H.L., Wood, W.A., *Nature*, 140, (1937), 642.
31. Freeman, J.H., *Anal Chem.*, 24, (1952), 955.
32. Zulaicia, J., Guiochon, G., *J. Poly. Sci.*, Part 13, 14, (1966), 567.
33. Igonin, L.A., Mirakhmedor, M.M., Tuchaninova, K.L., Shabadash, A.N., *Doklady Akad Nauk, S.S.S.R.*, 141, (1961), 1366.
34. Kormarova, L.I., Korshak, V.V., Sergeev, V.A., Koslov, L.V., Lokshin, B.V., *Zh Prikl Spektrosk*, 6, (4), (1967), 501.
35. Bender, N.L., *Ind. Eng. Chem.*, 44, (1952), 1619.
36. Cairns, T, Eglinton, G, *Nature*, London, 196, (Nov: 1962), 535.

37. Culbertson, H.M., Higginbottom, H.P., J.Poly. Sci. Part A, 3, (1965), 1079.
38. Learmonth, G.S., Marriot, A.G., European. Poly. J., 5, (1969), 441.
39. Learmonth, G. S., Nabi, L.G., Bramham, G., Bailey, J., Plastics & Polymers, (June, 1969), 201.
40. Learmonth, G. S., Osborn, P., J. App. Poly. Sci., 12, (1968), 1315.
41. Hultsch, K., Chemie der Phenolharze, Springer-Verlag, Berlin, 1950.
42. Wohl, A., Mylo, B., Ber, 45, (1912), 2046.
43. Pritchett, E.G.K., Chem and In., (May, 1949), 295.
44. Redfern, C.A., Brit. Plast, 13, (1942), 481.
45. Baekeland, L.H., Bender, H.L. Ind. Eng. Chem, 17, (1952), 225.
46. Herman, F.J., Chem Abs, 41, (1947), 7811.
47. Freeman, J.H. Traynor, E.J., S.P.E., 17, (1961), 673.
48. Hilditch, T.P., Smith, C.J., J.S.C.I., London, 54, (1935) 111T.
49. Hultsch, K., J. Prakt. Chem., 158, (1941), 275.
50. Greth, A., Kunststoffe, 31, (1941), 345.
51. Merjan, A., Shaulders, B.A., Gardner, P.D., J.Org. Chem., 28, (1963), 2148.
52. Cook, C.D., J. Org. Chem., 18, (1953), 261.
53. Whitehouse, A.A.K., Pritchett, E.G.K., and Barnett, G., "Phenolic Resins", Plastics Institute Monograph, Iliffe Books Ltd., (1967).

54. Lilley, H.S., J.S.C.I., 67, (1948), 196.
55. Megson, N.J.L., "Phenolic Resin Chemistry", Butterworths Scientific Publications, (1958), Ch.6.
56. Hunter, R.F., Chem. & Ind., (March, 1954), 263.
57. Niederl, J.B., Ruderman, I.W., J.A.C.S., (April, 1945), 1171.
58. Menzies, A.W., Wright, J.A.C.S., 43, (1921), 2314.
59. Burke, W.J., Ruetman, S.H., Higginbottom, H.P., J.Poly. Sci., 38, (1959), 513.
60. Burke, W.J., Craven, W.E., Rosenthal, A., Ruetman, S.H., Stephens, C.W., Weatherbee, C., J. Poly. Sci., 20, (1956), 75.
61. Kammerer, H., Kunststoffe, 56, No.3., (March, 1966), 154.
62. Doroshenko, Yu.E., Korshak, V.V., Sergeev, V.A., Sov. Plast., (August, 1966), 13.
63. Freeman, J.H., J.A.C.S., 74, (1952), 6257.
64. Martin, R.W., Anal. Chem., 23, (1951), 883.
65. Stenmark, G.A., Weiss, F.T., Anal. Chem., 28, (1956), 260.
66. Carpenter, A.T., Hunter, R.F., J.app. Chem., (1951), 217.
67. Phillips, L.N., Trans.Plast. Inst., 32, (1964), 298.
68. Phillips, L.N., Nixon, B., Colmington, J.A., R.A.E. Tech. Note, 65220, (Oct., 1965).
69. Friedel, C., Crafts, J.M., Compt. Rend., 84, (1877), 1392.
70. Olah, G.A., "Friedel Crafts and related reactions", Interscience Publishers, New York., (1963).
71. Brown, H.C., Grayson, M.J., J.A.C.S., 75, (1953), 6285.
72. Dow Chemical Co., U.S. Pat. 2,911, 380.

73. Monsanto Chemical Co., Brit. Pat., 1,034, 752.
74. Paxton, J.C., M.Sc. thesis, University of Aston in Birmingham, (July, 1970).
75. Garbett, P., B.Sc. thesis, University of Aston in Birmingham, (1970).
76. Harris, G.I., Br. Poly. J., 2, (Nov., 1970), 270.
77. Hercules Incorporated, Bulletin, A.C.M.-8.
78. Nederveen, C.J.N., Vander Wal, C.W., Rheol. Acta., 6, Pt.4., (1967), 316.
79. Geissmann, T.A., Clinton, R.O., J.A.C.S., 68, (1946) 697.
80. Kleiderer, E.C., Kormfield, E.C., J. Org Chem, 13, (1948), 455.
81. Martin, R.W., "The Chemistry of Phenolic Resins" John Wiley and Sons Inc., (1956).
82. Freeman, J.H., Sprengling, G.R., J.A.C.S., 72, (1950), 1982.
83. Keeling, R.J., I.E.E.E., Trans. Electrical Insulation, E.I. - 3 (May, 1968), 55.
84. Ravve. A., "Organic Chemistry of Macromolecules", Edward Arnold (Publishers) Ltd., London, 1967, Chap. 17.
85. Pummerer, R., Schmidutz, G., Seifert, H., Ber, 85, (1952), 535.
86. Von Euler, H., de Kispeczy, S., Z. Physik. Chem., 189, (1941), 109.
87. Watson, K.L., Private Communication (1971).
88. Megson, N.J.L., J.S.C.I., (1949), 295.