

Observation of 550 MHz passively harmonic mode-locked pulses at L-band in an Er-doped fiber laser using carbon nanotubes film*

Qianqian Huang(黄千千)¹, Chuanhang Zou(邹传杭)¹, Tianxing Wang(王天行)^{1,5},
Mohammed Al Araimi^{2,3,4}, Aleksey Rozhin^{2,3}, and Chengbo Mou(牟成博)^{1†}

¹*Key Laboratory of Specialty Fiber Optics and Optical Access Networks, Shanghai Institute for Advanced Communication and Data Science, Joint International Research Laboratory of Specialty Fiber Optics and Advanced Communication, Shanghai University, Shanghai 200444, P. R. China*

²*Aston Institute of Photonic Technologies (AIPT), Aston University, Birmingham, B4 7ET, United Kingdom*

³*Nanoscience Research Group, Aston University, Birmingham, B4 7ET, United Kingdom*

⁴*Al Musanna College of Technology, Muladdah, Al Musanna, P.O.Box 191, P.C.314, Sultanate of Oman*

⁵*Key Laboratory of Materials for High Power Laser, Shanghai Institute of Optics and Fine Mechanics, Chinese Academy of Sciences, Shanghai 201800, China*

We demonstrate a passively harmonic mode-locked (PHML) fiber laser operating at L-band using carbon nanotubes polyvinyl alcohol (CNTs-PVA) film. Under suitable pump power and appropriate setting of polarization controller (PC), the 54th harmonic pulses at L-band are generated with the side mode suppression ratio (SMSR) better than 44dB, and repetition frequency of 503.37 MHz. Further increasing pump power leads to higher frequency of 550 MHz with compromised stability of 38.5 dB SMSR. To the best of our knowledge, this is the first demonstration on the generation of L-band PHML pulses from an Er-doped fiber laser based on CNTs.

Keywords: passively harmonic mode locking, L-band, Er-doped fiber laser, carbon nanotubes film

PACS: 42.60.Fc, 42.65.Re, 42.70.-a

1. Introduction

With the widespread application of optical communication system, the conventional C-band (1530-1565 nm) is unable to meet the ever-increasing requirements for transmission capacity. To alleviate this problem, L-band (1565-1625 nm) as an extended wavelength range has been proven to be able to enlarge the optical communication capacity, where the silica fibers also feature low loss.^[1] Moreover, it is

* Project supported by National Natural Science Foundation of China (61605107); Young Eastern Scholar Program at Shanghai Institutions of Higher Learning (QD2015027); the “Young 1000 Talent Plan” Program of China; The open program (Grant No.2017GZKF17) of the State Key Laboratory of Advanced Optical Communication Systems and Networks at Shanghai Jiaotong University, China; RAEng/The Leverhulme Trust Senior Research Fellowships (LTSRF1617/13/57).

† Corresponding author. E-mail: moucl@shu.edu.cn

worth noting that some potential applications such as high speed optical sampling, frequency comb generation and optical communication are in high demand for repetition rate.^[2-4] In consequence, exploring mode locked fiber laser which combines two features of L-band operation and high repetition rate is of great importance.

In general, mode locked operation can be realized either actively or passively. Compared to active mode locking, passive mode locking is more desirable since it offers great merits of compactness, simplicity, stability and better pulses quality.^[5] Nowadays, various technologies have emerged to realize passive mode locking, for instance, semiconductor saturable absorber mirror (SESAM),^[6] nonlinear polarization rotation (NPR),^[7] CNTs^[8] and some other novel materials.^[9, 10] Especially, CNTs are identified as effective mode lockers since they exhibit distinct merits of ultra-short recovery time, easy fabrication, and wide operation wavelength range.^[11] Previous studies have been successfully conducted at L-band from fiber lasers based on CNTs. Sun *et al* reported an L-band fiber laser firstly by using a CNTs-PVA saturable absorber(SA) with a broad absorption at 1.6 μm .^[12] In 2013, a passively mode-locked L band fiber laser using a 180 cm highly doped bismuth–erbium-codoped fiber as gain medium was presented, with given pulse energy of 440 pJ and pulse duration of 460 fs.^[13] In order to achieve ultra-short pulses in this region, Kwon *et al* designed a stretched-pulse L-band laser generating 110 fs pulse with 70 dB signal-to-noise ratio (SNR).^[14] However, all of the reports do not concentrate on the repetition rate of the lasers, where the frequency limits at tens of Megahertz. Ordinarily, PHML is deemed as one of the most efficient methods to achieve high repetition rate, where the frequency of the laser can be multiplied when the pump power exceeds a certain value.^[15] Nevertheless, there is no report on the generation of PHML pulses operating at L-band from an Er-doped fiber laser using CNTs.

In general, there are two dominant types of CNTs SA namely CNTs film and evanescent-field interaction CNTs. Compared to evanescent-field interaction CNTs type, CNTs film possesses inherent advantages of easier fabrication procedure, higher flexibility and compactness, which can be integrated to the cavity just by inserted between two fiber connectors.^[16] Recently, we have demonstrated that CNTs film can serve as practical SA to realize high repetition rate in C band via HML.^[17] In this paper, we demonstrate a PHML fiber laser performing in the L-band region based on CNTs-PVA film. Under advisable pump power and polarization state, 503.37 MHz pulses with 44.7 dB SMSR centered at 1595.54 nm are obtained, which corresponds to 54th harmonic order. It should be emphasized that the level of SMSR unveils the excellent stability of our laser. When pump power increases up to 212.8 mW, 550 MHz pulses with 38.5 dB SMSR are further achieved. To the best of knowledge, such high repetition rate pulses centered at L-band are firstly realized from a PHML Er-doped fiber laser using CNTs.

2. Characterization of CNTs-PVA film and experimental set up

Single wall carbon nanotube fabricated by **high-pressure CO (HiPCO)** method was used in the experiment. The detailed fabrication procedure of CNTs-PVA film is summarized in Ref. [18]. The resultant CNTs-PVA film are characterized by the absorption spectrum

as illustrated in Fig. 1(a). The broad absorption band ranges from 1000 nm to 1900 nm and the absorption strength is close to 0.16 at 1600 nm, which provides the possibility to achieve L-band operation. The measured Raman spectrum with an excitation wavelength of 532 nm is shown in Fig. 1(b), from which we can see that the CNTs-PVA film is single walled due to the presence of the radial breathing mode (RBM) and G mode (1588 cm^{-1}). Clearly, the weak D mode manifests few defects of the sample. Moreover, the RBM is equal to 250 cm^{-1} and the calculated mean tube diameter is $\sim 0.88\text{ nm}$. The measured nonlinear transmission is depicted in Fig. 1(c) giving modulation depth of 6.2 %, which provides a solid evidence that the CNTs-PVA film can be considered as an effective SA to implement mode locking.

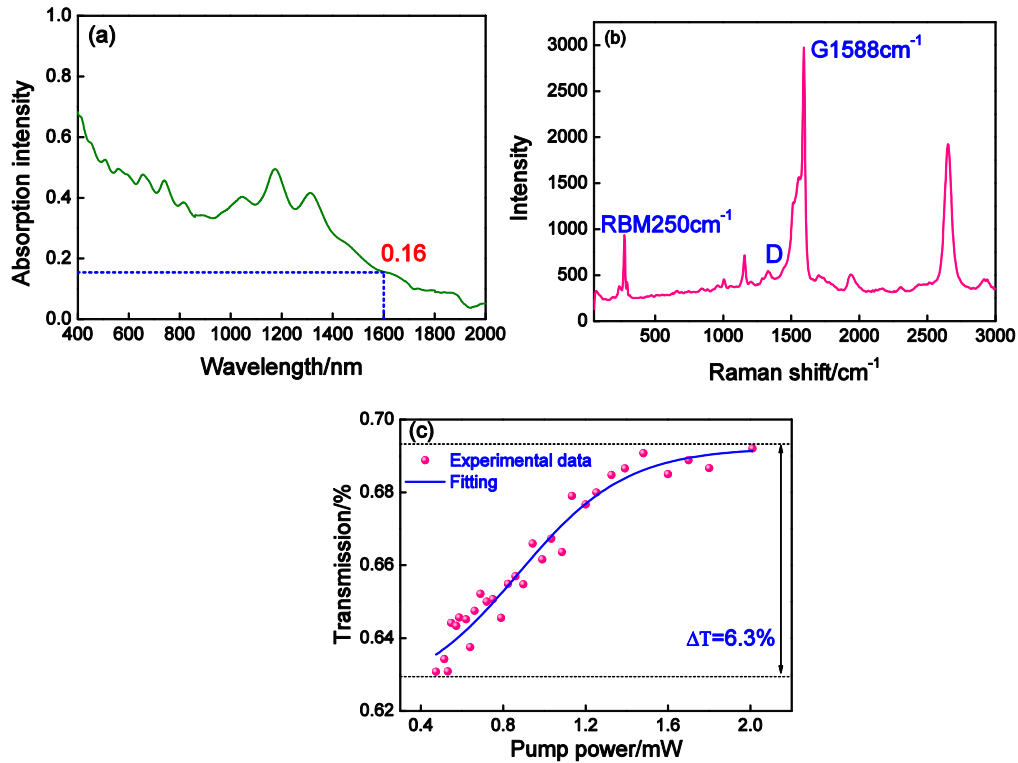

Fig.1. (color online) The characteristics of CNTs-PVA film: (a) the linear absorption spectrum, (b) the measured Raman spectrum, and (c) the nonlinear transmission

The experimental configuration of the proposed PHML fiber laser based on CNTs-PVA film is illustrated schematically in Fig. 2. The pump light from a benchtop laser (OV LINK, Wuhan, China) at 980 nm is launched into the ring cavity through a wavelength-division multiplexer (WDM) made of OFS 980 fiber. A section of 8.18 m Erbium-doped fiber (EDF Er30-4/125 from Liekki) with the peak absorption of 30 dB/m and a dispersion of $+14.45\text{ ps}^2/\text{km}$ at 1590 nm is adopted as gain medium to enable L-band lasing. The length of EDF is much shorter than that used in Ref. [19] taking advantages of the high concentration of the EDF. Also, it is noteworthy that the mode field diameter at 1550 nm is $6.5 \pm 0.5\text{ }\mu\text{m}$, which is capable to introduce high nonlinearity into the cavity. A polarization-independent isolator (PI-ISO) is utilized to transmit the light in a clockwise direction. 10 % beam is coupled out via an output coupler (OC) for detection. The optimization of polarization state in cavity is realized by a PC. A piece of $2 \times 2\text{ mm}$ CNTs-PVA film embedded between two standard fiber

ferrules directly is employed as a SA in conjunction with 90 % port of OC. The rest of cavity is organized by 2.6 m OFS 980 and 11.42 m single mode fiber (SMF). The group velocity dispersion (GVD) coefficients are $+4.5 \text{ ps}^2/\text{km}$ and $-22.8 \text{ ps}^2/\text{km}$, respectively. The total length is 22.35 m and the overall dispersion is -0.13 ps^2 which results in a soliton operation.

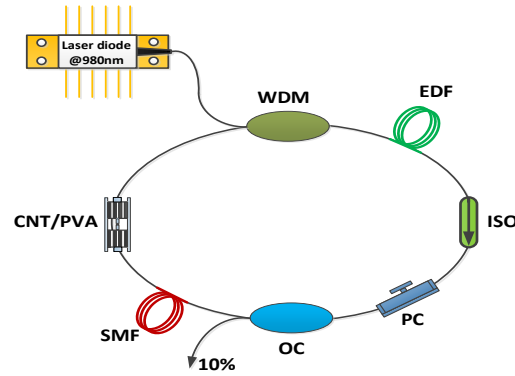

Fig.2. (color online) Experimental scheme of the PHML fiber laser based on CNTs-PVA film

The pulse signals can be visualized on an 8 GHz oscilloscope (OSC, KEYSIGHT DSO90804A) together with a 12.5 GHz photo-detector (PD, Newport 818- BB-51F). The radio frequency spectrum is recorded by a radio frequency (RF) spectrum analyzer (SIGLENT, SSA 3032X). The pulse spectrum is characterized by an optical spectrum analyzer (OSA, Yokogawa AQ6370C). Also, an autocorrelator (FEMTOCHROME, FR-103WS) is utilized to measure the pulse duration.

3. Experimental results and discussion

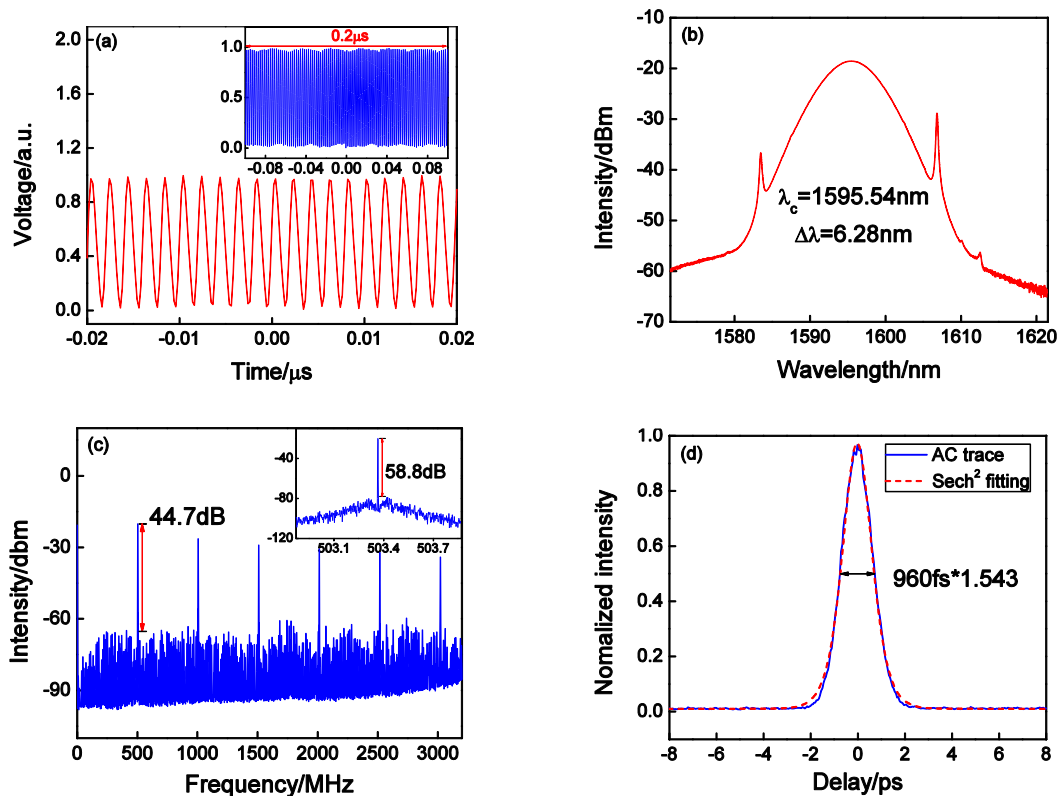
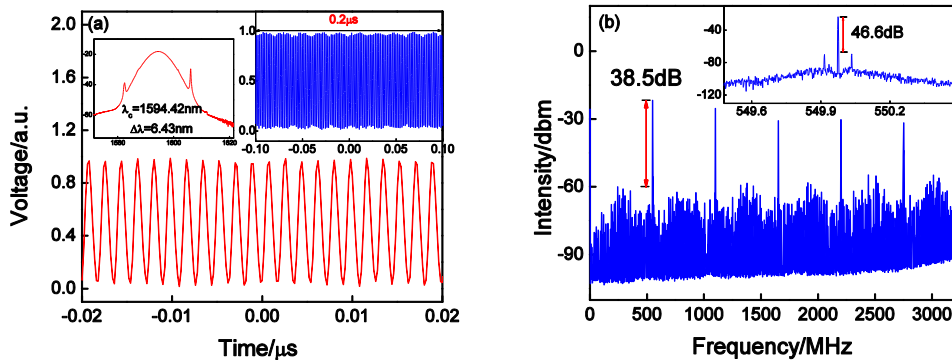

Fig.3. (color online) The performances of the pulses under 202 mW: (a) pulse train at the 54th harmonic (inset: pulse train with the span of 0.2 μ s), (b) optical spectrum centered at 1595.54 nm, (c) RF spectra with 3.2 GHz span and 10kHz resolution bandwidth(RBW) (inset: RF spectrum within the range of 1 MHz), and (d) the measured autocorrelation trace.

The mode-locked behavior occurs when pump laser delivers up to 80 mW. However, the stable single pulse operation is hard to realize no matter how to adjust the polarization state under the weak pump power. We conjecture that the phenomenon comes from the highly nonlinear effect introduced from the longer EDF which features high doping concentration and relatively smaller mode field diameter as mentioned before. When pump power reaches 92 mW, the 11st HML is implemented eventually with the proper setting of PC. Further increasing of pump power will lead to higher harmonic order. When the pump power is set to 202 mW, the laser operates at the harmonics of 54th with 5.35 mW output power, corresponding to 503.37 MHz repetition rate as shown in Fig 3. We can see from Fig. 3(a) that the pulses are spaced equally by 1.99 ns interval with similar amplitude. The optical spectrum centers at 1595.54 nm, with 6.28 nm 3dB bandwidth as presented in Fig. 3(b). In general, the emitting wavelength of pulses is regulated by the length of active fiber and the loss of the cavity.^[20] Therefore, it is considered that the longer length of the highly doped EDF compared with some conventional C-band lasers^{[17][21-22]} contributes to in-band absorption which leads to L-band emission.^[23] In addition, the existence of Kelly band makes a clear indication of soliton generation. The recorded RF spectra are depicted in Fig. 3(c) with the span of 3.2 GHz and RBW of 1 kHz. It is apparent that the frequency of the first pronounce peak is 503.37 MHz which can be taken as a further evidence of 503.37 MHz repetition rate. Remarkably, the SMSR is 44.7 dB while the SNR is 58.8 dB shown in the inset of Fig. 3(c), which exhibits improvement over previous PHML operation at C-band^[21-22], manifesting stable operation. The corresponding pulse duration is 960 fs since the pulses possess secant hyperbolic profile illustrated in Fig. 3(d). Therefore, the time bandwidth product (TBP) is 0.71, which is higher than 0.315 due to the presence of slight pulse chirp.



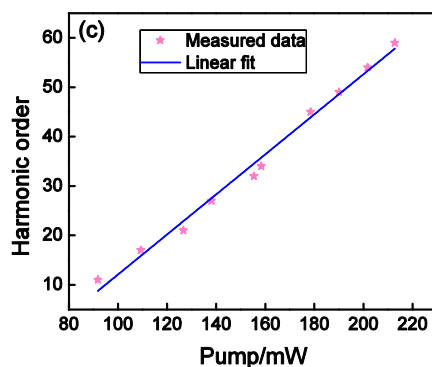

Fig.4. (color online) (a) the observed pulse train of 550 MHz pulses (insert: the left one is optical spectrum, the right one is the pulse train spanning 0.2 μ s), (b) measured RF spectra at 550 MHz (insert: RF spectrum centered in 550 MHz), and (c) harmonic order versus the given pump power.

Additionally, the repetition rate can scale up to 550 MHz at 59th harmonic under 213 mW pump power. From Fig. 4(a), we can see that the pulse train is still ordered aligned and exhibits equal spacing while the spectrum is almost all the same as that in Fig. 3(b). Nevertheless, the pulse train shows relatively small value of 38.5 dB SMSR, which still manifests good stability. As described so far, 11st to 59th harmonic order is found with a consequence of pump power increase. The relationship between the two factors is plotted in Fig. 4(c) showing almost linear slope. Furthermore, it is noted that the value of SMSR keeps higher than 44dB, when the harmonic order ranges from 11 to 54, which is much higher than Ref. [17], showing superb stability. And the pulses are capable of stable operation for several hours once HML occurs. Also, it is worth to emphasize that our laser always works in L-band region regardless of the harmonic order. Nevertheless, the Q-switched operation appears as the pump power further increases. As a consequence, the pulse energy becomes high enough immediately to damage the CNTs-PVA film-based SA. Enlightened by the experimental results reported in Ref. [24-25], it is expected to further expand the frequency by optimizing the cavity dispersion and nonlinearity.

4. Conclusion

In conclusion, a PHML fiber laser operating at L-band based on CNTs-PVA film is experimentally demonstrated. The 54th harmonic pulses at a repetition rate of 503.74 MHz centered at 1595.54 nm with 44.7 dB SMSR are obtained under appropriate polarization status and suitable pump power. And the highest recorded repetition rate in our laser is 550 MHz with compromised stability when pump power increases to 213 mW. To the best of our knowledge, it is the first report about the achievement of HML operation at L-band in an Er-doped fiber laser using CNTs. The noteworthy stability of the laser is demonstrated by the high level of SMSR. The laser we proposed here features favorable performances for some applications such as L-band optical communication systems, spectroscopy, *etc.*

References

1. Srivastava A, Radic S, Wolf C, Centanni J, Sulhoff J, Kantor K, and Sun Y [2000 IEEE Photonics Technol. Lett. 12 1570](#)

2. Haus H A and Wong W S [1996 Rev. Mod. Phys. 68 423](#)
3. Jones R J and Diels J-C [2001 Phys. Rev. Lett. 86 3288](#)
4. Schlager J B, Hale P D, and Franzen D L [1993 Microwave Opt. Technol. Lett. 6 835](#)
5. Tamura K, Ippen E P, Haus H A, and Nelson L E [1993 Opt. Lett. 18 1080](#)
6. Luo Z-C, Luo A-P, and Xu W-C [2011 IEEE Photonics J. 3 64](#)
7. Mou C, Wang H, Bale B G, Zhou K, Zhang L, and Bennion I [2010 Opt. Express 18 18906](#)
8. Rozhin A G, Sakakibara Y, Namiki S, Tokumoto M, Kataura H, and Achiba Y [2006 Appl. Phys. Lett. 88 051118](#)
9. Liu M, Zheng X-W, Qi Y-L, Liu H, Luo A-P, Luo Z-C, Xu W-C, Zhao C-J, and Zhang H [2014 Opt. Express 22 22841](#)
10. Popa D, Sun Z, Torrisi F, Hasan T, Wang F, and Ferrari A [2010 Appl. Phys. Lett. 97 203106](#)
11. Popa D, Sun Z, Hasan T, Cho W, Wang F, Torrisi F, and Ferrari A [2012 Appl. Phys. Lett. 101 153107](#)
12. Sun Z, Rozhin A, Wang F, Scardaci V, Milne W, White I, Henrich F, and Ferrari A [2008 Appl. Phys. Lett. 93 061114](#)
13. Ahmad H, Zulkifli A, Muhammad F, Zulkifli M, Thambiratnam K, and Harun S [2014 Appl. Phys. B 115 407](#)
14. Kwon W S, Lee H, Kim J H, Choi J, Kim K-S, and Kim S [2015 Opt. Express 23 7779](#)
15. Lecaplain C and Grelu P [2013 Opt. Express 21 10897](#)
16. Zou C, Wang T, Yan Z, Huang Q, AlAraimi M, Rozhin A, and Mou C [2018 Opt. Commun. 406 151](#)
17. Huang Q, Wang T, Zou C, AlAraimi M, Rozhin A, and Mou C [2018 Chin. Opt. Lett. 16 030019](#)
18. Mou C, Sergeev S, Rozhin A, and Turistyn S [2011 Opt. Lett. 36 3831](#)
19. Yan D, Li X, Zhang S, Han M, Han H, and Yang Z [2016 Opt. Express 24 739](#)
20. Franco P, Midrio M, Tozzato A, Romagnoli M, and Fontana F [1994 J. Opt. Soc. Am. B 11 1090](#)
21. Mou C, Arif R, Rozhin A, and Turitsyn S [2012 Opt. Mater. Express 2 884](#)
22. Jiang K, Fu S, Shum P, and Lin C [2010 IEEE Photonics Technol. Lett. 22 754](#)
23. Luo J L, Li L, Ge Y Q, and Jin X X [2014 IEEE Photonics Technol. Lett. 26 2438](#)
24. Jun C S, Choi S Y, Rotermund F, Kim B Y, and Yeom D-I [2012 Opt. Lett. 37 1862](#)
25. Tao S, Xu L, Chen G, Gu C, and Song H [2016 J. Lightwave Technol. 34 2354](#)